

Altivar 61

Variable speed drives for
synchronous motors and
asynchronous motors

Installation Manual

12/2009



0.37 kW (0.5 HP) ... 45 kW (60 HP) / 200 - 240 V
0.75 kW (1 HP) ... 75 kW (100 HP) / 380 - 480 V
2.2 kW (3 HP) ... 7.5 kW (10 HP) / 500 - 600 V
2.2 kW (3 HP) ... 90 kW (100 HP) / 500 - 690 V

Contents

Important information	4
Before you begin	5
Steps for setting up the drive	6
Preliminary recommendations	7
Drive ratings	9
Dimensions and weights	12
Mounting and temperature conditions	13
Mounting in a wall-mounted or floor-standing enclosure	16
Installing the graphic display terminal	18
Position of the charging LED	19
Installing option cards	20
Installing the EMC plates	22
Wiring precautions	23
Power terminals	25
Control terminals	27
Option terminals	29
Connection diagrams	34
Use on IT system and "corner grounded" system	43
Electromagnetic compatibility, wiring	45

Important information

PLEASE NOTE

Please read these instructions carefully and examine the equipment in order to familiarize yourself with the device before installing, operating or carrying out any maintenance work on it.

The following special messages that you will come across in this document or on the device are designed to warn you about potential risks or draw your attention to information that will clarify or simplify a procedure.



The addition of this symbol to a "Danger" or "Warning" safety label indicates that there is an electrical risk that will result in injury if the instructions are not followed.



This is a safety warning symbol. It warns you of the potential risk of injury. You must comply with all safety messages that follow this symbol in order to avoid the risk of injury or death.

DANGER

DANGER indicates an imminently hazardous situation which, if not avoided, **will result in** death, serious injury or equipment damage.

WARNING

WARNING indicates a potentially hazardous situation which, if not avoided, **can result in** death, serious injury or equipment damage.

CAUTION

CAUTION indicates a potentially hazardous situation which, if not avoided, **can result in** injury or equipment damage.

PLEASE NOTE:

Only qualified personnel are authorized to carry out maintenance work on electrical equipment. Schneider Electric accepts no responsibility for the consequences of using this device. This document does not constitute an instruction manual for inexperienced personnel.
© 2006 Schneider Electric. All rights reserved.

Before you begin

Read and observe these instructions before performing any procedure on this drive.

DANGER

RISK OF ELECTRIC SHOCK

- Read and understand this manual before installing or operating the Altivar 61 drive. Installation, adjustment, repair, and maintenance must be performed by qualified personnel.
- The user is responsible for compliance with all international and national electrical standards in force concerning protective grounding of all equipment.
- Many parts in this variable speed drive, including printed wiring boards, operate at line voltage. **DO NOT TOUCH.**
Use only electrically insulated tools.
- **DO NOT** touch unshielded components or terminal strip screw connections with voltage present.
- **DO NOT** short across terminals PA/+ and PC/- or across the DC bus capacitors.
- Install and close all the covers before applying power or starting and stopping the drive.
- Before servicing the variable speed drive
 - Disconnect all power.
 - Place a “DO NOT TURN ON” label on the variable speed drive disconnect.
 - Lock the disconnect in the open position.
- Disconnect all power including external control power that may be present before servicing the drive. **WAIT 15 MINUTES** to allow the DC bus capacitors to discharge. Then follow the DC bus voltage measurement procedure on page [19](#) to verify that the DC voltage is less than 45 V. The drive LEDs are not accurate indicators of the absence of DC bus voltage.

Failure to follow these instructions will result in death or serious injury.

CAUTION

IMPROPER DRIVE OPERATION

- If the drive is not turned on for a long period, the performance of its electrolytic capacitors will be reduced.
- If it is stopped for a prolonged period, turn the drive on at least every two years for at least 5 hours to restore the performance of the capacitors, then check its operation. It is recommended that the drive is not connected directly to the line voltage. The voltage should be increased gradually using an adjustable AC source.

Failure to follow these instructions can result in injury and/or equipment damage.

INSTALLATION

■ 1 Receive and inspect the drive controller

- Check that the catalog number printed on the label is the same as that on the purchase order
- Remove the Altivar from its packaging and check that it has not been damaged in transit

■ 2 Check the line voltage

- Check that the line voltage is compatible with the voltage range of the drive (see pages [9](#) and [10](#))

■ 3 Mount the drive

- Mount the drive in accordance with the instructions in this document
- Install any internal and external options

■ 4 Wire the drive

- Connect the motor, ensuring that its connections correspond to the voltage
- Connect the line supply, after making sure that the power is off
- Connect the control
- Connect the speed reference

Steps 1 to 4 must be performed with the power off.



PROGRAMMING

- **5** Please refer to the Programming Manual

Preliminary recommendations

Handling/Storage

To protect the drive prior to installation, handle and store the device in its packaging. Ensure that the ambient conditions are acceptable.

WARNING

DAMAGED PACKAGING

If the packaging appears damaged, it can be dangerous to open it or handle it.
Take precautions against all risks when performing this operation.
Failure to follow this instruction can result in death or serious injury.

WARNING

DAMAGED EQUIPMENT

Do not operate or install any drive that appears damaged.
Failure to follow this instruction can result in death or serious injury.

Handling on installation

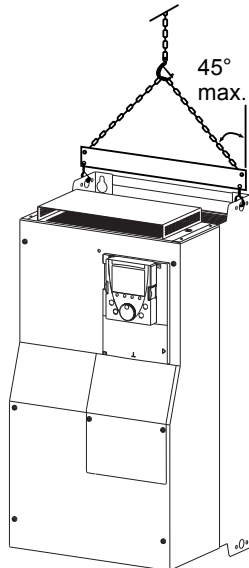

ALTIVAR 61 drives up to ratings ATV61HD15M3X, ATV61HD18N4 and ATV61HU75S6X can be removed from their packaging and installed without a handling device.

A hoist must be used for higher ratings and for ATV61H●●●Y drives; for this reason, these drives all have lifting lugs. Follow the recommendations on the next page.

Preliminary recommendations

Precautions

Read and observe the instructions in the Programming Manual.

CAUTION

INCOMPATIBLE LINE VOLTAGE

Before turning on and configuring the drive, ensure that the line voltage is compatible with the supply voltage range shown on the drive nameplate. The drive may be damaged if the line voltage is not compatible.

Failure to follow this instruction can result in injury and/or equipment damage.

DANGER

UNINTENDED EQUIPMENT OPERATION

- Before turning on and configuring the Altivar 61, check that the PWR (POWER REMOVAL) input is deactivated (at state 0) in order to prevent unintended operation.
- Before turning on the drive, or when exiting the configuration menus, check that the inputs assigned to the run command are deactivated (at state 0) since they can cause the motor to start immediately.

Failure to follow these instructions will result in death or serious injury.



If the safety of personnel requires the prohibition of unwanted or unintended operation, electronic locking is performed by the Altivar 61's Power Removal function.

This function requires the use of connection diagrams conforming to category 3 of standard EN 954-1 and safety integrity level 2 according to IEC/EN 61508.

The Power Removal function takes priority over any run command.

Drive ratings

Single-phase supply voltage: 200...240 V 50/60 Hz

Three-phase motor 200...240 V

Motor		Line supply (input)				Drive (output)		Altivar 61	
Power indicated on plate (1)		Max. line current (2)		Max. prospective line Isc	Apparent power	Max. inrush current (3)	Max. available nominal current In (1)	Max. transient current (1) for 60 s	Catalog number (4)(5)
kW	HP	at 200 V	at 240 V						
0.37	0.5	6.9	5.8	5	1.4	9.6	3	3.6	ATV61H075M3
0.75	1	12	9.9	5	2.4	9.6	4.8	5.7	ATV61HU15M3
1.5	2	18.2	15.7	5	3.7	9.6	8	9.6	ATV61HU22M3
2.2	3	25.9	22.1	5	5.3	9.6	11.0	13.2	ATV61HU30M3
3	-	25.9	22	5	5.3	9.6	13.7	16.4	ATV61HU40M3(6)
4	5	34.9	29.9	22	7	9.6	17.5	21	ATV61HU55M3(6)
5.5	7.5	47.3	40.1	22	9.5	23.4	27.5	33	ATV61HU75M3(6)

Three-phase supply voltage: 200...240 V 50/60 Hz

Three-phase motor 200...240 V

Motor		Line supply (input)				Drive (output)		Altivar 61	
Power indicated on plate (1)		Max. line current (2)		Max. prospective line Isc	Apparent power	Max. inrush current (3)	Max. available nominal current In (1)	Max. transient current (1) for 60 s	Catalog number (4)(5)
kW	HP	at 200 V	at 240 V						
0.75	1	6.1	5.3	5	2.2	9.6	4.8	5.7	ATV61H075M3
1.5	2	11.3	9.6	5	4	9.6	8	9.6	ATV61HU15M3
2.2	3	15	12.8	5	5.3	9.6	11	13.2	ATV61HU22M3
3	-	19.3	16.4	5	6.8	9.6	13.7	16.4	ATV61HU30M3
4	5	25.8	22.9	5	9.2	9.6	17.5	21	ATV61HU40M3
5.5	7.5	35	30.8	22	12.4	23.4	27.5	33	ATV61HU55M3
7.5	10	45	39.4	22	15.9	23.4	33	39.6	ATV61HU75M3
11	15	53.3	45.8	22	18.8	93.6	54	64.8	ATV61HD11M3X
15	20	71.7	61.6	22	25.1	93.6	66	79.2	ATV61HD15M3X
18.5	25	77	69	22	27.7	100	75	90	ATV61HD18M3X
22	30	88	80	22	32	100	88	105.6	ATV61HD22M3X
30	40	124	110	22	42.4	250	120	144	ATV61HD30M3X
37	50	141	127	22	51	250	144	173	ATV61HD37M3X
45	60	167	147	22	65	250	176	211	ATV61HD45M3X

(1) These power ratings and currents are given for an ambient temperature of 50°C (122°F) at the factory-set switching frequency, used in continuous operation (factory-set switching frequency of 4 kHz for ATV61H 075M3 to D15M3X and 2.5 kHz for ATV61H D18M3X to D45M3X).

Above this factory setting, the drive will reduce the switching frequency automatically in the event of excessive temperature rise.

For continuous operation above the factory setting, derating must be applied to the nominal drive current in accordance with the curves on page 14.

(2) Current on a line supply with the "Max. prospective line Isc" indicated and for a drive without any external options.

(3) Peak current on power-up for the max. voltage (240 V +10%).

(4) ATV61H 075M3 to D45M3X drives are available with or without a graphic display terminal. Catalog numbers for drives without a graphic display terminal have the letter Z added at the end, e.g.: ATV61H075M3Z. This option is not available for drives which operate in difficult environmental conditions (5).

(5) Drives with the S337 or 337 extension are designed for use in difficult environmental conditions (class 3C2 in accordance with IEC 721-3-3). They are supplied with a graphic display terminal.

(6) A line choke must be used (please refer to the catalog).



Inhibit the input phase loss fault (IPL) so that ATV61H 075M3 to U75M3 drives can operate on a single-phase supply (see the Programming Manual). If this fault is set to its factory configuration, the drive will stay locked in fault mode.

Drive ratings

Three-phase supply voltage: 380...480 V 50/60 Hz

Three-phase motor 380...480 V

Motor		Line supply (input)					Drive (output)			Altivar 61 Catalog number (4)(5)	
		Max. line current (2)		Max. prospective line I _{sc}	Apparent power	Max. inrush current (3)	Max. available nominal current I _n (1)		Max. transient current (1) for 60 s		
Power indicated on plate (1)	kW	HP	at 380 V				at 480 V	kA		kVA	A
				0.75	1	3.7	3	5	2.4	19.2	2.3
	1.5	2	5.8	5.3	5	4.1	19.2	4.1	3.4	4.9	ATV61HU15N4
	2.2	3	8.2	7.1	5	5.6	19.2	5.8	4.8	6.9	ATV61HU22N4
	3	-	10.7	9	5	7.2	19.2	7.8	6.2	9.3	ATV61HU30N4
	4	5	14.1	11.5	5	9.4	19.2	10.5	7.6	12.6	ATV61HU40N4
	5.5	7.5	20.3	17	22	13.7	46.7	14.3	11	17.1	ATV61HU55N4
	7.5	10	27	22.2	22	18.1	46.7	17.6	14	21.1	ATV61HU75N4
	11	15	36.6	30	22	24.5	93.4	27.7	21	33.2	ATV61HD11N4
	15	20	48	39	22	32	93.4	33	27	39.6	ATV61HD15N4
	18.5	25	45.5	37.5	22	30.5	93.4	41	34	49.2	ATV61HD18N4
	22	30	50	42	22	33	75	48	40	57.6	ATV61HD22N)
	30	40	66	56	22	44.7	90	66	52	79.2	ATV61HD30N4
	37	50	84	69	22	55.7	90	79	65	94.8	ATV61HD37N4
	45	60	104	85	22	62.7	200	94	77	112.8	ATV61HD45N4
	55	75	120	101	22	81.8	200	116	96	139	ATV61HD55N4
	75	100	167	137	22	110	200	160	124	192	ATV61HD75N4

(1) These power ratings and currents are given for an ambient temperature of 50°C (122°F) at the factory-set switching frequency, used in continuous operation (factory-set switching frequency of 4 kHz for ATV61H 075N4 to D30N4 drives, and 2.5 kHz for ATV61H D37N4 to D75N4).

Above this factory setting, the drive will reduce the switching frequency automatically in the event of excessive temperature rise. For continuous operation above the factory setting, derating must be applied to the nominal drive current in accordance with the curves on page 14.

(2) Current on a line supply with the "Max. prospective line I_{sc}" indicated and for a drive without any external options.

(3) Peak current on power-up for the max. voltage (480 V +10%).

(4) ATV61H 075N4 to D75N4 drives are available with or without a graphic display terminal. Catalog numbers for drives without a graphic display terminal have the letter Z added at the end, e.g.: ATV61H075N4Z. This option is not available for drives which operate in difficult environmental conditions (5).

(5) Drives with the S337 or 337 extension are designed for use in difficult environmental conditions (class 3C2 in accordance with IEC 721-3-3). They are supplied with a graphic display terminal.

Drive ratings

Three-phase supply voltage: 500...600 V 50/60 Hz

Three-phase motor 500...600 V

Motor		Line supply (input)			Drive (output)		Altivar 61	
Power indicated on plate (1)		Max. line current (2)			Max. prospective line I _{sc}	Max. available nominal current I _n (1)		Catalog number
500 V	575 V	at 500 V	at 600 V	500 V		575 V		
kW	HP	A	A	kA	A	A		
2.2	3	7.6	6.7	22	4.5	3.9	ATV61HU22S6X	
3	-	9.9	10	22	5.8	-	ATV61HU30S6X	
4	5	12.5	10.9	22	7.5	6.1	ATV61HU40S6X	
5.5	7.5	16.4	14.2	22	10	9	ATV61HU55S6X	
7.5	10	21.4	18.4	22	13.5	11	ATV61HU75S6X	

Three-phase supply voltage: 500...690 V 50/60 Hz

Three-phase motor 500...690 V

Motor			Line supply (input)			Drive (output)			Altivar 61	
Power indicated on plate (1)			Max. line current (2)			Max. prospective line I _{sc}	Max. available nominal current I _n (1)			Catalog number
500 V	575 V	690 V	at 500 V	at 600 V	at 690 V		500 V	575 V	690 V	
kW	HP	kW	A	A	A	kA	A	A	A	
2.2	3	3	5.2	4.4	5.2	22	4.5	3.9	4.5	ATV61HU30Y
3	-	4	6.8	-	6.6	22	5.8	-	5.8	ATV61HU40Y
4	5	5.5	8.6	7.2	8.6	22	7.5	6.1	7.5	ATV61HU55Y
5.5	7.5	7.5	11.2	9.5	11.2	22	10	9	10	ATV61HU75Y
7.5	10	11	14.6	12.3	15.5	22	13.5	11	13.5	ATV61HD11Y
11	15	15	19.8	16.7	20.2	22	18.5	17	18.5	ATV61HD15Y
15	20	18.5	24	21	24	22	24	22	24	ATV61HD18Y
18.5	25	22	29	24	27	22	29	27	29	ATV61HD22Y
22	30	30	33	28	34	22	35	32	35	ATV61HD30Y
30	40	37	48	41	41	22	47	41	43	ATV61HD37Y
37	50	45	61	51	55	22	59	52	54	ATV61HD45Y
45	60	55	67	57	63	22	68	62	62	ATV61HD55Y
55	75	75	84	70.5	82	22	85	77	84	ATV61HD75Y
75	100	90	110	92	102	22	104	99	104	ATV61HD90Y

(1) These power ratings and currents are given for an ambient temperature of 50°C (122°F) at the factory-set switching frequency, used in continuous operation (factory-set switching frequency of 4 kHz for ATV61H U22S6X to U75S6X and ATV61H U30Y to D30Y drives, and 2.5 kHz for ATV61H D37Y to D90Y).

Above this factory setting, the drive will reduce the switching frequency automatically in the event of excessive temperature rise.

For continuous operation above the factory setting, derating must be applied to the nominal drive current in accordance with the curves on page 14.

(2) Current on a line supply with the "Max. prospective line I_{sc}" indicated and for a drive without any external options.

Note

The maximum transient current for 60 s corresponds to 120% of the maximum nominal current I_n.

Dimensions and weights

With graphic display terminal

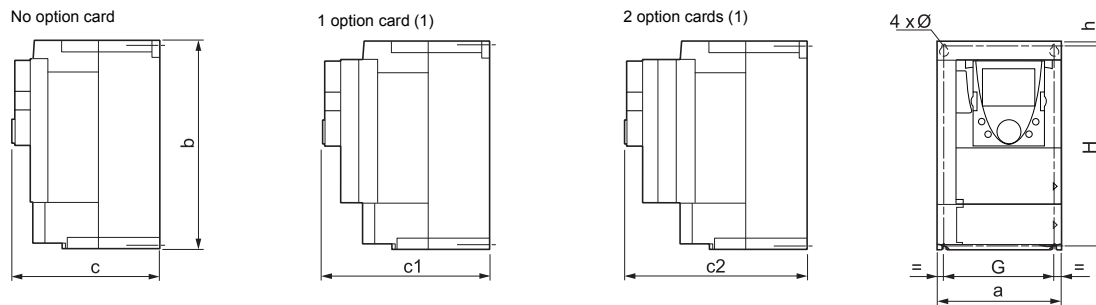

ATV61H	a	b	c	c1	c2	G	H	h	Ø	For screws	Weight
	mm (in.)	mm (in.)	mm (in.)	mm (in.)	mm (in.)	mm (in.)	mm (in.)	mm (in.)	mm (in.)		kg (lb.)
075M3, U15M3, 075N4, U15N4,U22N4	130 (5.12)	230 (9.05)	175 (6.89)	198 (7.80)	221 (8.70)	113.5 (4.47)	220 (8.66)	5 (0.20)	5 (0.20)	M4	3 (6.61)
U22M3, U30M3, U40M3, U30N4, U40N4	155 (6.10)	260 (10.23)	187 (7.36)	210 (8.27)	233 (9.17)	138 (5.43)	249 (9.80)	4 (0.16)	5 (0.20)	M4	4 (8.82)
U55M3, U55N4, U75N4	175 (6.89)	295 (11.61)	187 (7.36)	210 (8.27)	233 (9.17)	158 (6.22)	283 (11.14)	6 (0.24)	5 (0.20)	M4	5.5 (12.13)
U75M3, D11N4 U22S6X ... U75S6X	210 (8.27)	295 (11.61)	213 (8.39)	236 (9.29)	259 (10.20)	190 (7.48)	283 (11.14)	6 (0.24)	6 (0.24)	M5	7 (15.43)
D11M3X, D15M3X, D15N4, D18N4	230 (9.05)	400 (15.75)	213 (8.39)	236 (9.29)	259 (10.20)	210 (8.26)	386 (15.20)	8 (0.31)	6 (0.24)	M5	9 (19.84)
D18M3X, D22M3X, D22N4, U30Y ... D30Y	240 (9.45)	420 (16.54)	236 (9.29)	259 (10.20)	282 (11.10)	206 (8.11)	403 (15.87)	11 (0.45)	6 (0.24)	M5	30 (66.14)
D30N4, D37N4	240 (9.45)	550 (21.65)	266 (10.47)	289 (11.38)	312 (12.28)	206 (8.11)	531.5 (20.93)	11 (0.45)	6 (0.24)	M5	37 (81.57)
D30M3X, D37M3X, D45M3X	320 (12.60)	550 (21.65)	266 (10.47)	289 (11.38)	312 (12.28)	280 (11.02)	524 (20.93)	20 (0.79)	9 (0.35)	M8	37 (81.57)
D45N4, D55N4, D75N4, D37Y ... D90Y	320 (12.60)	630 (24.80)	290 (11.42)	313 (12.32)	334 (13.15)	280 (11.02)	604.5 (23.80)	15 (0.59)	9 (0.35)	M8	45 (99.21)

Without graphic display terminal

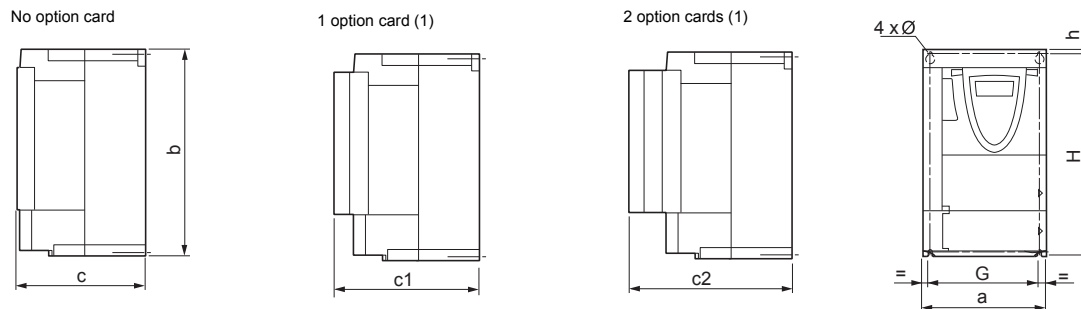

For a drive without a graphic display terminal, dimensions c, c1 and c2 in the table above are reduced by 26 mm (1.01 in.). The other dimensions are unchanged.

(1) For the addition of I/O extension cards, communication cards, or the "Controller Inside" programmable card.

Mounting and temperature conditions

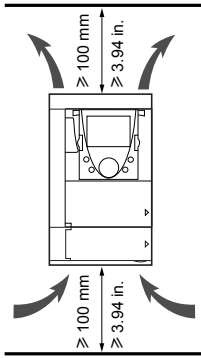

Install the drive vertically to $\pm 10^\circ$.
 Do not place it close to heating elements.
 Leave sufficient free space to ensure that the air required for cooling purposes can circulate from the bottom to the top of the unit.

Free space in front of the drive: 10 mm (0.39 in.) minimum

When IP20 protection is adequate, it is recommended that the protective cover on the top of the drive is removed as shown below.

Removing the protective cover

ATV61H 075M3 to D15M3X, ATV61H075N4 to D18N4 and
 ATV61H U22S6X to U75S6X

ATV61H D18M3X to D45M3X, ATV61H D22N4 to D75N4
 and ATV61H U30Y to D90Y

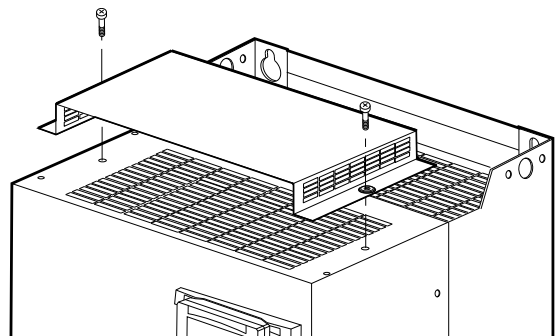
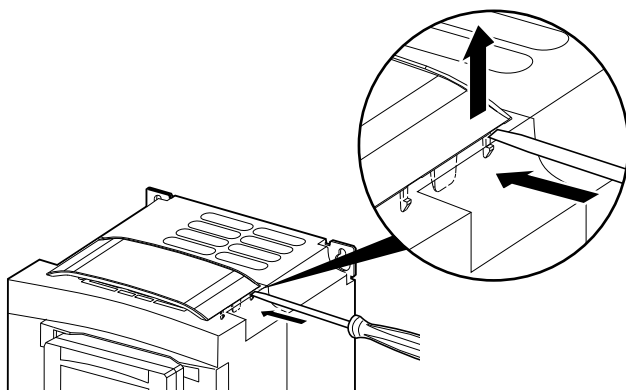

Two types of mounting are possible:

Type A mounting Free space ≥ 50 mm (≥ 1.97 in.) on each side, with protective cover fitted

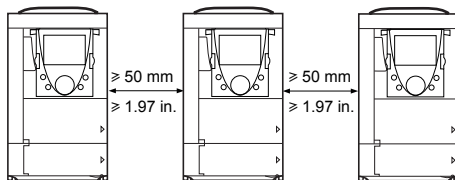

Type B mounting Drives mounted side by side, with the protective cover removed (the degree of protection becomes IP20)

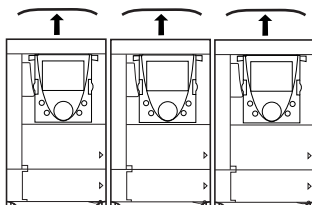

Mounting and temperature conditions

Derating curves

Derating curves for the drive current I_n as a function of the temperature, switching frequency and type of mounting.

ATV61H 075M3 to D15M3X and ATV61H 075N4 to D18N4

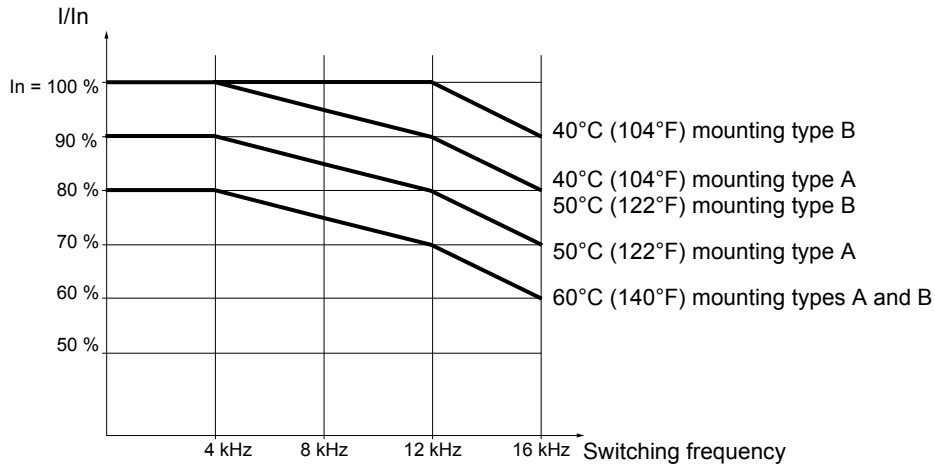

ATV61H D22N4 and ATV61H D30N4 (1)

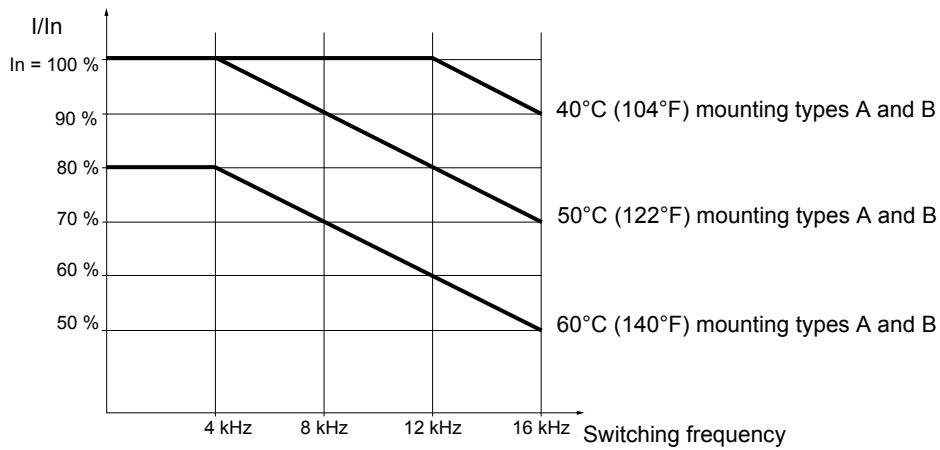

ATV61H D18M3X to D45M3X and ATV61H D37N4 to D75N4 (1)

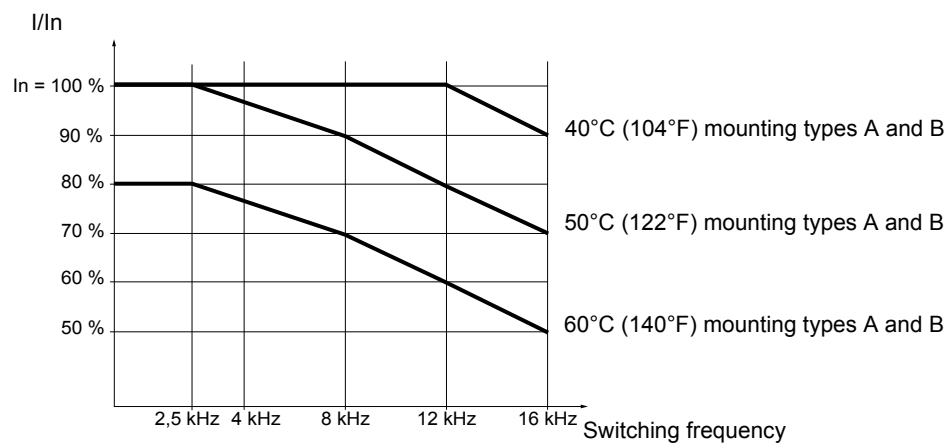

For intermediate temperatures (e.g. 55°C (131°F)), interpolate between two curves.

(1) Above 50°C (122°F), these drives must be equipped with a control card fan kit. Please refer to the catalog.

Mounting and temperature conditions

Derating for ATV61H●●●S6X

Mounting type A and B:

ATV61H●●●S6X drives can operate with a switching frequency 2,5...6kHz up to 50°C without derating.

Mounting type C:

ATV61H●●●S6X drives can operate with a switching frequency 2,5...6kHz up to 60°C without derating

For operation above 50°C (122°F), power supply voltage must be limited up to 600V+5%.

ATV61H U30Y to D30Y

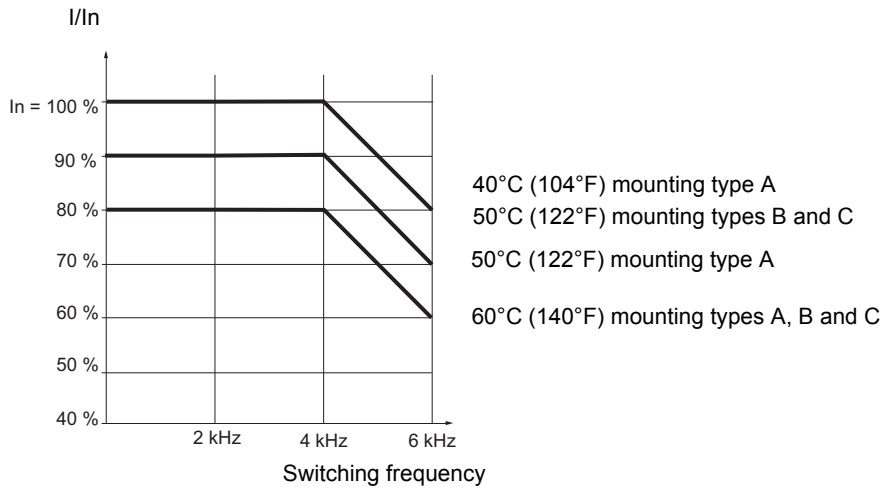

ATV61H D37Y to D90Y

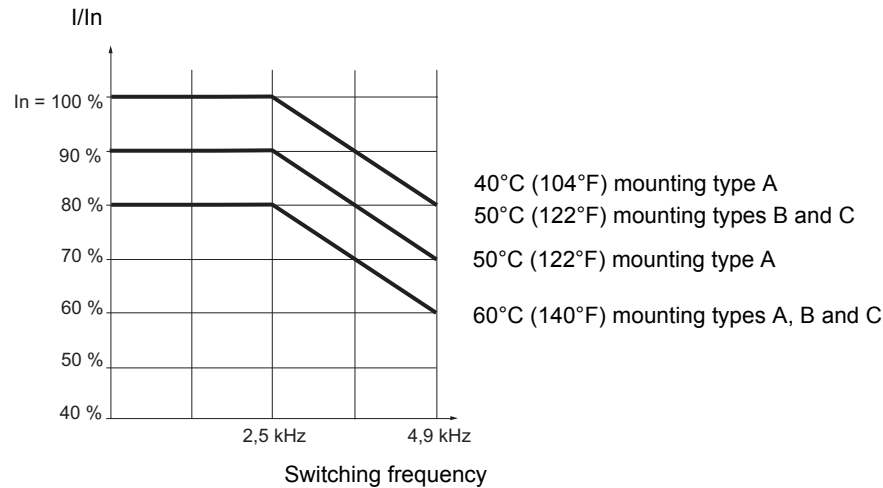

For intermediate temperatures (e.g. 55°C (131°F)), interpolate between two curves.

Mounting in a wall-mounted or floor-standing enclosure

Follow the mounting precautions on the previous pages.
To ensure proper air circulation in the drive:

- Fit ventilation grilles.
- Ensure that the ventilation is adequate: if not, install a forced ventilation unit with a filter.
- Use special IP54 filters.

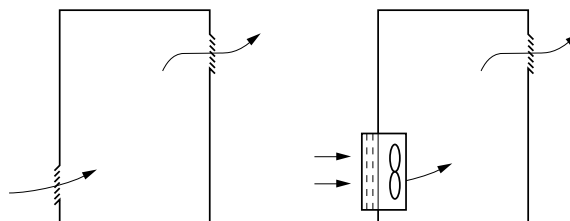

Dust and damp proof metal wall-mounted or floor-standing enclosure (IP 54 degree of protection)

The drive must be mounted in a dust and damp proof enclosure in certain environmental conditions: dust, corrosive gases, high humidity with risk of condensation and dripping water, splashing liquid, etc.

To avoid hot spots in the drive, add a fan to circulate the air inside the enclosure, catalog number VW3 A9 4●● (see catalog).

Mounting the drive in the enclosure

Dissipated power

These levels of power dissipation are given for operation at nominal load and for the factory-set switching frequency.

ATV61H	Dissipated power (1) W
075M3	66
U15M3	101
U22M3	122
U30M3	154
U40M3	191
U55M3	293
U75M3	363
D11M3X	566
D15M3X	620
D18M3X	657
D22M3X	766
D30M3X	980
D37M3X	1154
D45M3X	1366

ATV61H	Dissipated power (1) W
075N4	44
U15N4	64
U22N4	87
U30N4	114
U40N4	144
U55N4	178
U75N4	217
D11N4	320
D15N4	392
D18N4	486
D22N4	574
D30N4	799
D37N4	861
D45N4	1060
D55N4	1210
D75N4	1720

ATV61H	Dissipated power (1) W
U22S6X	100
U30S6X	118
U40S6X	143
U55S6X	183
U75S6X	244

ATV61H	Dissipated power (1) W
U30Y	111
U40Y	119
U55Y	136
U75Y	158
D11Y	182
D15Y	227
D18Y	300
D22Y	386
D30Y	463
D37Y	716
D45Y	716
D55Y	911
D75Y	1087
D90Y	1545

(1) Add 7 W to this value for each option card added

Ensure that the flow of air in the enclosure is at least equal to the value given in the table below for each drive.

ATV61H	Flow rate	
	m ³ /hour	ft ³ /min
075M3, U15M3, 075N4, U15N4, U22N4	17	10
U22M3, U30M3, U40M3, U30N4, U40N4	56	33
U55M3, U55N4, U75N4	112	66
U75M3, D11N4, U22S6X to U75S6X	163	96
D11M3X, D15M3X, D15N4, D18N4	252	148
D18M3X, D22M3X, D22N4, D30N4, D37N4	203	119
D30M3X, D37M3X, D45M3X, D45N4, D55N4, D75N4	406	239

ATV61H	Flow rate	
	m ³ /hour	ft ³ /min
U30Y to D37Y	330	194
D45Y to D90Y	406	234

Mounting in a wall-mounted or floor-standing enclosure

Dust and damp proof flange mounting

This mounting is used to reduce the power dissipated in the enclosure by locating the power section outside the enclosure. This requires the use of a dust and damp proof flange-mounting kit VW3 A9 501...509 (please refer to the catalog). The degree of protection for the drives mounted in this way becomes IP54.

To install the kit on the drive, please refer to the manual supplied with the kit.

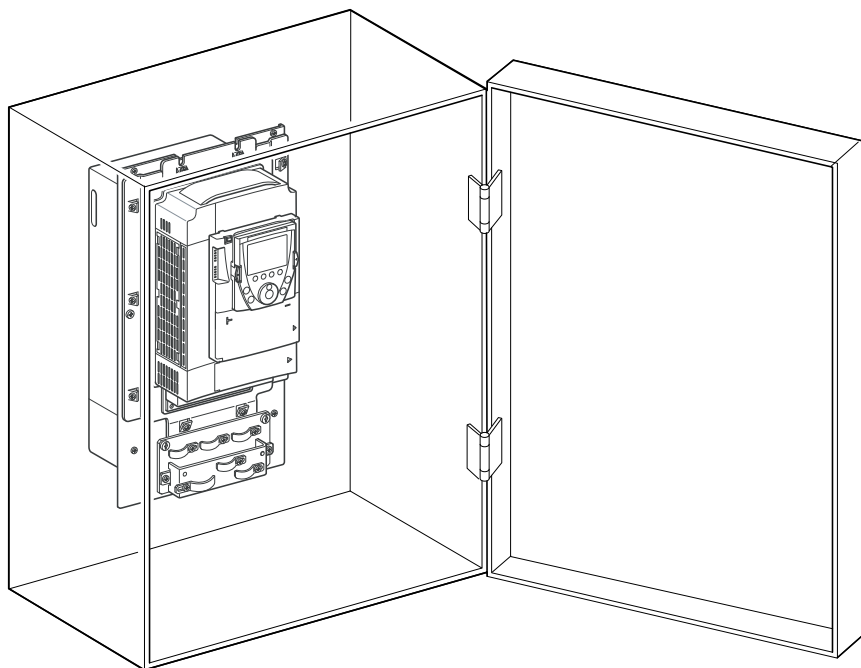

Example: ATV61HU55N4

Power dissipated inside the enclosure for dust and damp proof flange-mounting

These levels of power dissipation are given for operation at nominal load and for the factory-set switching frequency.

ATV61H	Dissipated power (1)	ATV61H	Dissipated power (1)	ATV61H	Dissipated power (1)	ATV61H	Dissipated power (1)
	W		W		W		W
075M3	27	075N4	26	U22S6X	60	U30Y	71
U15M3	30	U15N4	28	U30S6X	70	U40Y	71
U22M3	38	U22N4	30	U40S6X	75	U55Y	73
U30M3	38	U30N4	35	U55S6X	80	U75Y	75
U40M3	41	U40N4	40	U75S6X	85	D11Y	77
U55M3	59	U55N4	50			D15Y	81
U75M3	67	U75N4	55			D18Y	87
D11M3X	80	D11N4	65			D22Y	94
D15M3X	84	D15N4	85			D30Y	100
D18M3X	114	D18N4	86			D37Y	120
D22M3X	124	D22N4	110			D45Y	120
D30M3X	144	D30N4	135			D55Y	133
D37M3X	161	D37N4	137			D75Y	144
D45M3X	180	D45N4	165			D90Y	158
		D55N4	178				
		D75N4	225				

(1) Add 7 W to this value for each option card added

Installing the graphic display terminal

Installing the graphic display terminal on the drive

Drives with catalog numbers ending in the letter Z are supplied without a graphic display terminal (VW3 A1 101). This can be ordered separately. It is installed on the drive as shown below.

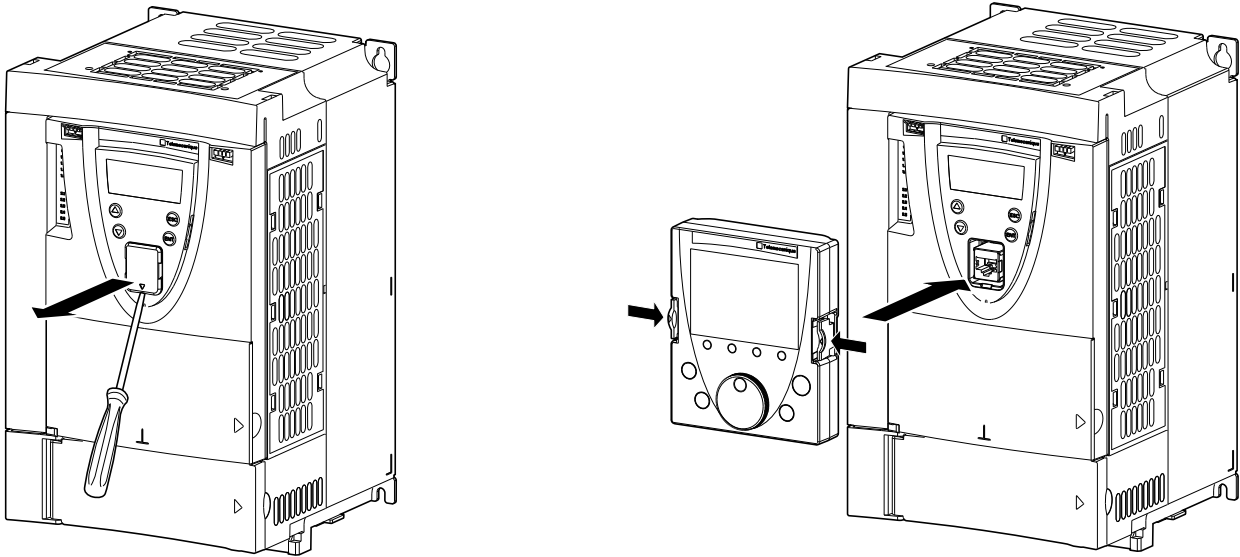

The graphic display terminal can be connected or disconnected with the power on. Before disconnecting it, drive control via the display terminal must be disabled (refer to the Programming Manual).

Position of the charging LED

Before working on the drive, turn it off, wait until the red capacitor charging LED has gone out, then measure the DC bus voltage.

Position of the capacitor charging LED

ATV61H 075M3 to D15M3X,
ATV61H 075N4 to D18N4 and
ATV61H U22S6X to U75S6X

ATV61H D18M3 to D45M3X,
ATV61H D22N4 to D75N4 and
ATV61H U30Y to D90Y

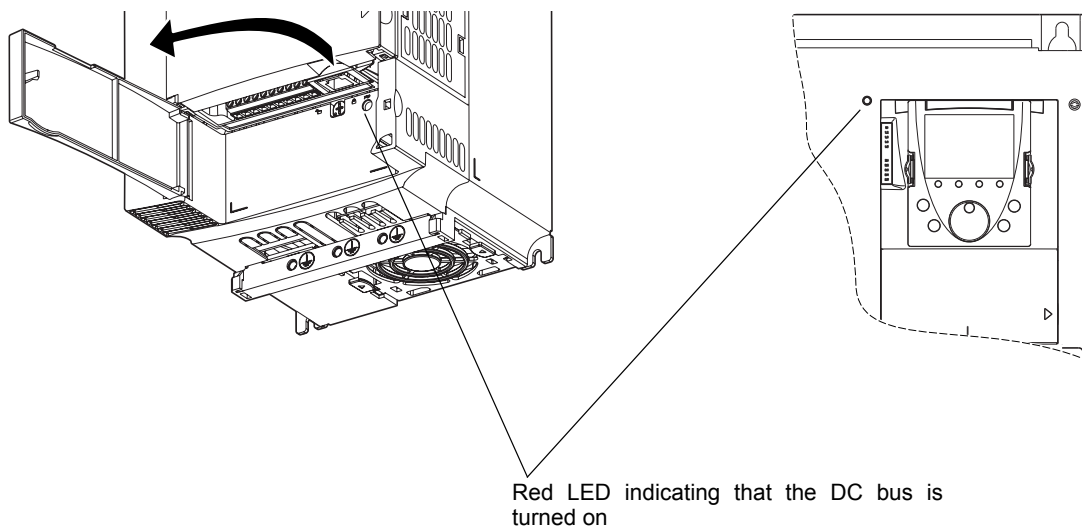

Procedure for measuring the DC bus voltage

⚠ DANGER

HAZARDOUS VOLTAGE

Read and understand the instructions on page 5 before performing this procedure.
Failure to follow this instruction will result in death or serious injury.

The DC bus voltage can exceed 1,000 V $\overline{\text{---}}$. Use a properly rated voltage sensing device when performing this procedure. To measure the DC bus voltage:

- 1 Disconnect the drive power supply.
- 2 Wait 15 minutes to allow the DC bus capacitors to discharge.
- 3 Measure the voltage of the DC bus between the PA/+ and PC/- terminals to check whether the voltage is less than 45 V $\overline{\text{---}}$. See page 26 for the arrangement of the power terminals.
- 4 If the DC bus capacitors have not discharged completely, contact your local Schneider Electric representative (do not repair or operate the drive).

Installing option cards

These should ideally be installed once the drive is mounted and before wiring it. Check that the red capacitor charging LED is off. Measure the DC bus voltage in accordance with the procedure indicated on page 19. The option cards are installed under the drive control front panel. If the drive has a graphic display terminal, remove it, then remove the control front panel as indicated below.

Removing the control front panel

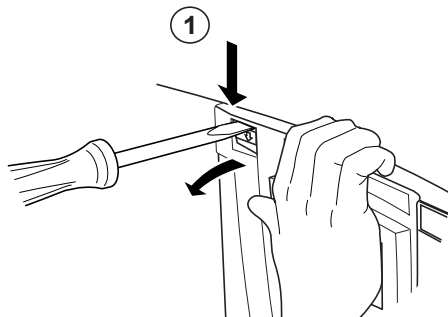

- Using a screwdriver, press down on the catch and pull to release the left-hand part of the control front panel

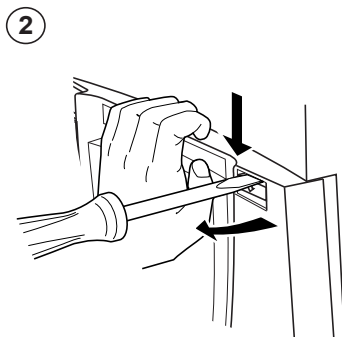

- Do the same on the right-hand side

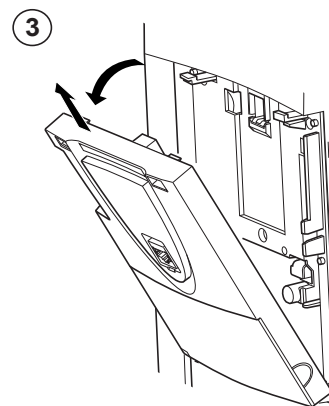

- Pivot the control front panel and remove it

Installing an encoder interface card

There is a special slot on the drive for adding an encoder interface card.

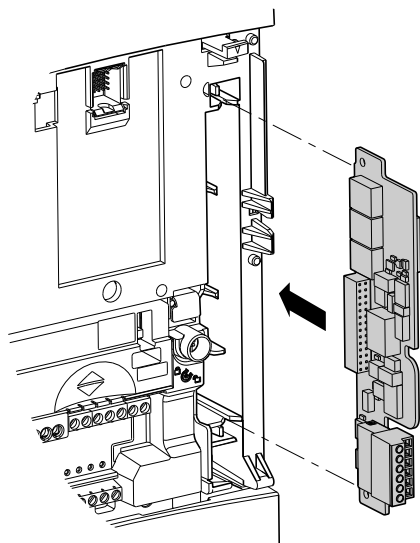

- If an I/O or communication option card or a “Controller Inside” programmable card has already been installed, remove it so you can access the slot for the encoder interface card.

Installing option cards

Installing an I/O extension card, a communication card or a “Controller Inside” programmable card

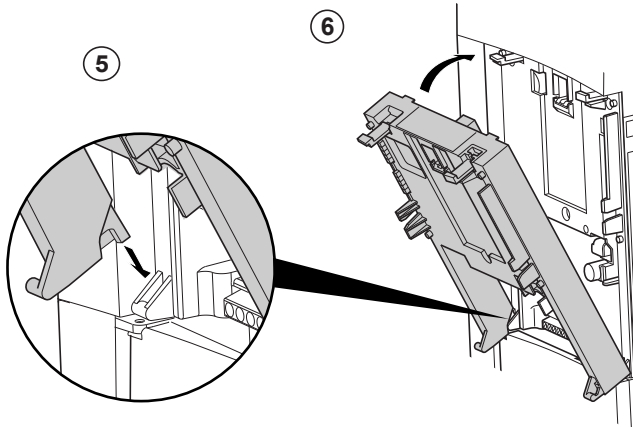

①, ② and ③ Remove the control front panel (see previous page)

④ Install an encoder interface card (if used) (see previous page)

⑤ Position the option card on the clasps

⑥ Then pivot it until it clicks into place

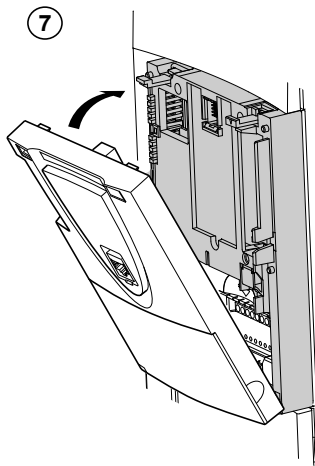

⑦ Replace the control front panel over the option card (same procedure as for installing the option card, see ⑤ and ⑥)

Installing the EMC plates

ATV61H 075M3 to D15M3X, ATV61H 075N4 to D18N4 and ATV61H U22S6X to U75S6X

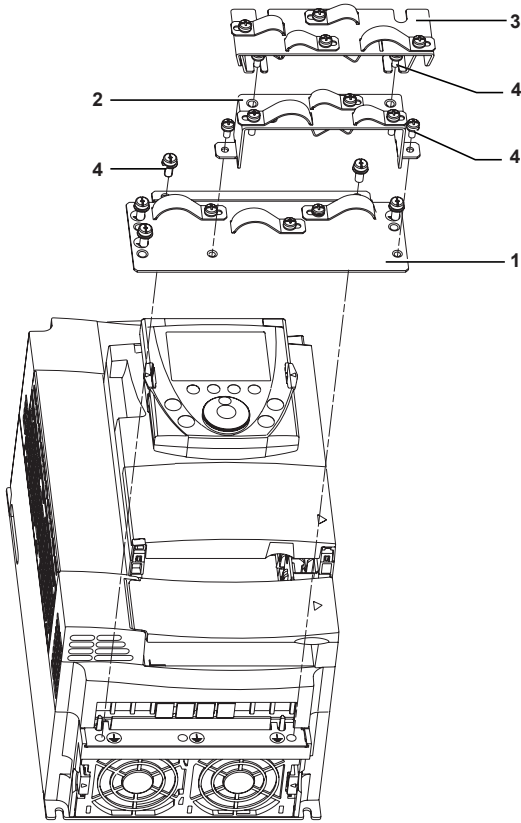

ATV61H D18M3X to D45M3X, ATV61H D22N4 to D75N4 and ATV61H U30Y to D90Y

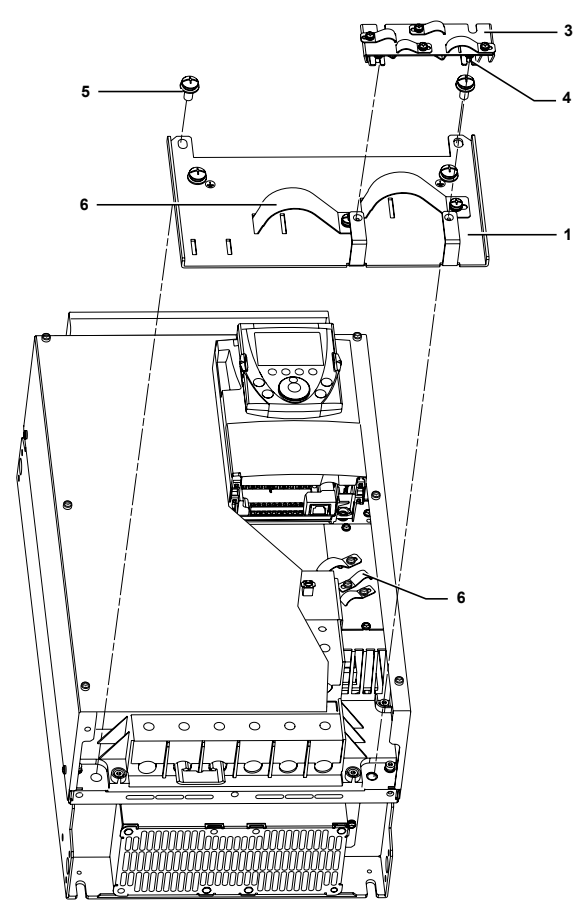

Installing the EMC clamps

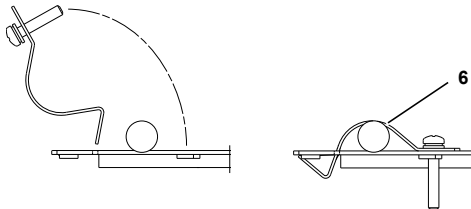

- 1 - EMC plate for connecting the power cables
- 2 - EMC plate for connecting the control cables (only for ATV61H 075M3 to D15M3X, ATV61H 075N4 to D18N4 and ATV61H U22S6X to U75S6X)
- 3 - EMC plate for connecting the I/O option card cables (supplied with the option cards)
- 4 - M4 screws (supplied)
- 5 - M8 screws (supplied)
- 6 - EMC clamps with captive screws (supplied)

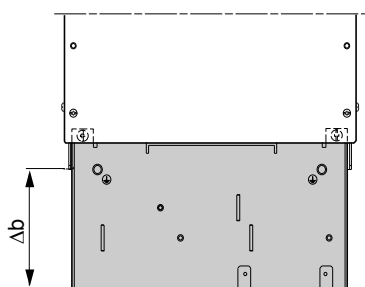

ATV61H	Δb	
	mm	in.
075M3 to U40M3, 075N4 to U40N4	55	2.17
U55M3 to D15M3X, U55N4 to D18N4, U22S6X to U75S6X	65	2.56
D18M3X to D45M3X, D22N4 to D75N4, U30Y to D90Y	120	4.72

Wiring precautions

Power section

The drive must be connected to the protective ground. To comply with current regulations concerning high leakage currents (above 3.5 mA), use at least a 10 mm² (AWG 6) protective conductor or 2 protective conductors with the same cross-section as the power section AC supply conductors.

DANGER

HAZARDOUS VOLTAGE

Connect the device to the protective ground using the grounding point provided, as shown in the figure below. The drive panel must be connected to the protective ground before power is applied.

Failure to follow these instructions will result in death or serious injury.

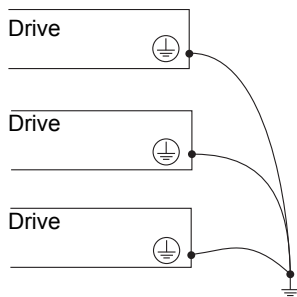

- Check whether the resistance to the protective ground is one ohm or less. Connect a number of drives to the protective ground as shown in the diagram (see left). Do not lay protective grounding cables in a loop or in series.

WARNING

IMPROPER WIRING PRACTICES

- The ATV61 drive will be damaged if input line voltage is applied to the output terminals (U/T1, V/T2, W/T3).
- Check the power connections before powering up the ATV61 drive.
- If replacing another drive, verify that all wiring connections to the ATV61 drive comply with all wiring instructions in this manual.

Failure to follow these instructions can result in death, serious injury or equipment damage.

When upstream protection by means of a “residual current device” is required by the installation standards, a type A device should be used for single-phase drives and type B for three-phase drives. Choose a suitable model integrating:

- HF current filtering
- A time delay to prevent tripping caused by the load from stray capacitance on power-up. The time delay is not possible for 30 mA devices. In this case, choose devices with immunity against nuisance tripping, for example “residual current devices” with reinforced immunity from the s.i range (Merlin Gerin brand).

If the installation includes several drives, provide one residual current device per drive.

WARNING

INADEQUATE OVERCURRENT PROTECTION

- Overcurrent protective devices must be properly coordinated.
- The Canadian Electricity Code and the National Electrical Code require branch circuit protection. Use the fuses recommended on the drive nameplate to achieve published short-circuit current ratings.
- Do not connect the drive to a power feeder whose short-circuit capacity exceeds the drive short-circuit current rating listed on the drive nameplate.

Failure to follow these instructions can result in death, serious injury or equipment damage.

Wiring recommendations

Keep the power cables separate from circuits in the installation with low-level signals (sensors, PLCs, measuring apparatus, video, telephone).

The motor cables must be at least 0.5 m (20 in.) long.

In certain situations where the motor cables have to be submerged in water, earth leakage currents can cause tripping, requiring the addition of output filters.

Do not use surge arresters or power factor correction capacitors on the variable speed drive output.

⚠ CAUTION
IMPROPER USE OF A BRAKING RESISTOR
<ul style="list-style-type: none"> • Only use the braking resistors recommended in our catalogs. • Wire the thermal protection contact on the resistor so that the drive power supply is disconnected immediately in the event of a fault (refer to the manual supplied with the resistor).
Failure to follow these instructions can result in injury and/or equipment damage.

Control section

Keep the control circuits away from the power circuits. For control and speed reference circuits, we recommend using shielded twisted cables with a pitch of between 25 and 50 mm (0.98 and 1.97 in.) and connecting the shielding to ground at each end.

If using conduit, do not lay the motor, power supply and control cables in the same conduit. Keep metal conduit containing power supply cables at least 8 cm (3 in.) away from metal conduit containing control cables. Keep non-metal conduits or cable ducts containing power supply cables at least 31 cm (12 in.) away from metal conduits containing control cables. If it is necessary for control and power cables to cross each other, be sure they cross at right angles.

Length of motor cables

ATV61H		0 m (0 ft)	10 m (32.8 ft)	50 m (164 ft)	100 m (328 ft)	150 m (492 ft)	300 m (984 ft)	1000 m (3280 ft)
075M3 to U75M3 075N4 to D15N4	Shielded cable							
	Unshielded cable							
D11M3X to D45M3X D18N4 to D75N4	Shielded cable							
	Unshielded cable							
U22S6X to U75S6X U30Y to D90Y	Shielded cable		See catalog					

With dv/dt filters

With sinus filters

Choice of associated components:
Please refer to the catalog.

Power terminals

Access to the power terminals

ATV61H 075M3 to D15M3X and ATV61H 075N4 to D18N4 and ATV61H U22S6X to U75S6X
Unlock the power part access flap and remove it as shown below.

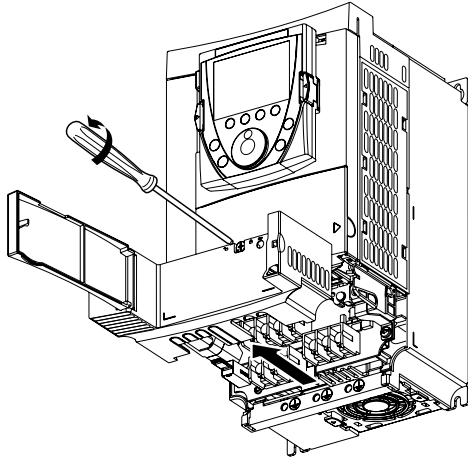

Example of ATV61HU22M3

ATV61H D18M3X to D45M3X, ATV61H D22N4 to D75N4 and ATV61H U30Y to D90Y
To access the power terminals, remove the front panel as shown below.

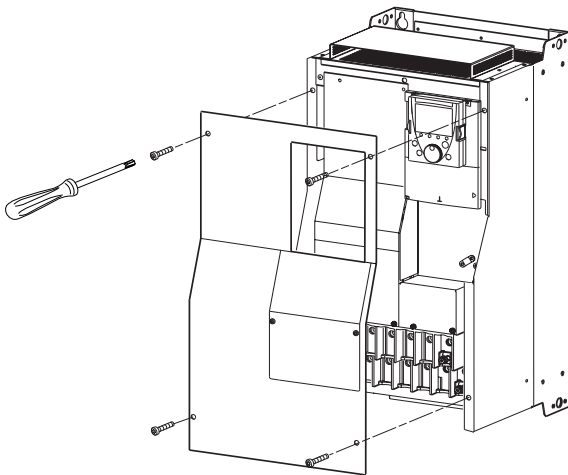

Example of ATV61HD75N4

Characteristics and functions of the power terminals

Terminal	Function
\perp	Protective ground connection terminal
R/L1 S/L2 T/L3	Power section AC supply
PO	DC bus + polarity
PA/+	Output to braking resistor (+ polarity)
PB	Output to braking resistor
PC/-	DC bus - polarity
U/T1 V/T2 W/T3	Outputs to the motor

 Only remove the link between PO and PA/+ if a DC choke has been added. The screws on the PO and PA/+ terminals must always be fully tightened as there is a high current flowing in the commoning link.

Power terminals

Arrangement of the power terminals

**ATV61H 075M3, U15M3, U22M3, U30M3, U40M3,
075N4, U15N4, U22N4, U30N4, U40N4**

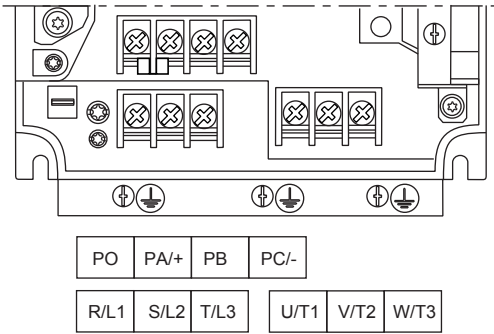

ATV61H	Maximum wire size		Tightening torque
	mm ²	AWG	Nm (lb.in)
075M3, U15M3, U22M3, U30M3, U40M3, 075N4, U15N4, U22N4, U30N4, U40N4	4	10	1.4 (12.3)

**ATV61H U55M3, U75M3, D11M3X, D15M3X,
U55N4, U75N4, D11N4, D15N4, D18N4,
U22S6X, U30S6X, U40S6X, U55S6X, U75S6X**

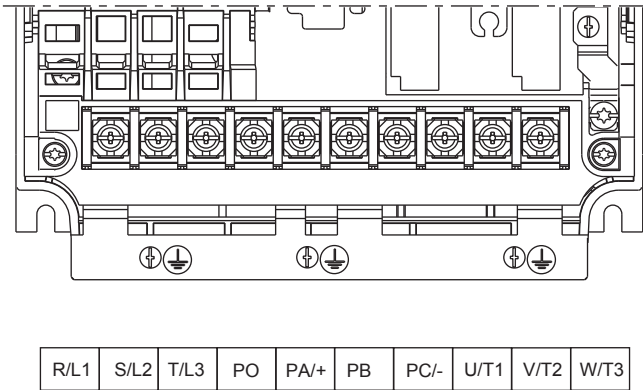

ATV61H	Maximum wire size		Tightening torque
	mm ²	AWG	Nm (lb.in)
U55M3, U55N4, U75N4	6	8	3 (26.5)
U75M3, D11N4, U22S6X to U75S6X	16	4	3 (26.5)
D11M3X, D15M3X, D15N4, D18N4	35	2	5.4 (47.7)

**ATV61H D18M3X, D22M3X, D30M3X, D37M3X, D45M3X,
D22N4, D30N4, D37N4, D45N4, D55N4, D75N4**

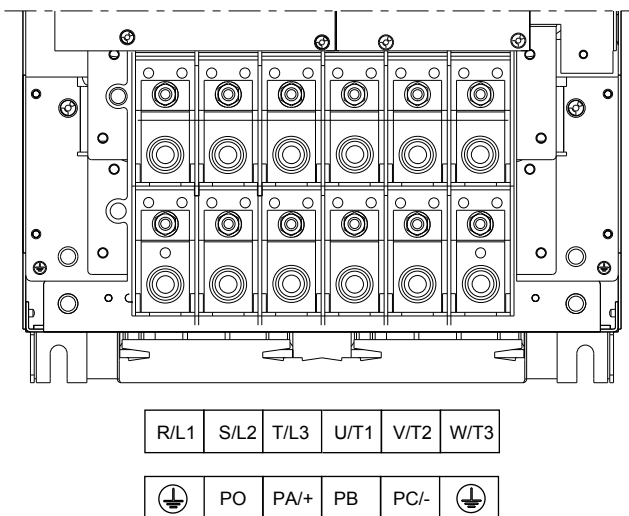

ATV61H	Maximum wire size		Tightening torque
	mm ²	AWG	Nm (lb.in)
D18M3X, D22M3X, D22N4, D30N4, D37N4, U30Y to D30Y	50	1/0	12 (102)

ATV61H	Maximum wire size		Tightening torque
	mm ²	kcmils	Nm (lb.in)
D30M3X, D37M3X, D45M3X, D45N4, D55N4, D75N4, D37Y to D90Y	150	300	41 (360)

Control terminals

Access to the control terminals

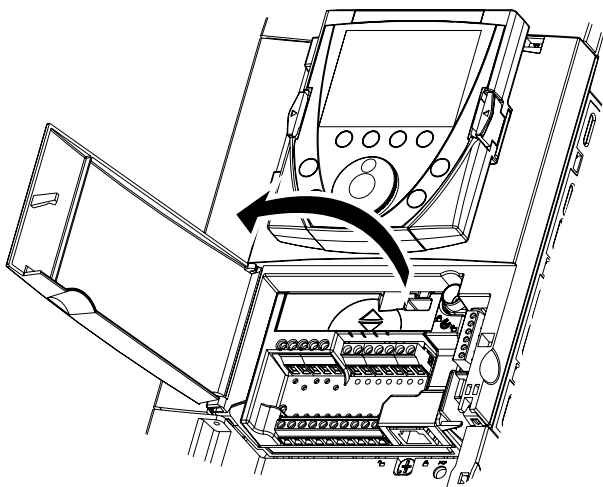

To access the control terminals, open the cover on the control front panel.

Removing the terminal card

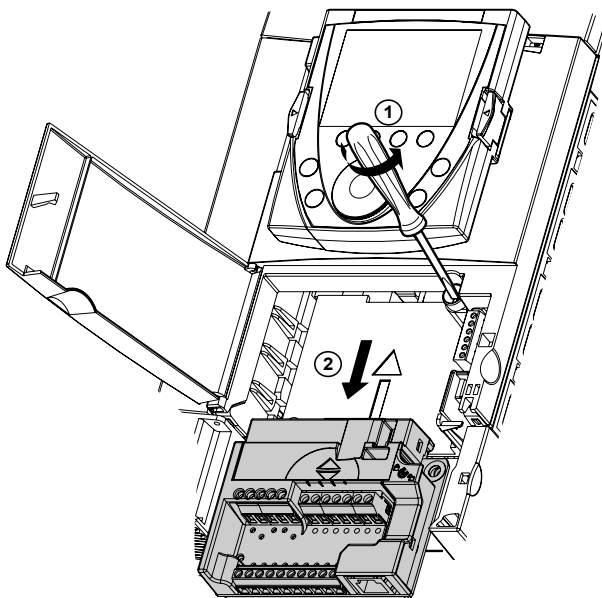

To make it easier to wire the drive control section, the control terminal card can be removed.

- Undo the screw until the spring is fully extended
- Remove the card by sliding it downwards

CAUTION

IMPROPERLY SECURED TERMINAL CARD

When replacing the control terminal card, it is essential to fully tighten the captive screw.

Failure to follow this instruction can result in injury and/or equipment damage.

Arrangement of the control terminals

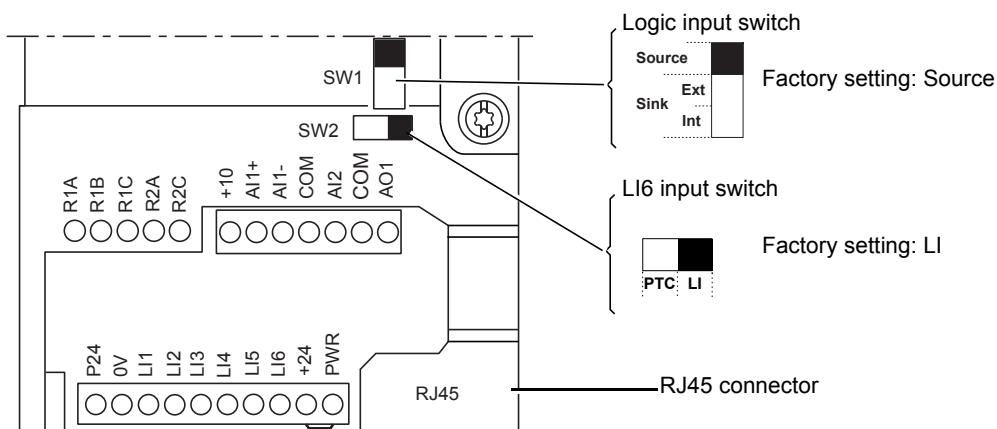

Maximum wire size:
2.5 mm² - AWG 14

Max. tightening torque:
0.6 Nm - 5.3 lb.in

Note: The ATV61 is supplied with a link between the PWR and +24 terminals.

Control terminals

Characteristics and functions of the control terminals

Terminal	Function	Electrical characteristics									
R1A R1B R1C	Common point C/O contact (R1C) of programmable relay R1	<ul style="list-style-type: none"> Minimum switching capacity: 3 mA for 24 V --- Maximum switching capacity on resistive load: 5 A for 250 V \sim or 30 V --- 									
R2A R2C	N/O contact of R2 programmable relay	<ul style="list-style-type: none"> Maximum switching current on inductive load ($\cos \varphi = 0.4$ L/R = 7 ms): 2 A for 250 V \sim or 30 V --- Reaction time: 7 ms \pm 0.5 ms Service life: 100,000 operations at max. switching power 									
+10	+ 10 V --- power supply for 1 to 10 k Ω reference potentiometer	<ul style="list-style-type: none"> +10 V --- (10.5 V \pm 0.5 V) 10 mA max. 									
A11+ A11 -	Differential analog input A11	<ul style="list-style-type: none"> -10 to +10 V --- (max. safe voltage 24 V) Reaction time: 2 ms \pm 0.5 ms, 11-bit resolution + 1 sign bit Accuracy \pm 0.6% for $\Delta\theta = 60^\circ\text{C}$ (140°F), linearity \pm 0.15% of max. value 									
COM	Analog I/O common	0V									
A12	Depending on software configuration: Analog voltage input or Analog current input	<ul style="list-style-type: none"> Analog input 0 to +10 V --- (max. safe voltage 24 V), impedance 30 kΩ or Analog input X - Y mA, X and Y being programmable from 0 to 20 mA Impedance 250 Ω Reaction time: 2 ms \pm 0.5 ms 11-bit resolution, accuracy \pm 0.6% for $\Delta\theta = 60^\circ\text{C}$ (140°F), linearity \pm 0.15% of max. value 									
COM	Analog I/O common	0V									
AO1	Depending on software configuration: Analog voltage output or Analog current output or Logic output	<ul style="list-style-type: none"> Analog output 0 to +10 V ---, load impedance greater than 50 kΩ or Analog output X - Y mA, X and Y being programmable from 0 to 20 mA Max. load impedance 500 Ω 10-bit resolution, reaction time: 2 ms \pm 0.5 ms Accuracy \pm 1% for $\Delta\theta = 60^\circ\text{C}$ (140°F), linearity \pm 0.2% of max. value or logic output : 0 to +10V or 0 to 20 mA. 									
P24	Input for external +24 V --- control power supply	<ul style="list-style-type: none"> +24 V --- (min. 19 V, max. 30 V) Power 30 Watts 									
0V	Logic input common and 0 V of P24 external power supply	0V									
L11 L12 L13 L14 L15	Programmable logic inputs	<ul style="list-style-type: none"> +24 V --- (max. 30 V) Impedance 3.5 kΩ Reaction time: 2 ms \pm 0.5 ms <table border="1" style="margin-left: auto; margin-right: auto;"> <thead> <tr> <th>Switch SW1</th> <th>State 0</th> <th>State 1</th> </tr> </thead> <tbody> <tr> <td>Source (factory setting)</td> <td>< 5 V ---</td> <td>> 11 V ---</td> </tr> <tr> <td>Sink Int or Sink Ext</td> <td>> 16 V ---</td> <td>< 10 V ---</td> </tr> </tbody> </table>	Switch SW1	State 0	State 1	Source (factory setting)	< 5 V ---	> 11 V ---	Sink Int or Sink Ext	> 16 V ---	< 10 V ---
Switch SW1	State 0	State 1									
Source (factory setting)	< 5 V ---	> 11 V ---									
Sink Int or Sink Ext	> 16 V ---	< 10 V ---									
L16	Depending on the position of switch SW2: - Programmable logic input or - Input for PTC probes	<ul style="list-style-type: none"> Switch SW2 on LI (factory setting) Same characteristics as logic inputs L11 to L15 or Switch SW2 on PTC Trip threshold 3 kΩ, reset threshold 1.8 kΩ Short-circuit detection threshold < 50Ω 									
+24	Logic input power supply	<ul style="list-style-type: none"> Switch SW1 in Source or Sink Int position +24 V --- power supply (min. 21 V, max. 27 V), protected against short-circuits and overloads Max. current available for customers 200 mA Switch SW1 in Sink Ext position Input for external +24 V --- power supply for the logic inputs 									
PWR	Power Removal safety function input When PWR is not connected to the 24 V, the motor cannot be started (compliance with functional safety standard EN 954-1 and IEC/EN 61508)	<ul style="list-style-type: none"> 24 V --- power supply (max. 30 V) Impedance 1.5 kΩ State 0 if < 2 V, state 1 if > 17 V Reaction time: 10 ms 									

Option terminals

Logic I/O option card terminals (VW3 A3 201)

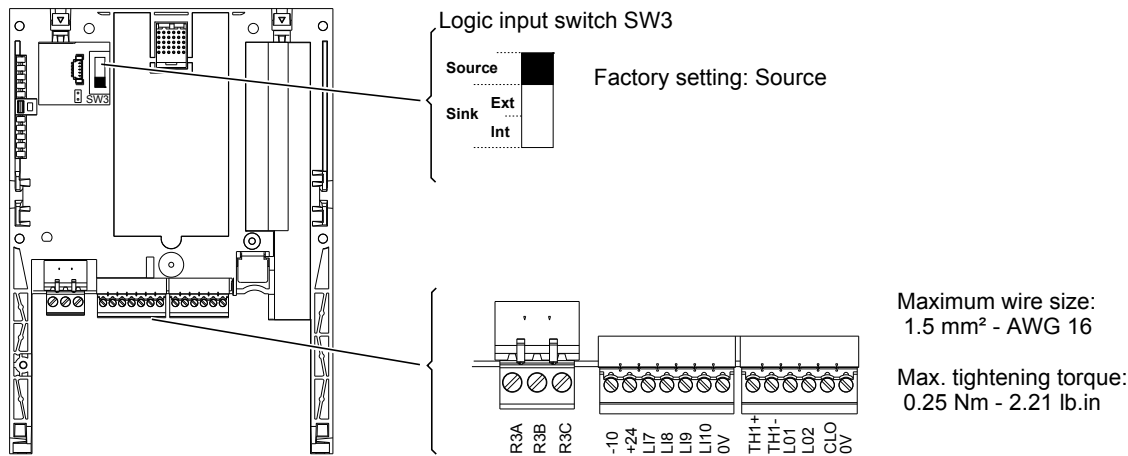

Characteristics and functions of the terminals

Terminal	Function	Electrical characteristics									
R3A R3B R3C	Common point C/O contact R3C of programmable relay R3	<ul style="list-style-type: none"> Minimum switching capacity: 3 mA for 24 V --- Maximum switching capacity on resistive load: 5 A for 250 V \sim or 30 V --- Maximum switching capacity on inductive load ($\cos \varphi = 0.4$ L/R = 7 ms): 2 A for 250 V \sim or 30 V --- Reaction time: 7 ms \pm 0.5 ms Service life: 100,000 operations 									
-10	-10 V --- power supply for 1 to 10 k Ω reference potentiometer	<ul style="list-style-type: none"> - 10 V --- (-10.5 V \pm 0.5 V) 10 mA max. 									
+24	Logic input power supply	<p>Switch SW3 in Source or Sink Int position</p> <ul style="list-style-type: none"> +24 V --- power supply (min. 21 V, max. 27 V), protected against short-circuits and overloads Max. current available for customers 200 mA (This current corresponds to the total consumption on the control card +24 and the option cards +24) <p>Switch SW3 in Sink Ext position</p> <ul style="list-style-type: none"> Input for external +24 V --- power supply for the logic inputs 									
L17 L18 L19 L110	Programmable logic inputs	<ul style="list-style-type: none"> +24 V --- power supply (max. 30 V) Impedance 3.5 kΩ Reaction time 2 ms \pm 0.5 ms <table border="1"> <thead> <tr> <th>Switch SW3</th> <th>State 0</th> <th>State 1</th> </tr> </thead> <tbody> <tr> <td>Source (factory setting)</td> <td>< 5 V ---</td> <td>> 11 V ---</td> </tr> <tr> <td>Sink Int or Sink Ext</td> <td>> 16 V ---</td> <td>< 10 V ---</td> </tr> </tbody> </table>	Switch SW3	State 0	State 1	Source (factory setting)	< 5 V ---	> 11 V ---	Sink Int or Sink Ext	> 16 V ---	< 10 V ---
Switch SW3	State 0	State 1									
Source (factory setting)	< 5 V ---	> 11 V ---									
Sink Int or Sink Ext	> 16 V ---	< 10 V ---									
0 V	0 V	0 V									
TH1+	PTC probe input	<ul style="list-style-type: none"> Trip threshold 3 kΩ, reset threshold 1.8 kΩ Short-circuit detection threshold < 50 Ω 									
TH1-											
LO1 LO2	Open collector programmable logic outputs	<ul style="list-style-type: none"> +24 V --- (max. 30 V) Max. current 200 mA for internal power supply and 200 mA for external power supply Reaction time: 2 ms \pm 0.5 ms 									
CLO	Logic output common										
0V	0 V	0 V									

Option terminals

Extended I/O option card terminals (VW3 A3 202)

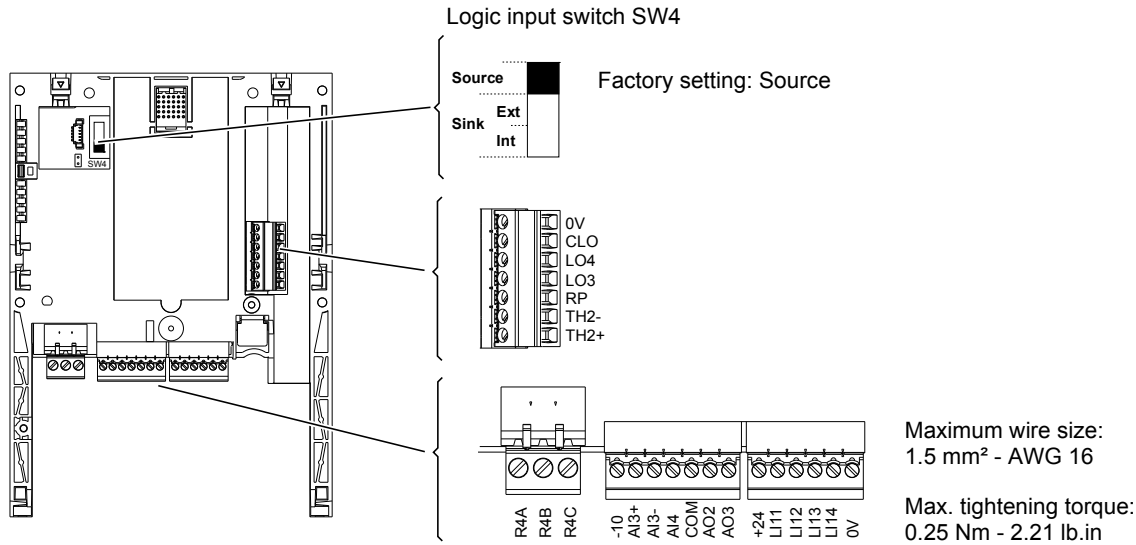

Characteristics and functions of the terminals

Terminal	Function	Electrical characteristics
R4A R4B R4C	Common point C/O contact R4C of programmable relay R4	<ul style="list-style-type: none"> Minimum switching capacity: 3 mA for 24 V $\overline{\text{DC}}$ Maximum switching capacity on resistive load: 5 A for 250 V \sim or 30 V $\overline{\text{DC}}$ Maximum switching capacity on inductive load ($\cos \varphi = 0.4$ L/R = 7 ms): 1.5 A for 250 V \sim or 30 V $\overline{\text{DC}}$ Reaction time: 10 ms \pm 1 ms Service life: 100,000 operations
-10	-10 V $\overline{\text{DC}}$ power supply for 1 to 10 k Ω reference potentiometer	<ul style="list-style-type: none"> - 10 V $\overline{\text{DC}}$ (-10.5 V \pm 0.5 V) 10 mA max.
AI3 +	+ polarity of the current differential analog input AI3	<ul style="list-style-type: none"> Analog input X - Y mA, X and Y being programmable from 0 to 20 mA, impedance 250 Ω Reaction time: 5 ms \pm 1 ms 11-bit resolution + 1 sign bit, accuracy \pm 0.6% for $\Delta\theta = 60^\circ\text{C}$ (140°F) Linearity \pm 0.15% of max. value
AI3-	- polarity of the current differential analog input AI3	
AI4	Depending on software configuration: Analog current input or Analog voltage input	<ul style="list-style-type: none"> Analog input 0 to +10 V $\overline{\text{DC}}$ (max. safe voltage 24 V), impedance 30 kΩ or Analog input X - Y mA, X and Y being programmable from 0 to 20 mA, impedance 250 Ω Reaction time: 5 ms \pm 1 ms 11-bit resolution, accuracy \pm 0.6% for $\Delta\theta = 60^\circ\text{C}$ (140°F), linearity \pm 0.15% of max. value
COM	Analog I/O common	0 V
AO2 AO3	Depending on software configuration: Analog voltage outputs or Analog current outputs	<ul style="list-style-type: none"> 0 - 10 V $\overline{\text{DC}}$ or -10/+10 V $\overline{\text{DC}}$ bipolar analog output depending on software configuration, load impedance greater than 50 kΩ or Analog current output X-Y mA, X and Y being programmable from 0 to 20 mA, max. load impedance 500 Ω 10-bit resolution Reaction time 5 ms \pm 1 ms, accuracy \pm 1% for $\Delta\theta = 60^\circ\text{C}$ (140°F), linearity \pm 0.2%

Option terminals

Terminal	Function	Electrical characteristics									
+24	Logic input power supply	Switch SW4 in Source or Sink Int position <ul style="list-style-type: none"> +24 V \approx output (min. 21 V, max. 27 V), protected against short-circuits and overloads Max. current available for customers 200 mA (This current corresponds to the total consumption on the control card +24 and the option cards +24) Switch SW4 in Sink Ext position <ul style="list-style-type: none"> Input for external +24 V \approx power supply for the logic inputs 									
LI11 LI12 LI13 LI14	Programmable logic inputs	<ul style="list-style-type: none"> +24 V \approx (max. 30 V) Impedance 3.5 kΩ Reaction time: 5 ms \pm 1 ms <table border="1" style="margin-left: auto; margin-right: auto;"> <thead> <tr> <th>Switch SW4</th> <th>State 0</th> <th>State 1</th> </tr> </thead> <tbody> <tr> <td>Source (factory setting)</td> <td>< 5 V \approx</td> <td>> 11 V \approx</td> </tr> <tr> <td>Sink Int or Sink Ext</td> <td>> 16 V \approx</td> <td>< 10 V \approx</td> </tr> </tbody> </table>	Switch SW4	State 0	State 1	Source (factory setting)	< 5 V \approx	> 11 V \approx	Sink Int or Sink Ext	> 16 V \approx	< 10 V \approx
Switch SW4	State 0	State 1									
Source (factory setting)	< 5 V \approx	> 11 V \approx									
Sink Int or Sink Ext	> 16 V \approx	< 10 V \approx									
0V	Logic input common	0 V									

TH2 + TH2 -	PTC probe input	<ul style="list-style-type: none"> Trip threshold 3 kΩ, reset threshold 1.8 kΩ Short-circuit detection threshold < 50Ω
RP	Frequency input	<ul style="list-style-type: none"> Frequency range: 0...30 kHz Cyclic ratio: 50% \pm 10% Maximum sampling time: 5 ms \pm 1 ms Maximum input voltage 30 V, 15 mA Add a resistor if the input voltage is greater than 5 V (510 Ω for 12 V, 910 Ω for 15 V, 1.3 kΩ for 24 V) State 0 if < 1.2 V, state 1 if > 3.5 V
LO3 LO4	Open collector programmable logic outputs	<ul style="list-style-type: none"> +24 V \approx (max. 30 V) Max. current 20 mA for internal power supply and 200 mA for external power supply Reaction time 5 ms \pm 1 ms
CLO	Logic output common	
0V	0 V	0 V

Option terminals

Encoder interface card terminals

VW3 A3 401...407

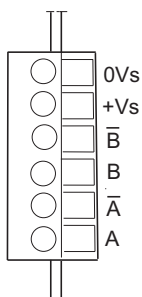

Maximum wire size:
1.5 mm² - AWG 16

Max. tightening torque:
0.25 Nm - 2.21 lb.in

Characteristics and functions of the terminals

Encoder interface cards with RS422-compatible differential outputs

Terminal	Function	Electrical characteristics	
		VW3 A3 401	VW3 A3 402
+Vs 0Vs	Encoder power supply	<ul style="list-style-type: none"> • 5 V \pm (max. 5.5 V) protected against short-circuits and overloads • Max. current 200 mA 	<ul style="list-style-type: none"> • 15 V \pm (max. 16 V) protected against short-circuits and overloads • Max. current 175 mA
A, /A B, /B	Incremental logic inputs	<ul style="list-style-type: none"> • Max. resolution: 5000 points/rev • Max. frequency: 300 kHz 	

Encoder interface cards with open collector outputs

Terminal	Function	Electrical characteristics	
		VW3 A3 403	VW3 A3 404
+Vs 0Vs	Encoder power supply	<ul style="list-style-type: none"> • 12 V \pm (max. 13 V) protected against short-circuits and overloads • Max. current 175 mA 	<ul style="list-style-type: none"> • 15 V \pm (max. 16 V) protected against short-circuits and overloads • Max. current 175 mA
A, /A B, /B	Incremental logic inputs	<ul style="list-style-type: none"> • Max. resolution: 5000 points/rev • Max. frequency: 300 kHz 	

Encoder interface cards with push-pull outputs

Terminal	Function	Electrical characteristics		
		VW3 A3 405	VW3 A3 406	VW3 A3 407
+Vs 0Vs	Encoder power supply	<ul style="list-style-type: none"> • 12 V \pm (max. 13 V) protected against short-circuits and overloads • Max. current 175 mA 	<ul style="list-style-type: none"> • 15 V \pm (max. 16 V) protected against short-circuits and overloads • Max. current 175 mA 	<ul style="list-style-type: none"> • 24 V \pm (min. 20 V, max. 30 V) protected against short-circuits and overloads • Max. current 100 mA
A, /A B, /B	Incremental logic inputs	<ul style="list-style-type: none"> • Max. resolution: 5000 points/rev • Max. frequency: 300 kHz 		

Option terminals

Selecting the encoder

The 7 encoder interface cards available as options with the ATV61 enable three different encoder technologies to be used:

- Optical incremental encoder with differential outputs compatible with the RS422 standard
- Optical incremental encoder with open collector outputs
- Optical incremental encoder with push-pull outputs

The encoder must comply with the following two limits:

- Maximum encoder frequency 300 kHz
- Maximum resolution 5000 points/revolution

Choose the maximum standard resolution within these limits to obtain optimum accuracy.

Wiring the encoder

Use a shielded cable containing 3 twisted pairs with a pitch of between 25 and 50 mm (0.98 in. and 1.97 in.). Connect the shielding to ground at both ends.

The minimum cross-section of the conductors must comply with the data in the table below, in order to limit line voltage drop:

Max. encoder cable length	VW3 A3 401...402			VW3 A3 403...407		
	Max. consumption current of encoder	Minimum cross-section of conductors		Max. consumption current of encoder	Minimum cross-section of conductors	
10 m 32.8 ft	100 mA	0.2 mm ²	AWG 24	100 mA	0.2 mm ²	AWG 24
	200 mA	0.2 mm ²	AWG 24	200 mA	0.2 mm ²	AWG 24
50 m 164 ft	100 mA	0.5 mm ²	AWG 20	100 mA	0.5 mm ²	AWG 20
	200 mA	0.75 mm ²	AWG 18	200 mA	0.75 mm ²	AWG 18
100 m 328 ft	100 mA	0.75 mm ²	AWG 18	100 mA	0.75 mm ²	AWG 18
	200 mA	1.5 mm ²	AWG 15	200 mA	1.5 mm ²	AWG 15
200 m 656 ft	-	-	-	100 mA	0.5 mm ²	AWG 20
	-	-	-	200 mA	1.5 mm ²	AWG 15
300 m 984 ft	-	-	-	100 mA	0.75 mm ²	AWG 18
	-	-	-	200 mA	1.5 mm ²	AWG 15

Connection diagrams

Connection diagrams conforming to standards EN 954-1 category 1 and IEC/EN 61508 capacity SIL1, stopping category 0 in accordance with standard IEC/EN 60204 1

Single-phase power supply (ATV61H 075M3 to U75M3)

Diagram with line contactor

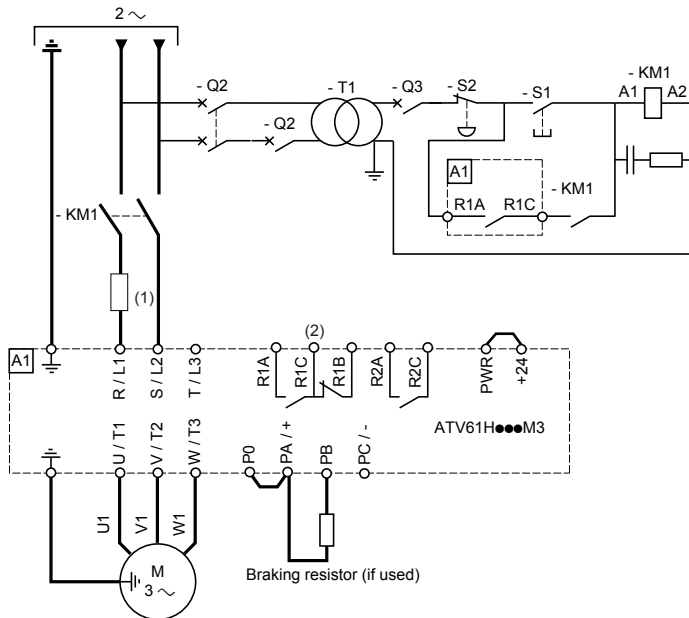
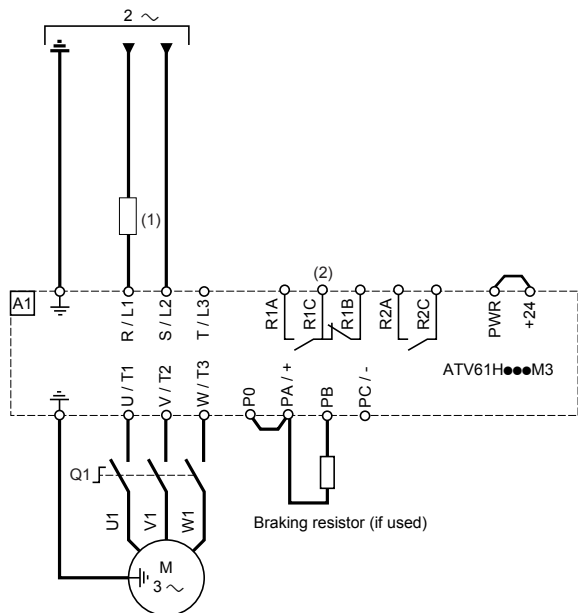



Diagram with switch disconnect



(1) Line choke, if used (compulsory for ATV61H U40M3 to U75M3 drives)

(2) Fault relay contacts for remote signaling of drive status

 Inhibit the input phase loss fault (IPL) so that ATV61H 075M3 to U75M3 drives can operate on a single-phase supply (see the Programming Manual). If this fault is set to its factory configuration, the drive will stay locked in fault mode.

Note: Install interference suppressors on all inductive circuits near the drive or connected to the same circuit (relays, contactors, solenoid valves, etc).

Choice of associated components:

Please refer to the catalog.

Connection diagrams

Connection diagrams conforming to standards EN 954-1 category 1 and IEC/EN 61508 capacity SIL1, stopping category 0 in accordance with standard IEC/EN 60204-1

Three-phase power supply

Diagram with line contactor

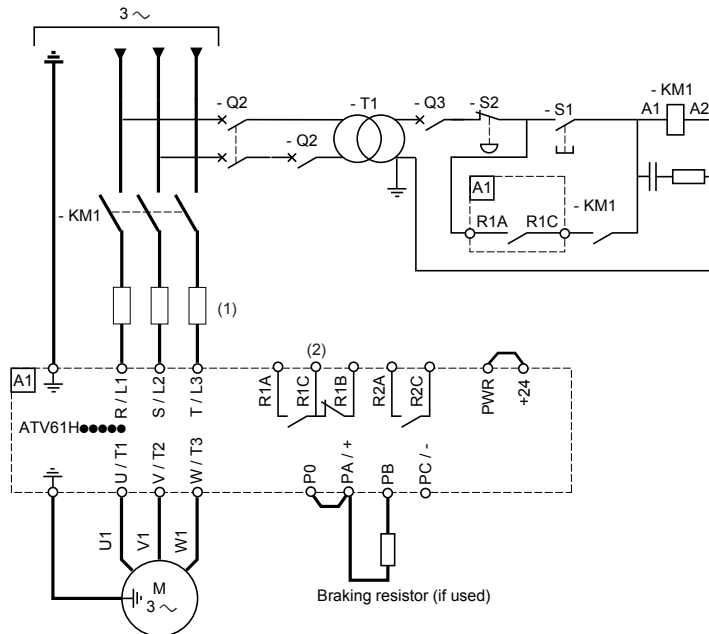
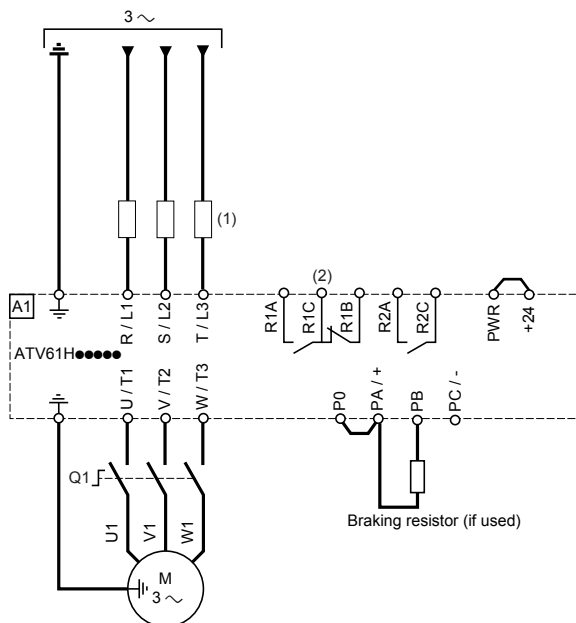

Diagram with switch disconnect



- (1) Line choke (if used)
- (2) Fault relay contacts for remote signaling of drive status

Note: Install interference suppressors on all inductive circuits near the drive or coupled to the same circuit (relays, contactors, solenoid valves, etc).

Choice of associated components:
Please refer to the catalog.

Connection diagrams

Connection diagrams conforming to standards EN 954-1 category 3 and IEC/EN 61508 capacity SIL2, stopping category 0 in accordance with standard IEC/EN 60204-1

This connection diagram is suitable for use with machines with a short freewheel stop time (machines with low inertia or high resistive torque).

When the stop request is activated, the motor power supply is cut immediately and it stops in accordance with category 0 of standard IEC/EN 60204-1.

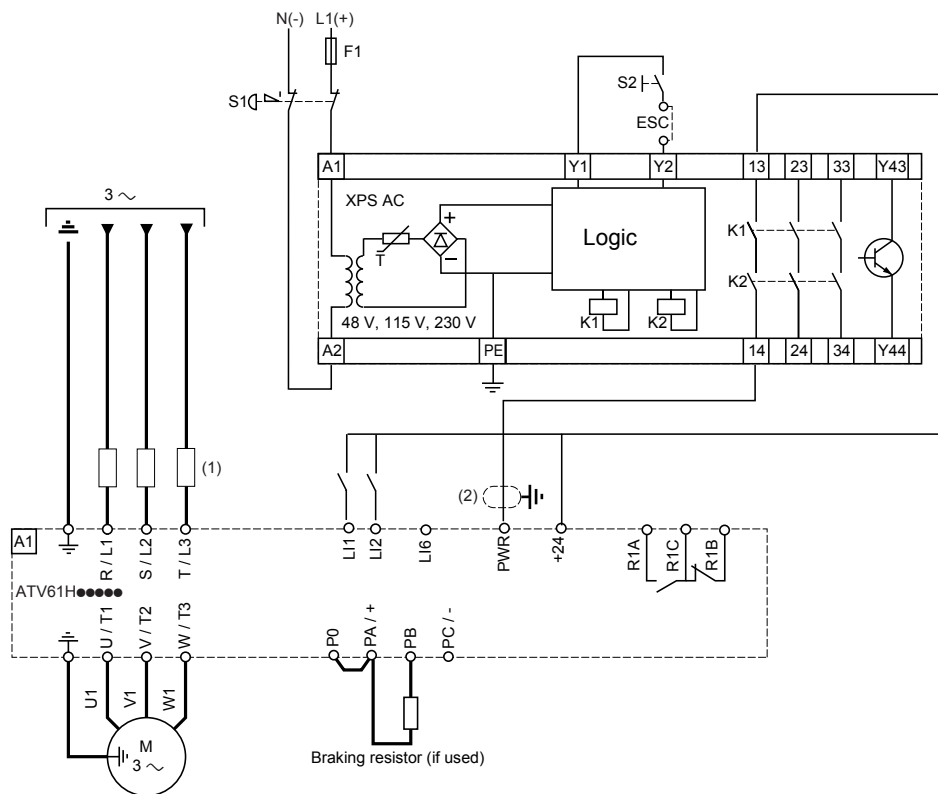

(1) Line choke (if used)

(2) It is essential to ground the shielding on the cable connected to the Power Removal input.

- Standard EN 954-1 category 3 requires the use of a dual-contact stop button (S1).
- S1 is used to activate the Power Removal safety function.
- S2 is used to initialize the Preventa module when powering up or after an emergency stop. ESC enables the use of other initialization conditions for the module.
- One Preventa module can be used for the Power Removal safety function on several ATV61 drives.
- A logic output on the Preventa module can be used to indicate reliably that the drive is operating in safe conditions.

Note:

For preventive maintenance, the Power Removal function must be activated at least once a year.

The drive power supply must be turned off and then on again before carrying out this preventive maintenance.

The drive logic output signals cannot be considered as safety-type signals.

Install interference suppressors on all inductive circuits near the drive or coupled to the same circuit (relays, contactors, solenoid valves, etc).

Choice of associated components:

Please refer to the catalog.

Connection diagrams

Connection diagram conforming to standards EN 954-1 category 3 and IEC/EN 61508 capacity SIL2, stopping category 1 in accordance with standard IEC/EN 60204-1

This connection diagram is suitable for use with machines with a long freewheel stop time (machines with high inertia or low resistive torque).

When the stop request is activated, deceleration of the motor, controlled by the drive, is requested first. Then, after a time delay corresponding to the deceleration time, the Power Removal safety function is activated.

Example:

- 2-wire control
- L11 assigned to forward
- L12 assigned to reverse

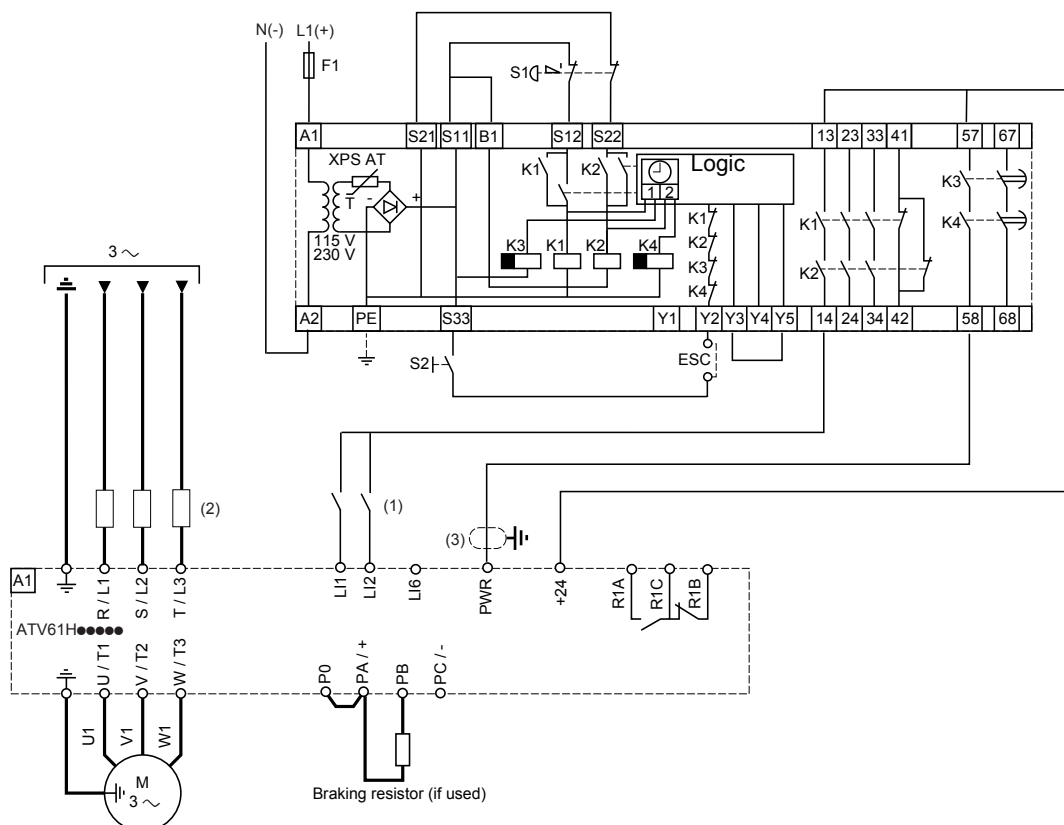

(1) In this example, the logic inputs L1● are wired as “Source” but can be wired as “Sink Int” or “Sink Ext”.

(2) Line choke (if used)

(3) It is essential to ground the shielding on the cable connected to the Power Removal input.

- Standard EN 954-1 category 3 requires the use of a dual-contact stop button (S1).
- S1 is used to activate the Power Removal safety function.
- S2 is used to initialize the Preventa module when powering up or after an emergency stop. ESC enables the use of other initialization conditions for the module.
- One Preventa module can be used for the Power Removal safety function on several ATV61 drives. In this case the time delay must be set to the longest stopping time.
- A logic output on the Preventa module can be used to indicate reliably that the drive is operating in safe conditions.

Note:

For preventive maintenance, the Power Removal function must be activated at least once a year.

The drive power supply must be turned off and then on again before carrying out this preventive maintenance.

The drive logic output signals cannot be considered as safety-type signals.

Install interference suppressors on all inductive circuits near the drive or coupled to the same circuit (relays, contactors, solenoid valves, etc).

Choice of associated components:

Please refer to the catalog.

Connection diagrams

Control connection diagrams

Control card connection diagram

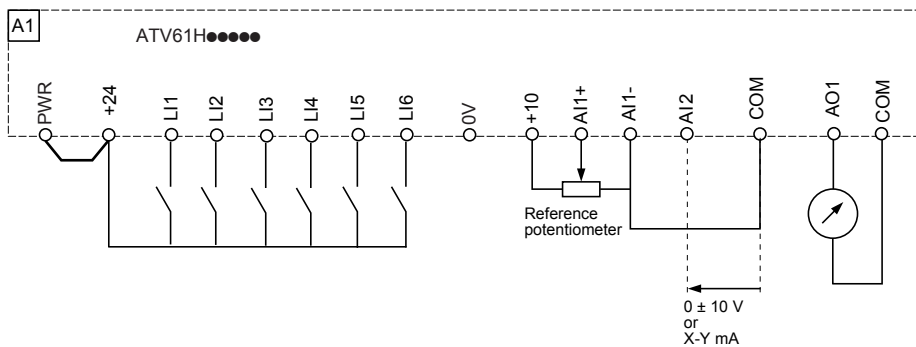

Logic input switch (SW1)

The logic input switch (SW1) is used to adapt the operation of the logic inputs to the technology of the programmable controller outputs.

- Set the switch to Source (factory setting) if using PLC outputs with PNP transistors.
- Set the switch to Sink Int or Sink Ext if using PLC outputs with NPN transistors.

- Switch SW1 set to "Source" position

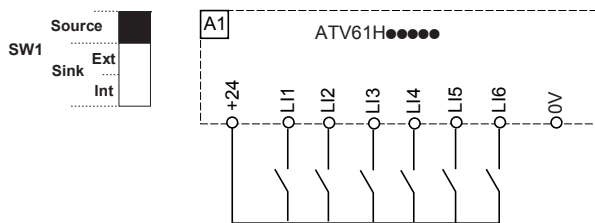

- Switch SW1 set to "Source" position and use of an external power supply for the LIs

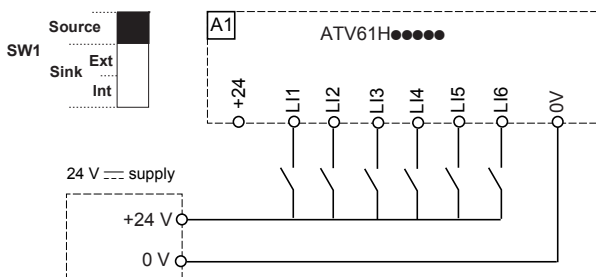

- Switch SW1 set to "Sink Int" position

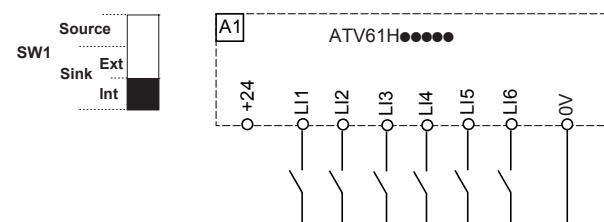

- Switch SW1 set to "Sink Ext" position

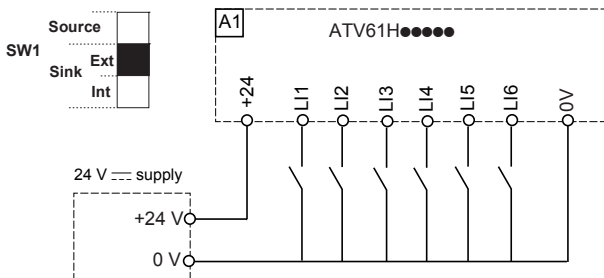

⚠ WARNING

UNINTENDED EQUIPMENT OPERATION

When switch SW1 is set to "Sink Int" or "Sink Ext", the common must never be connected to ground or the protective ground, as there is then a risk of unintended equipment operation on the first insulation fault.

Failure to follow this instruction can result in death, serious injury or equipment damage.

Connection diagrams

Bipolar speed reference

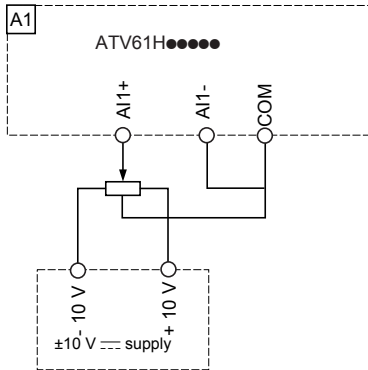

Speed reference using axis control

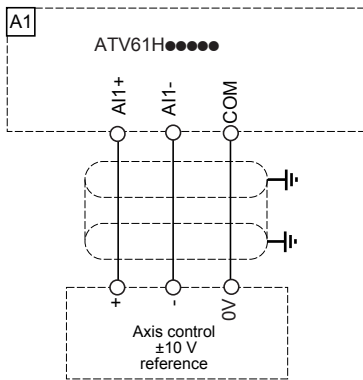

Switch SW2

The LI6 logic input switch (SW2) makes it possible to use the LI6 input:

- Either as a logic input by setting the switch to LI (factory setting)
- Or for motor protection via PTC probes by setting the switch to PTC

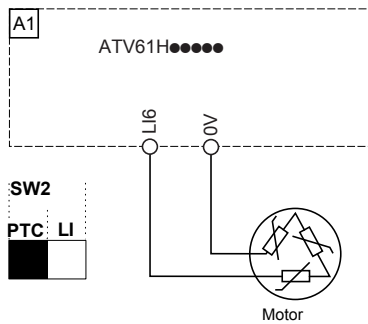

Control power supply via an external source

The control card can be supplied via an external +24 V DC supply source

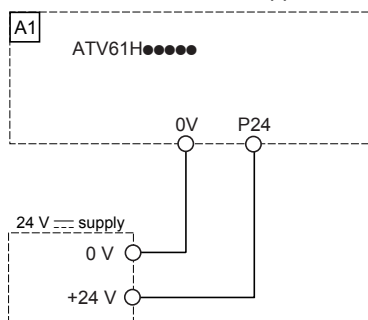

Connection diagrams

I/O extension card connection diagrams

Connection diagram for extended I/O option card (VW3 A3 202)

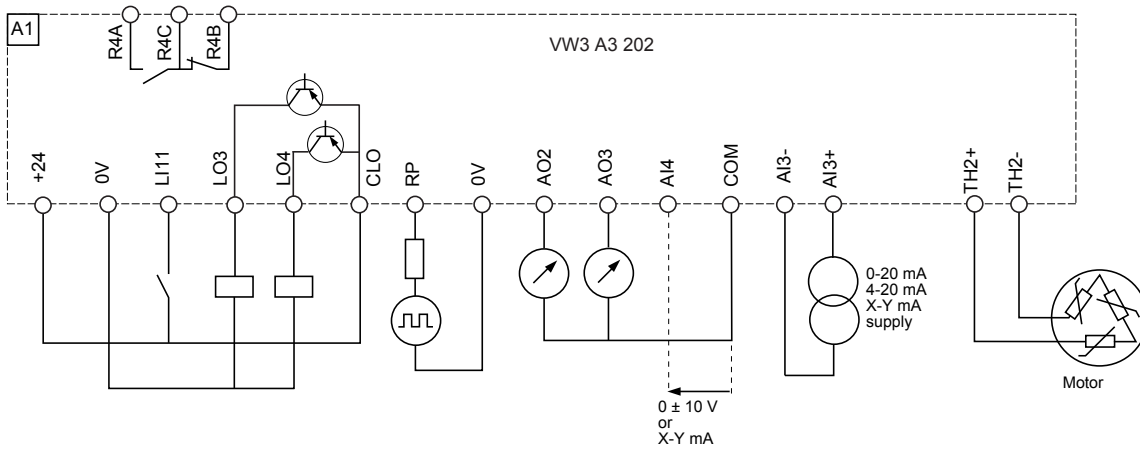

Connection diagram for logic I/O option card (VW3 A3 201)

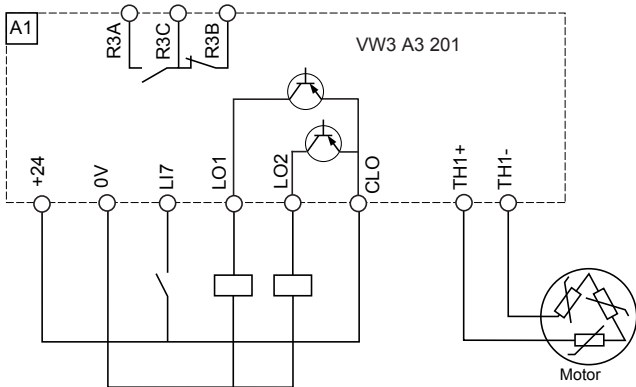

Connection diagrams

SW3/SW4 logic I/O switch

- Switch in “Source” position

SW3 or SW4

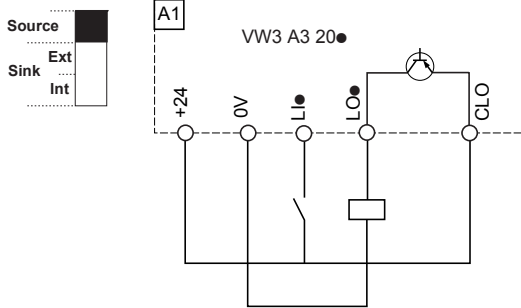

- Switch in “Source” position and use of an external +24 V_{DC} supply source

SW3 or SW4

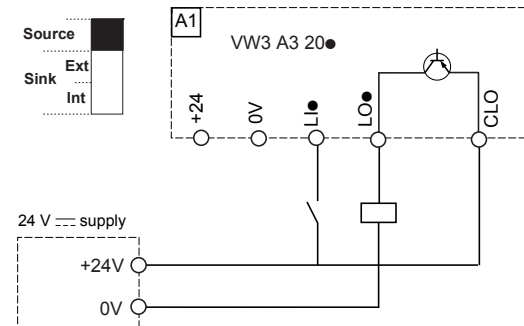

- Switch in “Sink Int” position

SW3 or SW4

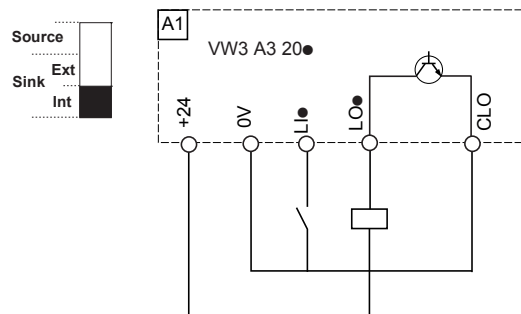

- Switch in “Sink Ext” position

SW3 or SW4

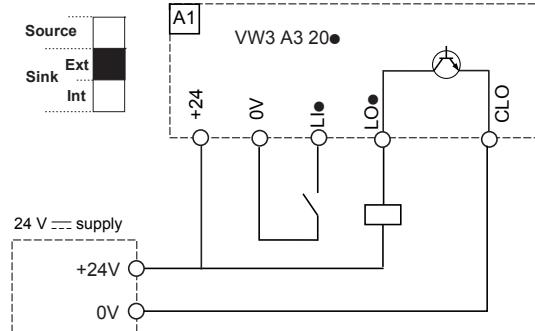

WARNING

UNINTENDED EQUIPMENT OPERATION

When switches SW3 or SW4 are set to “Sink Int” or “Sink Ext”, the common must never be connected to ground or the protective ground, as there is then a risk of unintended equipment operation on the first insulation fault.

Failure to follow this instruction can result in death, serious injury or equipment damage.

Connection diagrams

Connection of several drives in parallel on the DC bus

Connection in parallel on the DC bus is recommended in applications for which full motor power must be guaranteed.

Each drive uses its own charging circuit

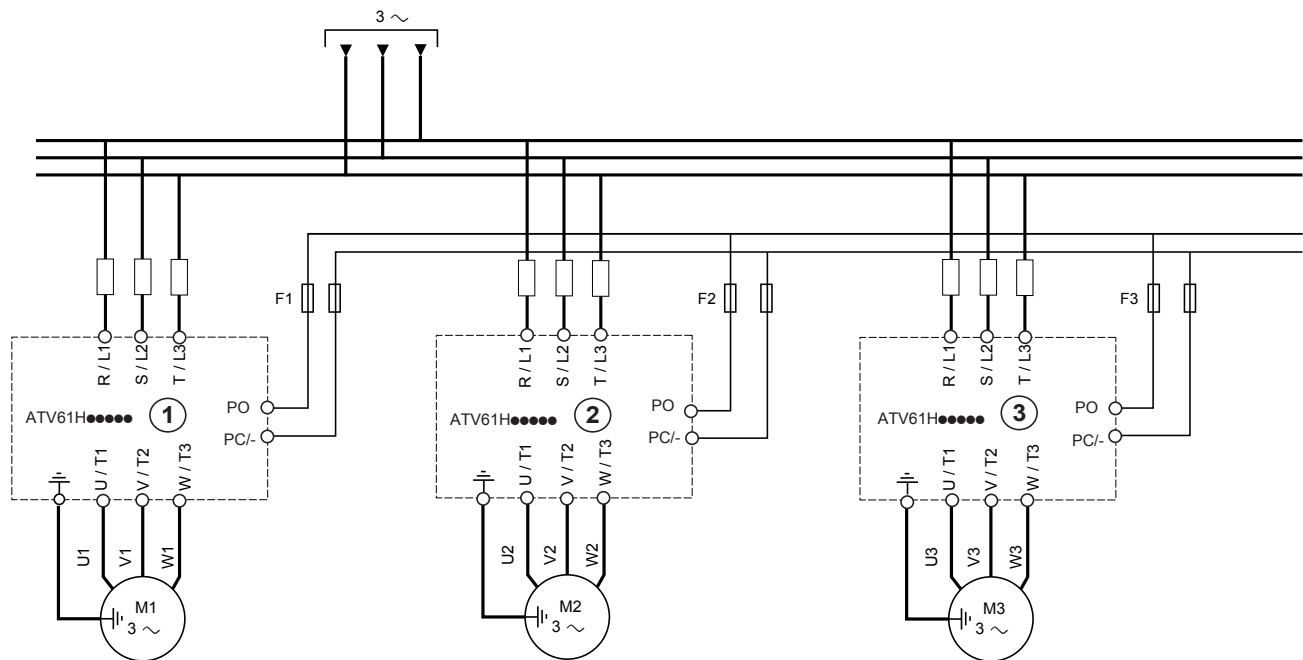

Drives ①, ② and ③ must not be more than one size apart when they are connected in this way.

F1, F2, F3: Fast-acting semiconductor fuses for protection on the DC bus side.

Use on IT system and “corner grounded” system

IT system: Isolated or impedance grounded neutral

Use a permanent insulation monitor compatible with non-linear loads, such as a Merlin Gerin type XM200 or equivalent.

“Corner grounded” system: System with one phase connected to ground

Altivar 61 drives feature built-in RFI filters. When using ATV61H U30Y to D90Y drives on an IT system, the link between these filters and ground must be removed as shown in the following two diagrams. For other catalog numbers, removal of this link is possible but not mandatory:

Remove the jumper located to the left of the power terminals (two jumpers for ATV61 ●D22N4).

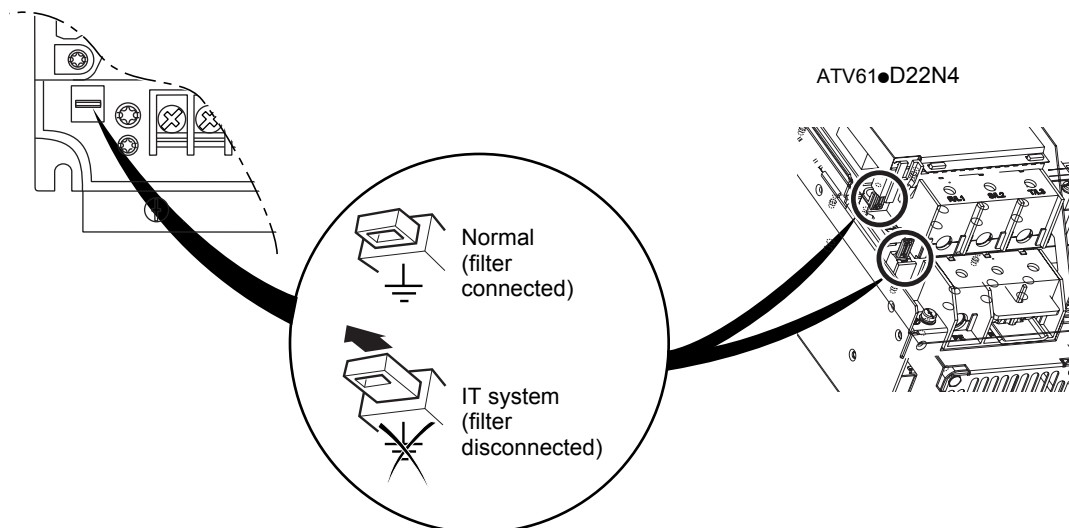

⚠ CAUTION

RISK OF DAMAGE TO THE DRIVE

On ATV61●075N4 to U40N4 ratings, if the filters are disconnected, the drive's switching frequency must not exceed 4 kHz. Refer to the Programming Manual for the corresponding parameter setting.

Failure to follow these instructions can result in injury and/or equipment damage.

Use on IT system and “corner grounded” system

Disconnection of the filter on ATV61H D37Y to D90Y products

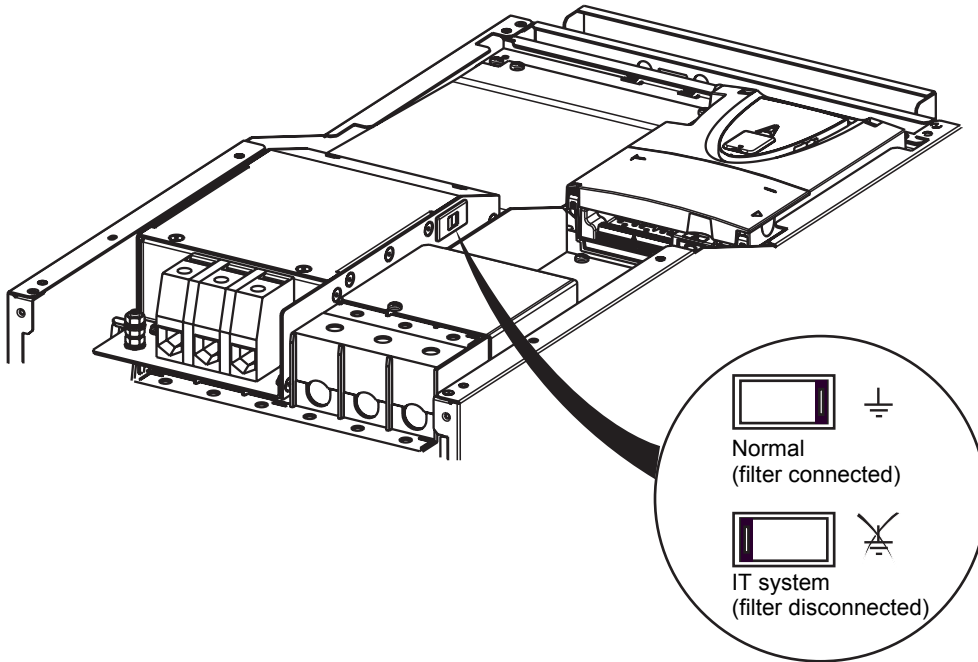

WARNING

RISK OF ELECTRIC SHOCK

- ATV61H U30Y to D90Y drives must not be connected to a “corner grounded” system.
- ATV61H●●●S6X must not be used with corner grounded systems in case of altitude is higher than 2000m.

Failure to follow this instruction can result in death, serious injury or equipment damage.

Electromagnetic compatibility, wiring

Electromagnetic compatibility

Principle

- Grounds between drive, motor and cable shielding must have “high-frequency” equipotentiality.
- Use of shielded cables with shielding connected to ground at both ends for the motor cables, braking resistor (if used) and control-signal wiring. Metal ducting or conduit can be used for part of the shielding length provided that there is no break in continuity.
- Ensure maximum separation between the power supply cable (line supply) and the motor cable.

Installation diagram

ATV61H 075M3 to D15M3X, ATV61H 075N4 to D18N4 and ATV61H U22S6X to U75S6X

- Attach and ground the shielding of cables **4** and **5** as close as possible to the drive:
 - Strip the shielding.
 - Use stainless steel metal clamps on the parts from which the shielding has been stripped, to attach them to the metal plate **2**. The shielding must be clamped tightly enough to the metal plate to ensure correct contact.
- Install the control EMC plate **11** on the sheet steel grounded plate **2**, as shown in the diagram.
- Attach and ground the shielding of cables **7**, **12** and **13** as close as possible to the drive:
 - Strip the shielding.
 - Use stainless steel metal clamps on the parts from which the shielding has been stripped, to attach them to the control EMC flange **9**. The shielding must be clamped tightly enough to the metal plate to ensure correct contact.

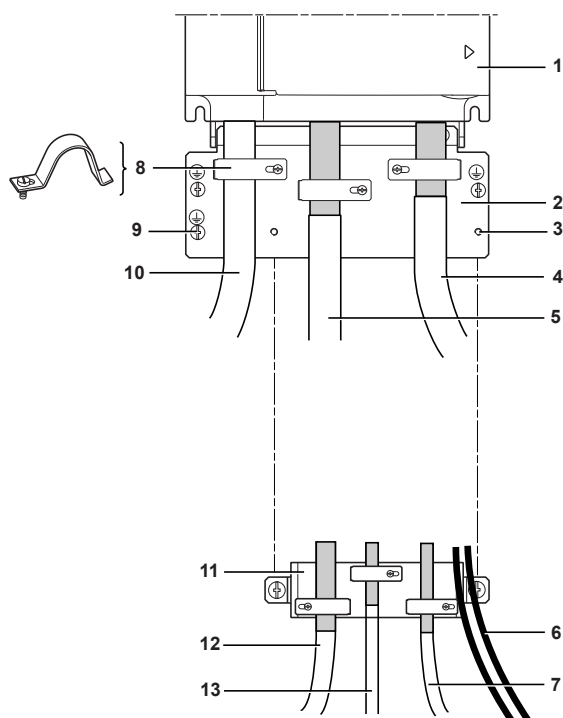

1 Altivar 61

2 Sheet steel grounded plate supplied with the drive

3 Tapped holes for installing the control EMC plate

4 Shielded cable for motor connection, with shielding connected to ground at both ends. The shielding must be continuous and intermediate terminals must be in EMC shielded metal boxes.

5 Shielded cable for connecting the braking resistor (if used). The shielding must be continuous and intermediate terminals must be in EMC shielded metal boxes.

6 Non-shielded wires for relay contact output

7 Shielded cables for connecting the Power Removal safety function input. The shielding must be continuous and intermediate terminals must be in EMC shielded metal boxes.

8 Metal clamps

9 Protective ground connection

10 Unshielded power supply cable or wires

11 Control EMC plate

12 Shielded cables for connecting the control-signal section. For applications requiring several conductors, use cables with a small cross-section (0.5 mm² - AWG 20).

13 Shielded cables for connecting the encoder. The shielding must be continuous and intermediate terminals must be in EMC shielded metal boxes.

Note:

- If using an additional input filter, it should be installed under the drive and connected directly to the line supply via an unshielded cable. Link **10** on the drive is then established via the filter output cable.
- The HF equipotential ground connection between the drive, motor and cable shielding does not remove the need to connect the PE protective conductors (green-yellow) to the appropriate terminals on each unit.

Electromagnetic compatibility, wiring

Installation diagram

ATV61H D18M3X to D45M3X, ATV61H D22N4 to D75N4 and ATV61H U30Y to D90Y

Attach and ground the shielding of cables **4** and **5** as close as possible to the drive:

- Strip the shielding.
- Use stainless steel metal clamps on the parts from which the shielding has been stripped, to attach them to the metal plate **2**. The shielding must be clamped tightly enough to the metal plate to ensure correct contact.

- Attach and ground the shielding of cables **6**, **7** and **8** as close as possible to the drive:
 - Strip the shielding.
 - Use stainless steel metal clamps on the parts from which the shielding has been stripped, to attach them to the drive. The shielding must be clamped tightly enough to the metal plate to ensure correct contact.

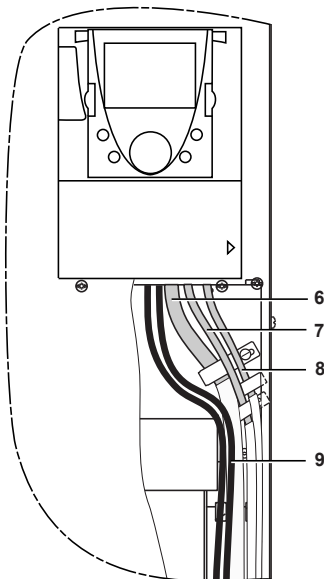
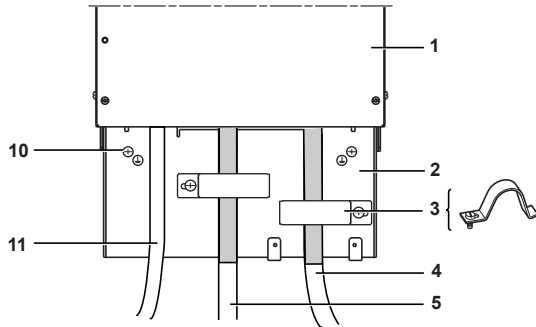

1 Altivar 61

2 Sheet steel grounded plate supplied with the drive

3 Metal clamps

4 Shielded cable for motor connection, with shielding connected to ground at both ends. The shielding must be continuous and intermediate terminals must be in EMC shielded metal boxes.

5 Shielded cable for connecting the braking resistor (if used). The shielding must be continuous and intermediate terminals must be in EMC shielded metal boxes.

6 Shielded cables for connecting the control-signal section. For applications requiring several conductors, use cables with a small cross-section (0.5 mm^2 - AWG 20).

7 Shielded cables for connecting the Power Removal safety function input. The shielding must be continuous and intermediate terminals must be in EMC shielded metal boxes.

8 Shielded cables for connecting the encoder. The shielding must be continuous and intermediate terminals must be in EMC shielded metal boxes.

9 Non-shielded wires for relay contact output

10 Protective ground connection

11 Unshielded power supply cable or wires

Note:

- If using an additional input filter, it should be installed under the drive and connected directly to the line supply via an unshielded cable. Link **4** on the drive is then established via the filter output cable.
- The HF equipotential ground connection between the drive, motor and cable shielding does not remove the need to connect the PE protective conductors (green-yellow) to the appropriate terminals on each unit.

