

Right choice for ultimate yield

LSIS strives to maximize customers' profit in gratitude of choosing us for your partner.

SV-iS7 User Manual

0.75–22kW [200V] 0.75–160kW [400V]



Safety Instructions



- Read this manual carefully before installing, wiring, operating, servicing or inspecting this equipment.
- Keep this manual within easy reach for quick reference.

LS Industrial Systems

Thank you for purchasing LS Variable Frequency Drives!

SAFETY INSTRUCTIONS

To prevent injury and property damage, follow these instructions. Incorrect operation due to ignoring instructions will cause harm or damage. The seriousness of which is indicated by the following symbols.

 DANGER	This symbol indicates the instant death or serious injury if you don't follow
 WARNING	This symbol indicates the possibility of death or serious injury
 CAUTION	This symbol indicates the possibility of injury or damage to property

- The meaning of each symbol in this manual and on your equipment is as follows.

 This is the safety alert symbol.
Read and follow instructions carefully to avoid dangerous situation.

 This symbol alerts the user to the presence of “dangerous voltage”
inside the product that might cause harm or electric shock.

- After reading this manual, keep it in the place that the user always can contact easily.
- This manual should be given to the person who actually uses the products and is responsible for their maintenance.

 **WARNING**

- **Do not remove the cover while power is applied or the unit is in operation.**
Otherwise, electric shock could occur.
- **Do not run the inverter with the front cover removed.**
Otherwise, you may get an electric shock due to high voltage terminals or charged capacitor exposure.
- **Do not remove the cover except for periodic inspections or wiring, even if the input power is not applied.**
Otherwise, you may access the charged circuits and get an electric shock.
- **Wiring and periodic inspections should be performed at least 10 minutes after disconnecting the input power and after checking the DC link voltage is discharged with a meter (below DC 30V).**
Otherwise, you may get an electric shock.
- **Operate the switches with dry hands.**
Otherwise, you may get an electric shock.
- **Do not use the cable when its insulating tube is damaged.**
Otherwise, you may get an electric shock.
- **Do not subject the cables to scratches, excessive stress, heavy loads or pinching.**
Otherwise, you may get an electric shock.

 **CAUTION**

- **Install the inverter on a non-flammable surface. Do not place flammable material nearby.**
Otherwise, fire could occur.
- **Disconnect the input power if the inverter gets damaged.**
Otherwise, it could result in a secondary accident and fire.

- **Do not touch the inverter while the input power is applied or after removed. It will remain hot for a couple of minutes.**
Otherwise, you may get bodily injuries such as skin-burn or damage.
- **Do not apply power to a damaged inverter or to an inverter with parts missing even if the installation is complete.**
Otherwise, electric shock could occur.
- **Do not allow lint, paper, wood chips, dust, metallic chips or other foreign matter into the drive.**
Otherwise, fire or accident could occur.

OPERATING PRECAUTIONS

(1) Handling and installation

- Handle according to the weight of the product.
- Do not stack the inverter boxes higher than the number recommended.
- Install according to instructions specified in this manual.
- Do not open the cover during delivery.
- Do not place heavy items on the inverter.
- Check the inverter mounting orientation is correct.
- Do not drop the inverter, or subject it to impact.
- Use the ground impedance of 100ohm or less for 200 V Class and 10ohm or less for 400V class.
- Take protective measures against ESD (Electrostatic Discharge) before touching the PCB for inspection or installation.
- Use the inverter under the following environmental conditions:

Environment	Ambient temp.	CT Load: - 10 ~ 50°C (non-freezing) VT Load: -10 ~ 40°C (non-freezing) Note: Use below 80% of load when used under VT Load at 50°C
	Relative humidity	90% RH or less (non-condensing)
	Storage temp.	- 20 ~ 65 °C
	Location	Protected from corrosive gas, combustible gas, oil mist or dust
	Altitude, Vibration	Max. 1,000m above sea level, Max. 5.9m/sec ² (0.6G) or less
	Atmospheric pressure	70 ~ 106 kPa

(2) Wiring

- Do not connect a power factor correction capacitor, surge suppressor, or RFI filter to the output of the inverter.
- The connection orientation of the output cables U, V, W to the motor will affect the direction of rotation of the motor.
- Incorrect terminal wiring could result in the equipment damage.
- Reversing connection of the input/output terminals(R,S,T / U,V,W) could damage the inverter.
- Only authorized personnel familiar with LS inverter should perform wiring and inspections.
- Always install the inverter before wiring. Otherwise, you may get an electric shock or have bodily injury.

(3) Trial run

- Check all parameters during operation. Changing parameter values might be required depending on the load.
- Always apply permissible range of voltage to the each terminal as indicated in this manual. Otherwise, it could lead to inverter damage.

(4) Operation precautions

- When the Auto restart function is selected, stay away from the equipment as a motor will restart suddenly after an alarm stop.
- The Stop key on the keypad is valid only when the appropriate function setting has been made. Prepare an emergency stop switch separately.
- If an alarm reset is made with the reference signal present, a sudden start will occur. Check that the reference signal is turned off in advance. Otherwise an accident could occur.
- Do not modify or alter anything inside the inverter.
- Motor might not be protected by electronic thermal function of inverter.
- Do not use a magnetic contactor on the inverter input for frequent starting/stopping of the inverter.
- Use a noise filter to reduce the effect of electromagnetic interference. Otherwise nearby electronic equipment may be affected.
- In case of input voltage unbalance, install AC reactor. Power Factor capacitors and generators may become overheated and damaged due to potential high frequency noise transmitted from inverter.
- Use an insulation-rectified motor or take measures to suppress

the micro surge voltage when driving 400V class motor with inverter. A micro surge voltage attributable to wiring constant is generated at motor terminals, and may deteriorate insulation and damage motor.

- Before operating unit and prior to user programming, reset user parameters to default settings.
- Inverter can easily be set to high-speed operations, Verify capability of motor or machinery prior to operating unit.
- Stopping torque is not produced when using the DC-Break function. Install separate equipment when stopping torque is needed.

(5) Fault prevention precautions

- Provide a safety backup such as an emergency brake which will prevent the machine and equipment from hazardous conditions if the inverter fails.

(6) Maintenance, inspection and parts replacement

- Do not conduct a megger (insulation resistance) test on the control circuit of the inverter.
- Refer to Chapter 7 Checking and Troubleshooting (parts replacement).

(7) Disposal

- Handle the inverter as an industrial waste when disposing of it.

(8) General instructions

- Many of the diagrams and drawings in this instruction manual show the inverter without a circuit breaker, a cover or partially open. Never run the inverter like this. Always place the cover with circuit breakers and follow this instruction manual when operating the inverter.

Introduction to the Manual

- This manual describes the specifications, installation, operation, functions and maintenance of SV-iS7 series inverter and is for the users who have basic experience of using an inverter.
- It is recommended you read carefully this manual in order to use SV-iS7 series inverter properly and safely.
- The manual consists as follows.

Chapter	Title	Contents
1	Basics	Describes the precautions and basic items which should be learned before using the Inverter.
2	Specifications	The control specifications, ratings and types of the input and output.
3	Installation	Information on the use environment and installation method.
4	Wiring	Wiring information for the power supply and signal terminals.
5	How To Use Keypad	Descriptions on the display and operation keys on the main body of the Inverter.
6	Basic Functions	Descriptions on the basic functions including frequency setting and operation command.
7	Checking and Troubleshooting	Descriptions on the failures and anomalies which may occur during operation.
8	Table of Functions	Brief summarize of functions.

Chapter 1	Basics		
1.1	What You Should Know before Use	-----	1-1
1.1.1	Check of product	-----	1-1
1.1.2	Parts	-----	1-1
1.1.3	Preparation of device and Parts for operation	-----	1-1
1.1.4	Installation	-----	1-1
1.1.5	Distribution	-----	1-2
1.2	Names and Uses of Parts	-----	1-2
1.2.1	End product (not more than 75 kW)	-----	1-2
1.2.2	When the front cover is removed (not more than 75kW)	-----	1-2
1.2.3	End product (more than 90kW)	-----	1-3
1.2.4	When the front cover is removed (more than 90kW)	-----	1-3
Chapter 2	Specifications		
2.1	Specifications	-----	2-1
2.1.1	Rated Input and Output : Input voltage of 200V class (0.75~22kW)	-----	2-1
2.1.2	Rated Input and Output : Input voltage of 200V class (30~75kW)	-----	2-1
2.1.3	Rated Input and Output : Input voltage of 400V class (0.75~22kW)	-----	2-2
2.1.4	Rated Input and Output : Input voltage of 400V class (30~160kW)	-----	2-2
2.1.5	Other commons	-----	2-3

Chapter 3	Installation		
3.1	Installation	-----	3-1
3.1.1	Cautions before installation	-----	3-1
3.1.2	Exterior and Dimension (UL Enclosed Type 1, IP21 Type)	-----	3-3
3.1.3	External dimension (UL Enclosed Type12, IP54 Type)	-----	3-14
3.1.4	Dimension and Weight of frame (UL Enclosed Type 1, IP21 Type)	-----	3-18
3.1.5	Dimension and Weight of Frame (UL Enclosed Type 12, IP54 Type)	-----	3-19
3.1.6	Installation Guide (UL Enclosed Type12, IP54 Type)	-----	3-20
Chapter 4	Wiring		
4.1	Wiring	-----	4-1
4.1.1	How to separate front cover when wiring (below 75kW)	-----	4-1
4.1.2	How to separate front cover when wiring (90~160 kW)	-----	4-3
4.1.3	Built-in EMC Filter	-----	4-4
4.1.4	Wiring precaution	-----	4-6
4.1.5	Grounding	-----	4-6
4.1.6	Terminal wiring diagram (Power terminal block)	-----	4-7
4.1.7	Terminals of main circuit	-----	4-8
4.1.8	Specifications of power terminal block and Exterior fuse	-----	4-10
4.1.9	Control terminal line diagram (Basic I/O terminal block)	-----	4-12

4.1.10	Control terminal line diagram (Insulated I/O terminal block)	-----	4-15	
4.1.11	Control circuit terminal	-----	4-16	
4.1.12	Specifications of signal terminal block distribution	-----	4-17	
4.2	Operation Checking	-----	4-18	1
4.2.1	Easy start	-----	4-18	
4.2.2	Easy start operation	-----	4-18	2
4.2.3	Checking for normal working	-----	4-19	
Chapter 5	How To Use Keypad			3
5.1	How To Use Keypad	-----	5-1	
5.1.1	Standard KEYPAD appearance and description (Graphic keypad)	-----	5-1	4
5.1.2	Menu composition	-----	5-6	5
5.1.3	Mode shift	-----	5-9	
5.1.4	Group shift	-----	5-9	
5.1.5	Code (Function item) shift	-----	5-10	6
5.1.6	Parameter setting	-----	5-11	
5.1.7	Operating status monitoring	-----	5-13	7
5.1.8	Failure status monitoring	-----	5-15	
5.1.9	How to initialize parameter	-----	5-17	8
Chapter 6	Basic Functions			
6.1	Basic Functions	-----	6-1	
6.1.1	How to set frequency	-----	6-1	
6.1.2	Analog command frequency fixation	-----	6-10	
6.1.3	Changing frequency to revolution	-----	6-11	
6.1.4	Sequential frequency setting	-----	6-11	
6.1.5	Operating command setting method	-----	6-12	

6.1.6	Prevention of forward or reverse rotation: Run Prevent	-----	6-14
6.1.7	Run Immediately with power on: Power-on Run	-----	6-14
6.1.8	Setting of accelerating/decelerating time and pattern	-----	6-15
6.1.9	Motor output voltage adjustment	-----	6-17
Chapter 7	Checking and Troubleshooting		
7.1	Checking and troubleshooting	-----	7-1
7.1.1	Protective functions	-----	7-1
7.1.2	Alarm functions	-----	7-4
7.1.3	Troubleshooting	-----	7-5
7.1.4	Replacement of cooling fan	-----	7-7
7.1.5	Daily and regular checkup list	-----	7-9
Chapter 8	Table of Functions		
8.1	Table of Functions	-----	8-1
8.1.1	Parameter mode – DRV group (→DRV)	-----	8-1
8.1.2	Parameter mode – Basic function group (→BAS)	-----	8-3
8.1.3	Parameter mode – Extended function group (PAR→ADV)	-----	8-6
8.1.4	Parameter mode – Control function group (→CON)	-----	8-10
8.1.5	Parameter mode – Input terminal block function group (→IN)	-----	8-15
8.1.6	Parameter mode – Output terminal block function group (→OUT)	-----	8-19

8.1.7	Parameter mode – Communication function group (→COM)	-----	8-23
8.1.8	Parameter mode – Applied function group (→APP)	-----	8-26
8.1.9	Parameter mode – Auto sequence operation group (→AUT)	-----	8-29
8.1.10	Parameter mode – Option card function group (→APO)	-----	8-33
8.1.11	Parameter mode – Protective function group (→PRT)	-----	8-35
8.1.12	Parameter mode – 2nd motor function group (→M2)	-----	8-38
8.1.13	Trip mode (TRP Current (or Last-x))	-----	8-39
8.1.14	Config mode (CNF)	-----	8-39
8.1.15	User/Macro mode – →MC1	-----	8-42
8.1.16	User/Macro mode – Traverse operation function group (→MC2)	-----	8-43

1

2

3

4

5

6

7

8

1.1 What You Should Know before Use

1.1.1 Check of product

Take the inverter out of the box, check the rating shown on a side of the product body and whether the inverter type and rated output are exactly what you ordered. Check also whether the product has been damaged during delivery.

SV	008	iS7	-	2	N	O	F	D
L S Inverter	Capacity of Applied Motor	Series Name		Input Voltage	Keypad	UL	EMC	DCR
	0008	0.75 [kW]	Wide-Use Inverter	2: 3-Phase 200~230[V]	N: NON	O: OPEN	Blank: Non-EMC	Blank: Non-DCR
	0015	1.5 [kW]						
	0022	2.2 [kW]						
	0037	3.7 [kW]						
	0055	5.5 [kW]						
	0075	7.5 [kW]						
	0110	11 [kW]						
	0150	15 [kW]						
	0185	18.5 [kW]						
	0220	22 [kW]		4: 3-Phase 380~480[V]	S: GLCD (Graphic Loader)	E: Enclosed UL Type1 ^(note1)	F: EMC	D: DCR
	0300	30 [kW]						
	0370	37 [kW]						
	0450	45 [kW]						
	0550	55 [kW]						
0750	75 [kW]							
0900	90 [kW]							
1100	110 [kW]							
1320	132 [kW]							
1600	160 [kW]			P: Enclosed UL Type 12				

Note1) Enclosed UL Type 1 has the conduit option additionally at 0.75 through 75 kW products.

1.1.2 Parts

If you have any doubt about the product or found the product damaged, call our company's branch offices (see the back cover of the manual).

1.1.3 Preparation of device and Parts for operation

Preparation for operation might slightly vary. Prepare parts according to the use.

1.1.4 Installation

Make sure you install the product correctly considering the place, direction or surroundings in order to prevent decrease in the life and performance of the inverter.

1.1.5 Distribution

Connect the power supply, electric motor and operating signals (control signals) to the terminal block. If you fail to connect them correctly, the inverter and peripheral devices might be damaged.

1.2 Names and Uses of Parts

1.2.1 End product (less than 75 kW)

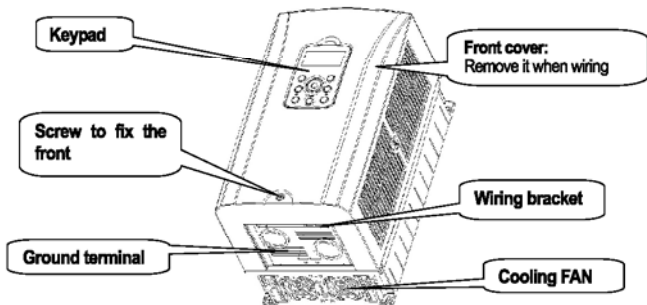

1.2.2 When the front cover is removed (less than 75 kW)

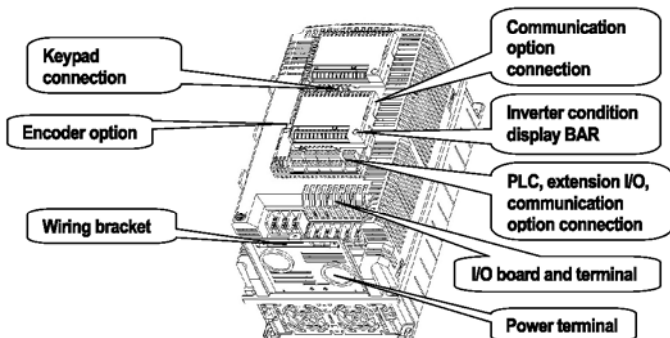

1.2.3 End Product (more than 90kW)

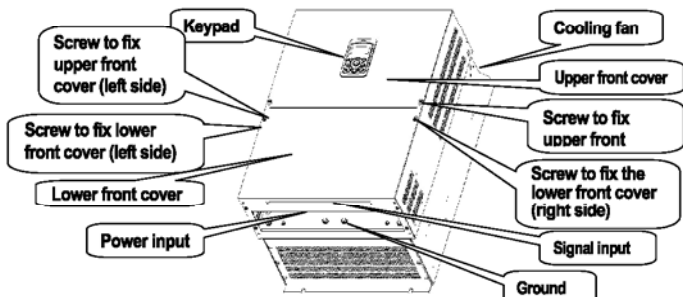

1.2.4 When the front cover is removed (more than 90kW)

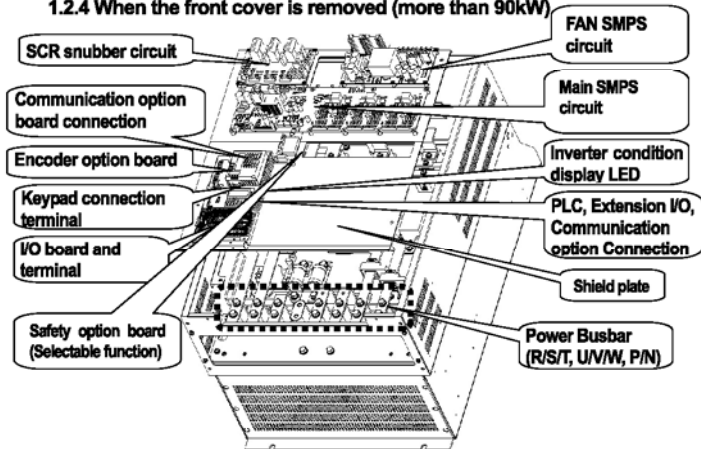

Remark

Please refer to option board manual for option board information.

M E M O

A large rectangular area with horizontal dashed lines, intended for writing a memo.

2.1 Specifications

2.1.1 Rated Input and Output : Input voltage of 200V class (0.75~22kW)

Type : SV xxx IS7 - 2x		0008	0015	0022	0037	0055	0075	0110	0150	0185	0220	
¹ Motor Applied	[HP]	1	2	3	5	7.5	10	15	20	25	30	
	[kW]	0.75	1.5	2.2	3.7	5.5	7.5	11	15	18.5	22	
Rated Output	² Rated Capacity [kVA]		1.9	3.0	4.5	6.1	9.1	12.2	17.5	22.9	28.2	33.5
	³ Rated Current [A]	CT	5	8	12	16	24	32	46	60	74	88
		VT	8	12	16	24	32	46	60	74	88	124
	Output Frequency		⁴ 0 ~ 400 [Hz] (Sensorless-1: 0 ~ 300Hz, Sensorless-2, Vector: 0 ~ 120Hz)									
Output Voltage [V]		⁵ 3-phase 200 ~ 230V										
Rated Input	Available Voltage [V]		3-phase 200 ~ 230 VAC (-15%, +10%)									
	Input Frequency		50 ~ 60 [Hz] (±5%)									
	Rated Current [A]	CT	4.3	6.9	11.2	14.9	22.1	28.6	44.3	55.9	70.8	85.3
		VT	6.8	10.6	14.9	21.3	28.6	41.2	54.7	69.7	82.9	116.1

* Non DCR products are provided warranty service when used in CT (Heavy duty) load rating only.

2.1.2 Rated Input and Output : Input voltage of 200V class (30~75kW)

Type : SV xxx IS7 - 2x		0300	0370	0450	0550	0750	-	-	-	-	-
¹ Motor Applied	[HP]	40	50	60	75	100	-	-	-	-	-
	[kW]	30	37	45	55	75	-	-	-	-	-
Rated Output	² Rated Capacity [kVA]		46	57	69	84	116	-	-	-	-
	³ Rated Current [A]	CT	116	146	180	220	288	-	-	-	-
		VT	146	180	220	288	345	-	-	-	-
	Output Frequency		⁴ 0 ~ 400 [Hz] (Sensorless-1: 0 ~ 300Hz, Sensorless-2, Vector: 0 ~ 120Hz)								
Output Voltage [V]		⁵ 3-phase 200 ~ 230V									
Rated Input	Available Voltage [V]		3-phase 200 ~ 230 VAC (-15%~+10%)								
	Input Frequency		50 ~ 60 [Hz] (±5%)								
	Rated Current [A]	CT	121	154	191	233	305	-	-	-	-
		VT	152	190	231	302	362	-	-	-	-

* Non DCR products are provided warranty service when used in CT (Heavy duty) load rating only.

2.1.3 Rated Input and Output : Input voltage of 400V class (0.75~22kW)

Type : SV xxx iS7 - 4x		0008	0015	0022	0037	0055	0075	0110	0150	0185	0220	
1) Motor Applied	[HP]	1	2	3	5	7.5	10	15	20	25	30	
	[kW]	0.75	1.5	2.2	3.7	5.5	7.5	11	15	18.5	22	
Rated Output	2) Rated Capacity [kVA]		1.9	3.0	4.5	6.1	9.1	12.2	18.3	22.9	29.7	34.3
	3) Rated Current [A]	CT	2.5	4	6	8	12	16	24	30	39	45
		VT	4	6	8	12	16	24	30	39	45	61
	Output Frequency		4) 0 ~ 400 [Hz] (Sensorless-1: 0 ~ 300Hz, Sensorless-2, Vector: 0 ~ 120Hz)									
	Output Voltage [V]		5) 3-phase 380 ~ 480V									
Rated Input	Available Voltage [V]		3-phase 380 ~ 480 VAC (-15%~+10%)									
	Input Frequency		50 ~ 60 [Hz] (±5%)									
	Rated Current [A]	CT	2.2	3.6	5.5	7.5	11.0	14.4	22.0	26.6	35.6	41.6
VT		3.7	5.7	7.7	11.1	14.7	21.9	26.4	35.5	41.1	55.7	

* Non DCR products are provided warranty service when used in CT (Heavy duty) load rating only.

2.1.4 Rated Input and Output : Input voltage of 400V class (30~160kW)

Type : SV xxx iS7 - 4x		0300	0370	0450	0550	0750	0900	1100	1320	1600	-	
1) Motor Applied	[HP]	40	50	60	75	100	120	150	180	225	-	
	[kW]	30	37	45	55	75	90	110	132	160	-	
Rated Output	2) Rated Capacity [kVA]		46	57	69	84	116	139	170	201	248	-
	3) Rated Current [A]	CT	61	75	91	110	152	183	223	264	325	-
		VT	75	91	110	152	183	223	264	325	370	-
	Output Frequency		4) 0 ~ 400 [Hz] (Sensorless-1: 0~300Hz, Sensorless-2, Vector: 0~120Hz)									
	Output Voltage [V]		5) 3-phase 380 ~ 480V									
Rated Input	Available Voltage [V]		3-phase 380 ~ 480 VAC (-15%, +10%)									
	Input Frequency		50 ~ 60 [Hz] (±5%)									
	Rated Current [A]	CT	55.5	67.9	82.4	102.6	143.4	174.7	213.5	255.6	316.3	-
VT		67.5	81.7	101.8	143.6	173.4	212.9	254.2	315.3	359.3	-	

* Non DCR products are provided warranty service when used in CT (Heavy duty) load rating only.

- 1) Motor Applied indicates the maximum capacity applied to use of a standard 4 pole standard motor.
- 2) Rated capacity : the input capacity of a 200V class is based on 220V and that of a 400V class is based on 440V. The current rating is based on CT current.
- 3) The output of rated current is limited according to setting of the carrier frequency (CON-04).
- 4) In case of Sensorless-1, you can set the frequency at up to 300Hz by selecting 3, 4 as the control mode (DRV-09 Control Mode).
In case of Sensorless-2, you can set the frequency at up to 120Hz by selecting 3, 4 as the control mode (DRV-09 Control Mode).
- 5) The maximum output voltage does not go up over the supplied power voltage. You can select the output voltage as you want below the supplied power voltage.

2.1.5 Other commons

1) Control

Control Method	V/F control, V/F PG, slip compensation, sensorless vector-1, sensorless vector-2, vector control
Frequency Setting	Digital command : 0.01Hz
Resolving Power	Analog command : 0.06Hz (maximum frequency : 60Hz)
Frequency Degree	Digital command operation : 0.01% of the maximum frequency Analog command operation : 0.1% of the maximum frequency
V/F Pattern	Linear, double reduction, user V/F
Overload Capacity	CT current rating : 150% for 1 minute, VT current rating : 110% for 1 minute
Torque Boost	Manual torque boost, Automatic torque boost

* Non DCR products are provided warranty service when used in CT (Heavy duty) load rating only.

2) Operation

	Operating Method	Selectable among keypad/ terminal block/ communication operation	
	Frequency Setting	Analog : 0 ~ 10[V], -10 ~ 10[V], 0 ~ 20[mA] Digital : keypad	
	Operating Function	PID control, up-down operation, 3-wire operation, DC break, Frequency limit, Frequency jump, Second function, Slip compensation, Reverse rotation prevention, Auto restarting, Inverter By-pass, Auto tuning Flying Start, Energy buffering, Power breaking, Flux breaking, Leakage current reduction, MMC, Easy Start	
		NPN (Sink) / PNP (Source) selectable	
Input	Multi-function Terminal (8 points) P1 ~ P8¹⁾	Function: forward operation, reverse operation, reset, external trip, emergency stop, jog operation, sequential frequency-high/medium/low, multi - level acceleration and deceleration – high/medium/low, D.C. control during stop, selection of a second motor, frequency increase, frequency decrease, 3-wire operation, change to general operation during PID operation, Main inverter body operation during option operation, analog command frequency fixation, acceleration and deceleration stop selectable	
	Multi-function Open Collector Terminal	Failure output and inverter operation output	Below DC 24V 50mA
Multi-function Relay Terminal	Below (N.O., N.C.) AC250V 1A, Below DC 30V 1A		
Output	Analog Output	0 ~ 10 Vdc (below 20mA) : selectable from frequency, current, voltage, direct current voltage	

1) The Functions for Multi-function terminal available according to IN-65~75 parameter setting of IN Group.

3) Protective Function

Trip	Over voltage, Low voltage, Over current, Earth current detection, Inverter overheat, Motor overheating, Output imaging, Overload protection, Communication error, Frequency command loss, Hardware failure, Cooling fan failure, Pre-PID failure, No motor trip, External break trip, etc.
Alarm	Stall prevention, Overload, Light load, Encoder error, Fan failure, Keypad command loss, Speed command loss.
Instantaneous Interruption²⁾	Below CT class 15 msec (below VT class 8 msec) : Operation continues (within rated input voltage, rated output) Above CT class 15 msec (above VT class 8 msec) : Available automatic restarts

2) Operation at the CT (Heavy Duty) current rating

4) Structure and Use Environment

Cooling Method	Forced air blast cooling : 0.75~15kW (200/400V class), 22kW (400V class) Inhalation cooling : 22~75kW (200V class), 30~160kW (400V class)
Protection Structure	Below 75 kW : Open type (IP 21), UL enclosed type 1 (Option) 30~75kW 200V, Above 90kW : Open type (IP 00) The others (Below 22kW): Enclosed IP54 type, UL enclosed type 12
Surrounding Temperature	CT (Heavy Duty) load : - 10 ~ 50°C (without ice or frost) VT (Normal Duty) load : - 10~ 40°C (without ice or frost) (It is recommended that you use less than 80% load when you use VT load at 50°C.) IP54 product: -10~40 °C (without ice or frost)
Preservation Temperature	-20°C ~ 65°C
Surrounding Humidity	Below 90% RH of relative humidity (with no dew formation)
Altitude, Vibration	Below 1,000m, below 5.9m/sec ² (0.6G)
Environment	There should be no corrosive gas, flammable gas, oil mist or dust.

M E M O

A large rectangular area with horizontal dashed lines, intended for writing a memo.

3.1 Installation

3.1.1 Cautions before installation

Be careful so that the plastic parts of the inverter may not be damaged. Do not move the product holding the cover only. Do not install the product where there is vibration, a press or truck. Life of the inverter greatly influenced by the surrounding temperatures, make sure that the surrounding temperature does not exceed the permitted temperature (-10 ~ 50°C).



<Measurement Points of Surrounding Temperature>

Install the inverter on an inflammable surface because its temperature rises high during operation.

Sufficient space is required to prevent heat saturation because the inverter emits heat.

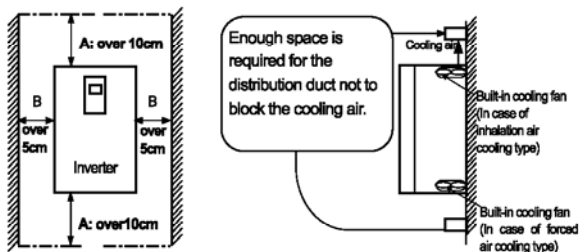

Remark

Over 50cm, B : over 20cm is necessary when you install an inverter above 30kW.

Caution

Avoid direct rays of light or a warm and humid place.

Install the inverter in a closed panel or clean place free from foreign substances such as oil mist and fiber dust.

If you install two or more inverters inside the panel, be careful about the location of the ventilation fan and inverter. See the figure below.

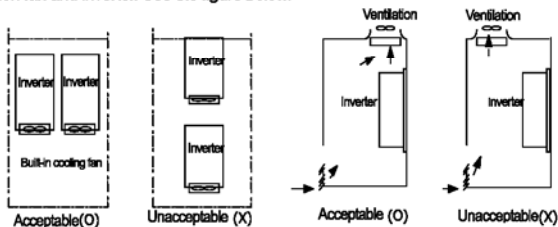

When two or more units are installed

Where the ventilation fan is installed

Install the inverter upright using screws or bolts so that the inverter does not move.

Note

Arrange the panels in order to the hot air generated by the heating of the inverter should be released.

3.1.2 Exterior and Dimension (UL Enclosed Type 1, IP21 Type)

1) SV0008-0037/IS7 (200V/400V)

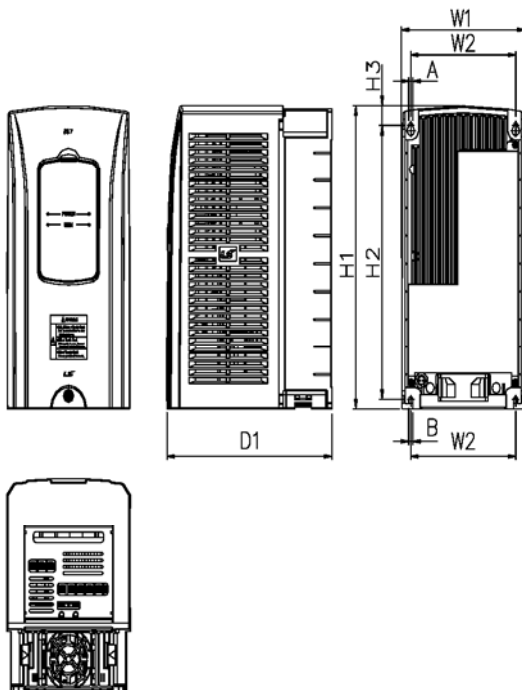

3

mm (inches)

Inverter capacity	W1	W2	H1	H2	H3	D1	A	B
SV0008-0037 IS7 - 2/4	150(5.90)	127(5.00)	284(11.18)	257 (10.11)	18(0.70)	200(7.87)	5(0.19)	5(0.19)

2) SV0055-0075iS7 (200V/400V)

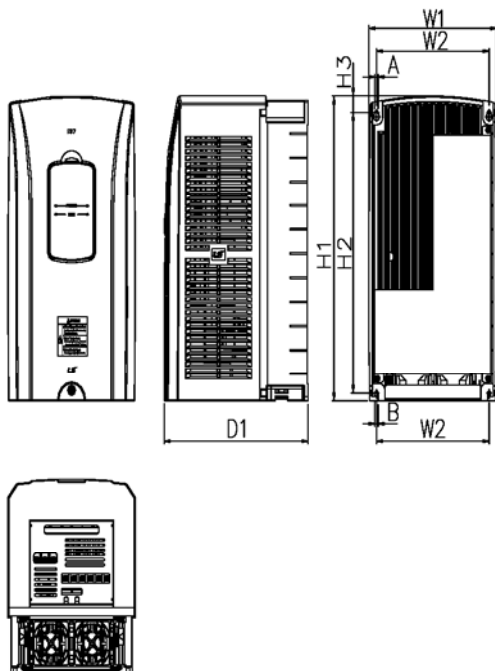

mm (inches)

Inverter capacity	W1	W2	H1	H2	H3	D1	A	B
SV0055-0075 iS7 - 2/4	200(7.87)	176(6.92)	355 (13.97)	327 (12.87)	19(0.74)	225(8.85)	5(0.19)	5(0.19)

3) SV0110-0150iS7 (200V/400V)

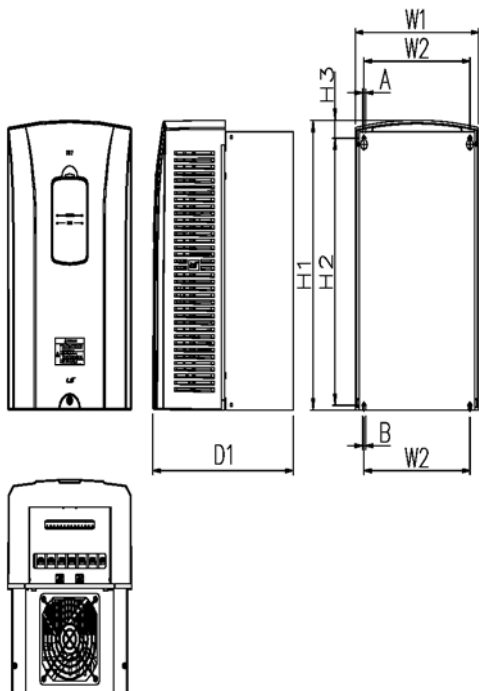

3

mm (inches)

Inverter capacity	W1	W2	H1	H2	H3	D1	A	B
SV0110-0150 iS7- 2/4	250(9.84)	214.6(8.44)	385(15.15)	355(13.97)	23.6(0.92)	284(11.18)	6.5(0.25)	6.5(0.25)

4) SV0185-0220iS7 (200V/400V)

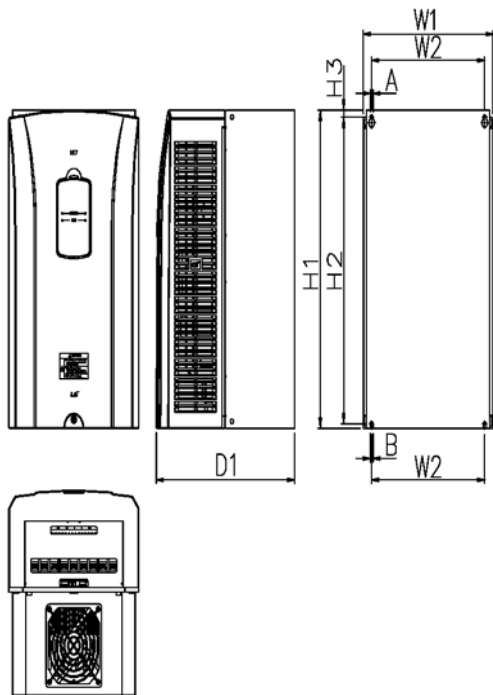

mm (inches)

Inverter capacity	W1	W2	H1	H2	H3	D1	A	B
SV0185-0220 iS7- 2/4	280(11.02)	243.5(9.58)	461.6(18.17)	445(17.51)	10.1(0.39)	298(11.73)	6.5(0.25)	6.5(0.25)

5) SV0300-iS7 (200V, IP00 Type)

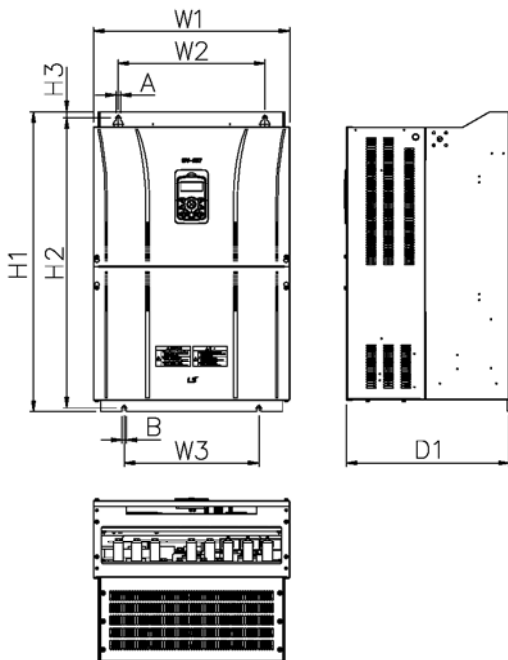

3

mm (inches)

Inverter capacity	W1	W2	H1	H2	H3	D1	A	B	W3
SV0300	300	190	570	552	10	265.2	10	10	190
iS7-2	(11.81)	(7.48)	(22.44)	(21.73)	(0.39)	(10.44)	(0.39)	(0.39)	(7.48)

6) SV0370-0450iS7 (200V, IP00 Type)

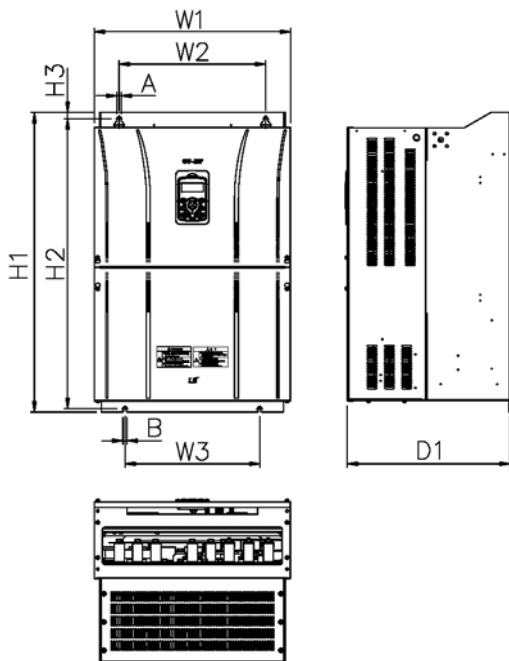

mm (inches)

Inverter capacity	W1	W2 / W3	H1	H2	H3	D1	A	B
SV0370~0450iS7-2	370 (14.56)	270 (10.63)	630 (24.8)	609 (23.97)	11 (0.43)	281.2 (11.07)	10 (0.39)	10 (0.39)

7) SV0300-0450iS7 (400V)

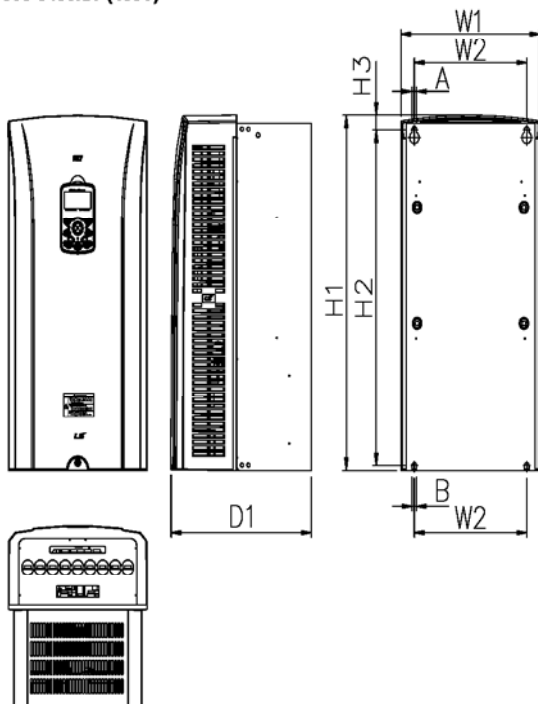

3

mm (inches)

Inverter capacity	W1	W2	H1	H2	H3	D1	A	B
SV300-450	300.1	242.8	594.1	562	24.1	303.2	10	10
iS7-4	(11.81)	(9.55)	(23.38)	(22.12)	(0.94)	(11.93)	(0.39)	(0.39)

8) SV0550-0750IS7 (200V, IP00 Type)

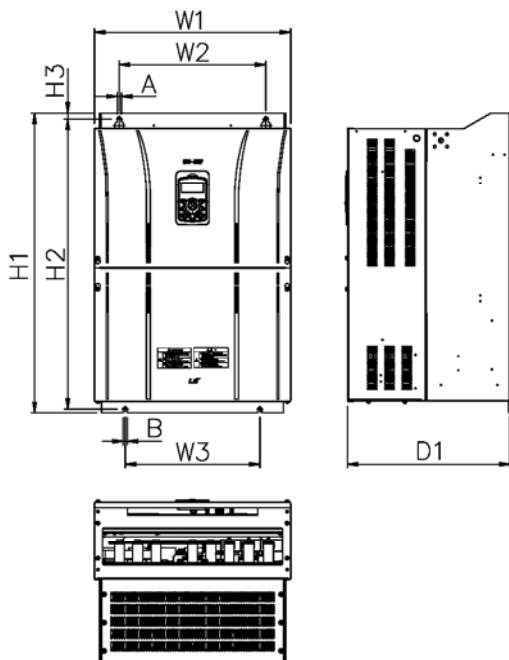

mm (inches)

Inverter capacity	W1	W2 / W3	H1	H2	H3	D1	A	B
SV0550-0750 iS7-2	465 (18.3)	381 (15.0)	750 (29.52)	723.5 (28.48)	15.5 (0.61)	355.6 (14.0)	11 (0.43)	11 (0.43)

9) SV0550-0750iS7 (400V)

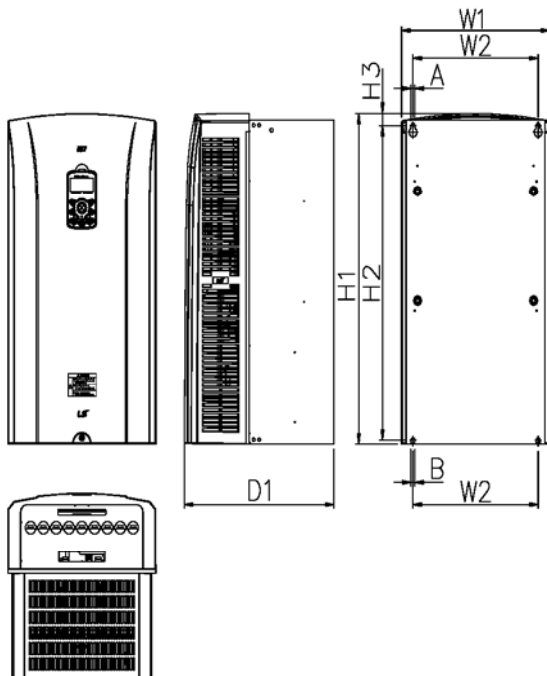

3

mm (Inches)

Inverter capacity	W1	W2	H1	H2	H3	D1	A	B
SV0550-0750 iS7-4	370.1 (14.57)	312.8 (12.31)	663.5 (26.12)	631.4 (24.85)	24.1 (0.94)	373.3 (14.69)	10 (0.39)	10 (0.39)

10) SV0900-1100iS7 (400V)

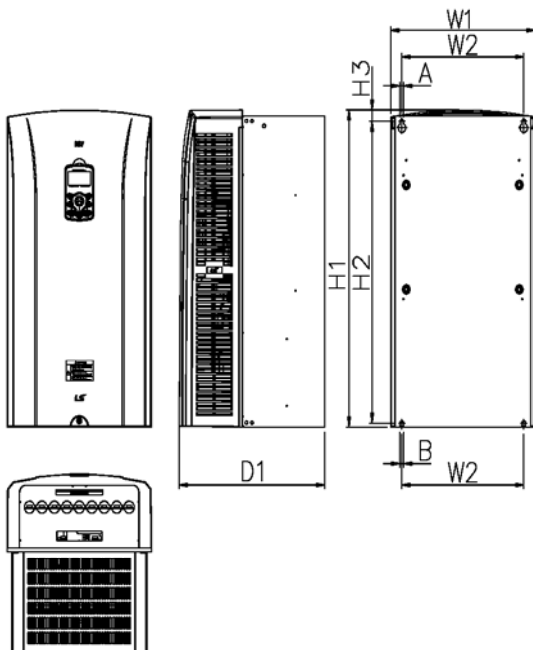

mm (inches)

Inverter capacity	W1	W2	W3	H1	H2	H3	D1	A	B
SV0900-1100 iS7-4	510 (20.07)	381 (15.0)	350 (13.77)	783.5 (30.84)	759 (29.88)	15.5 (0.61)	422.6 (16.63)	11 (0.43)	11 (0.43)

11) SV1320-1600iS7 (400V)

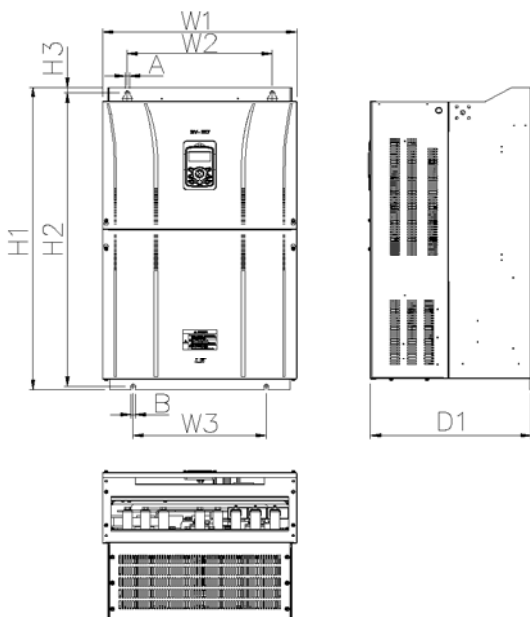

3

mm (inches)

Inverter capacity	W1	W2	W3	H1	H2	H3	D1	A	B
SV1320-1600 iS7-4	510 (20.07)	381 (15.0)	350 (13.77)	861 (33.89)	838 (32.93)	15.5 (0.61)	422.8 (16.63)	11 (0.43)	11 (0.43)

3.1.3 External dimension (UL Enclosed Type12, IP54 Type)

1) SV0008-0037iS7 (200V/400V)

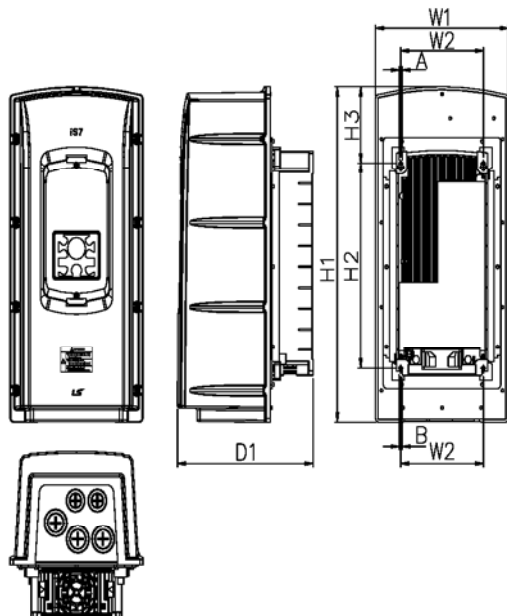

mm (inches)

Inverter capacity	W1	W2	H1	H2	H3	D1	A	B
SV0008-0037 iS7-2/49	204.2 (8.03)	127 (5.0)	419 (16.49)	257 (10.11)	95.1 (3.74)	208 (8.18)	5 (0.19)	5 (0.19)

2) SV0055-0075iS7 (200V/400V)

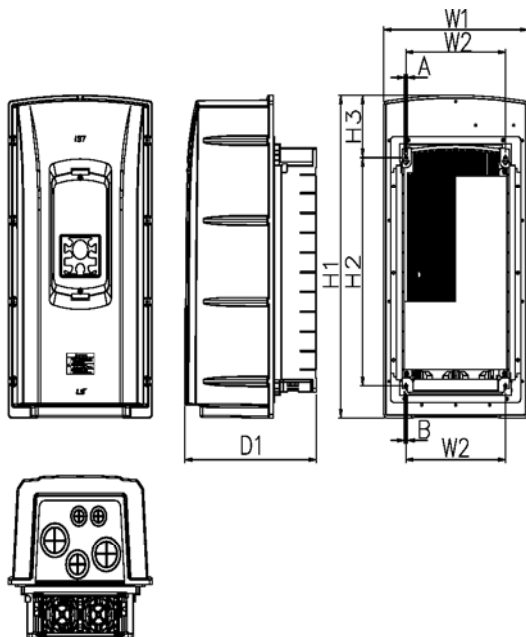

mm (inches)

Inverter capacity	W1	W2	H1	H2	H3	D1	A	B
SV0055-0075 iS7- 2/4	254 (10.0)	176 (6.92)	460.6 (18.13)	327 (12.87)	88.1 (3.46)	232.3 (9.14)	5 (0.19)	5 (0.19)

3) SV0110-0150iS7 (200V/400V)

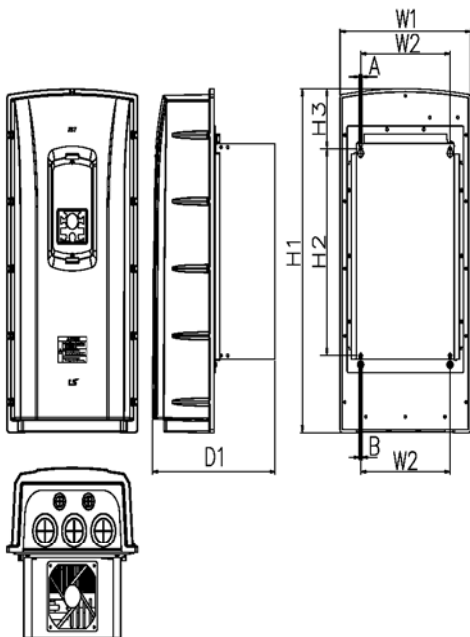

mm (inches)

Inverter capacity	W1	W2	H1	H2	H3	D1	A	B
SV0110-0150 iS7-2/4	313.1 (12.32)	214.6 (8.44)	590.8 (23.25)	355 (13.97)	101.7 (4.0)	294.4 (11.59)	6.5 (0.25)	6.5 (0.25)

4) SV0185-0220iS7 (200V/400V)

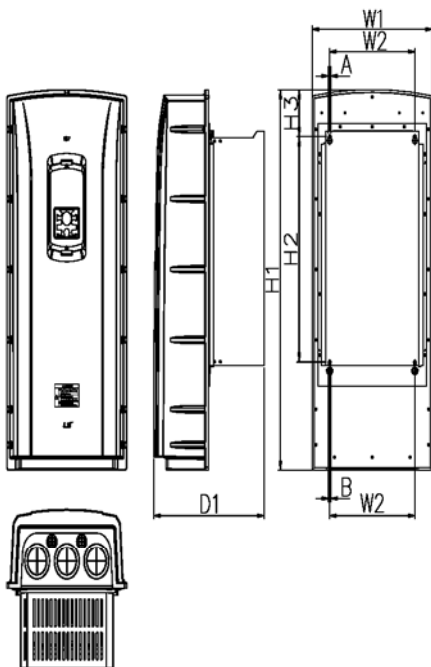

mm (inches)

Inverter capacity	W1	W2	H1	H2	H3	D1	A	B
SV0185-0220 iS7-2/4	343.2 (13.51)	243.5 (9.58)	750.8 (29.55)	445 (17.51)	91.6 (3.60)	315.5 (12.42)	6.5 (0.25)	6.5 (0.25)

3.1.4 Dimension and Weight of frame (UL Enclosed Type 1, IP 21 Type)

Inverter Capacity	W [mm]	H [mm]	D [mm]	EMC&DCL Weight [Kg]	Only EMC Product weight[Kg]	Only DCL Product weight[Kg]	Non EMC and DCL Product weight[Kg]
SV0008iS7-2/4	150	284	200	5.5	4.5	5.0	4.5
SV0015iS7-2/4	150	284	200	5.5	4.5	5.0	4.5
SV0022iS7-2/4	150	284	200	5.5	4.5	5.0	4.5
SV0037iS7-2/4	150	284	200	5.5	4.5	5.0	4.5
SV0055iS7-2/4	200	335	225	10	8.4	9.3	7.7
SV0075iS7-2/4	200	335	225	10	8.4	9.3	7.7
SV0110iS7-2/4	250	385	284	20	17.2	16.8	14
SV0150iS7-2/4	250	385	284	20	17.2	16.8	14
SV0185iS7-2	280	461.6	298	30	27	25.9	22.9
SV0220iS7-2	280	461.6	298	30	25.8	25.9	22.9
SV0300iS7-2	300	570	265.2	-	-	-	29.5
SV0370iS7-2	370	630	281.2	-	-	-	44
SV0450iS7-2	370	630	281.2	-	-	-	44
SV0550iS7-2	465	750	355.6	-	-	-	72.5
SV0750iS7-2	465	750	355.6	-	-	-	72.5
SV0185iS7-4	280	461.6	298	27.4	23.5	23.3	19.7
SV0220iS7-4	280	461.6	298	27.4	23.5	23.5	20.1
SV0300iS7-4	300.1	594.1	303.2	-	-	41	28
SV0370iS7-4	300.1	594.1	303.2	-	-	41	28
SV0450iS7-4	300.1	594.1	303.2	-	-	41	28
SV0550iS7-4	370	663.4	371	-	-	63	45
SV0750iS7-4	370	663.4	371	-	-	63	45
SV0900iS7-4	510	784	422.6	-	-	101	-
SV1100iS7-4	510	784	422.6	-	-	101	-

Inverter Capacity	W [mm]	H [mm]	D [mm]	EMC&DCL Weight [Kg]	Only EMC Product weight[Kg]	Only DCL Product weight[Kg]	Non EMC and DCL Product weight[Kg]
SV1320IS7-4	510	861	422.6	-	-	114	-
SV1600IS7-4	510	861	422.6	-	-	114	-

Note

Weight[Kg] above indicates the total weight including EMC FILTER and DCL. (excluding box packing) 30 through 75 kW (200V) products don't have an option type. 30 through 160kW(400V) products have only DCL option type.

3.1.5 Dimension and Weight of Frame (UL Enclosed Type 12, IP54 Type)

Inverter Capacity	W [mm]	H [mm]	D [mm]	EMC&DCL Weight[Kg]	Only EMC Weight[Kg]	Only DCL Weight[Kg]	Non EMC&DCL Weight[Kg]
SV0008IS7-2/4	204.2	419	208	8.2	7.2	7.7	6.7
SV0015IS7-2/4	204.2	419	208	8.2	7.2	7.7	6.7
SV0022IS7-2/4	204.2	419	208	8.2	7.2	7.7	6.7
SV0037IS7-2/4	204.2	419	208	8.2	7.2	7.7	6.7
SV0055IS7-2/4	254	460.6	232.3	12.8	10.2	12.1	9.5
SV0075IS7-2/4	254	460.6	232.3	12.9	10.3	12.2	9.6
SV0110IS7-2/4	313.1	590.8	294.4	25.6	22.8	22.4	19.6
SV0150IS7-2/4	313.1	590.8	294.4	25.9	23.1	22.7	19.9
SV0185IS7-2	343.1	750.8	315.5	38.3	34.2	34.1	29.9
SV0220IS7-2	343.2	750.8	315.5	38.3	34.2	34.1	29.9
SV0185IS7-4	343.2	750.8	315.5	34.9	31	31	27.1
SV0220IS7-4	343.2	750.8	315.5	34.9	31	31	27.1

Note

Weight[Kg] above indicates total weight. (excluding packing)
0.75~22 kW products have only IP54 type product.

3.1.6 Installation Guide (UL Enclosed Type12, IP54 Type)

1) How to separate IP54 keypad cover and keypad

- Release the upper/lower screw on the transparent keypad cover and then separate the transparent cover from the inverter.
- Separate the keypad from the inverter.



2) How to separate IP54 front cover

- Loosen the captive screws (nine or thirteen, depending on the size of the frame) around the edge of the cover.
- Remove the cover.

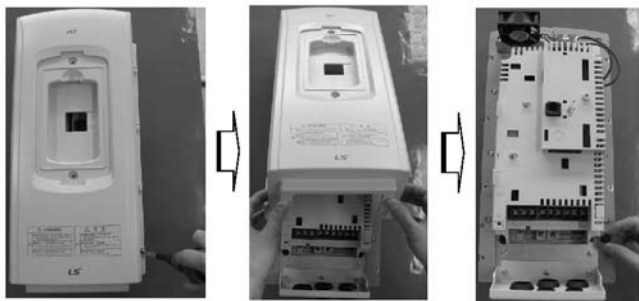

2) Mounting the inverter

- Remove the four rubber packings on the corner.
- Mount the inverter onto fixing hole on the panel and securely tighten the four screws or bolts.
- Place the four rubber packings to the each corner.

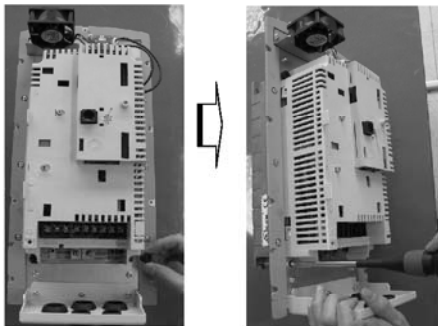

3) Power cable wiring

- Connects the input/output power cable as followed picture.
- Refer to Chapter 4 Wiring for the detailed wiring.

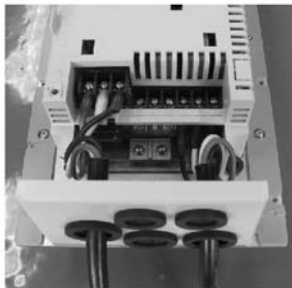

4) How to attach the IP54 front cover

- Place the front cover matching with plate hole.
- Securely tighten the screw at the corner of front cover.
- Connect the cable to the keypad and then place the front cover on the inverter.
- Place the transparent keypad cover on the keypad and tighten the upper/lower screw.

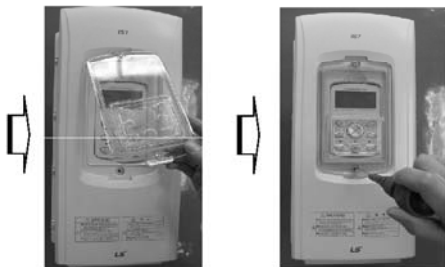

4.1 Wiring

4.1.1 How to separate front cover when wiring

Remove Keypad on the product and release fixed volt of the lower end of up cover.

1) How to separate Keypad

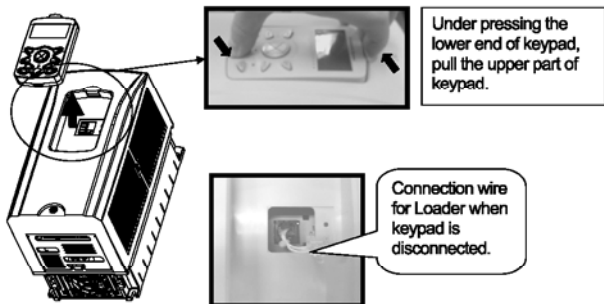

2) How to assemble plug when connecting Keypad

As showing figures below, install the keypad after connecting the plug.



3) How to separate front cover

[IP21 Type]

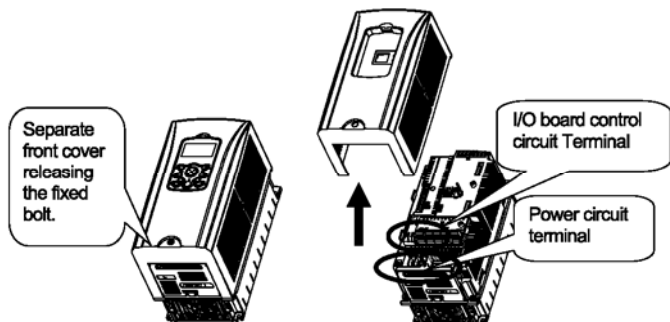

[IP54 Type]

Separate the transparent keypad cover releasing fixed bolt and then separate keypad. Separate the front cover releasing fixed bolt. Before wiring, IP54 product must be installed on the panel.

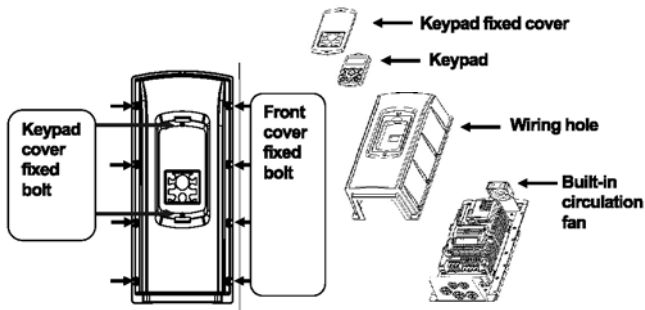

4.1.2 How to separate front cover when wiring (90~180 kW 400V, 30~75kW 200V)

Releasing the right/left fixed bolt on the lower front cover and get down the lower front cover and then open it. Now, you can wire power part (R/S/T, P/N, U/V/W) and signal cable (terminal block, encoder option, communication operation, PLC option etc.).

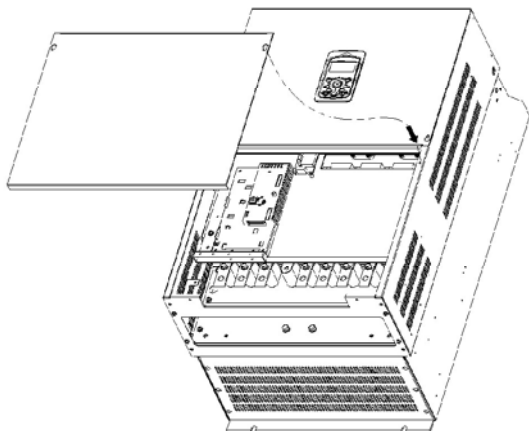

4.1.3 Built-in EMC Filter

IS7 inverter has built-in EMC Filter. It has effect in reducing air electric wave noise of inverter input part. It's initial setting is OFF. If you are to ON, Connect please short pin on the EMC filter ON/OFF Connector.

1) How to set EMC Filter functions (Less than 7.5kW Products)

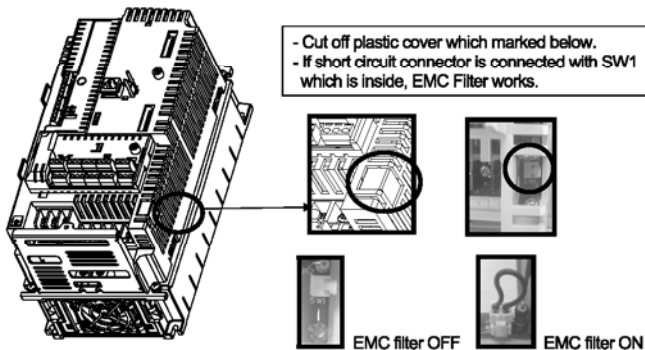

2) How to remove EMC Filter ON/OFF connector (Less than 7.5kW Product)

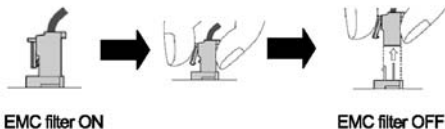

Check the voltage by a tester in 10minute after cutting the power supply. In case separate with connector, pull the connector while pressing fixed hasp. When reinstalling, be sure to hook the hasp of the connector. (If it is hard to separate them, please use radio pincher or tweezers.)

3) How to set EMC Filter functions (11~22kW Products)

EMC filter ON/OFF set terminal is located in lower part of the 11~22KW Terminal as shown figure below. Initial set is OFF. When the green wire is connected in upper metal connection terminal, EMC filter is ON and EMC filter is OFF if it is connected in insulated connection terminal.

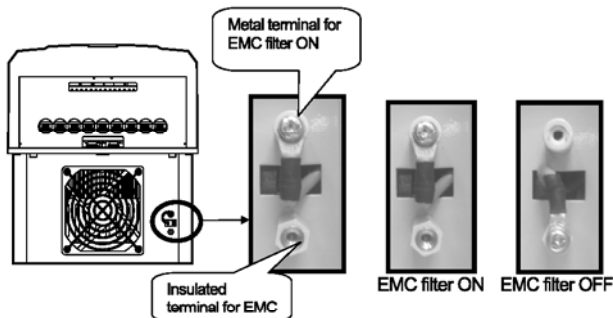

EMC filter has effect in reducing air electronic wave while being used in power source of symmetrical ground method. Be sure to use EMC filter in symmetrical ground method such as Y connection.

⚠ Caution

Leakage current increases while EMC filter is ON. Do not use EMC filter when the input is asymmetrical way such as Delta connection. It may cause an electric shock.

Asymmetrical Ground structure

1-phase is grounded in Delta connection		Grounded middle tap of 1-phase in Delta connection	
Grounded in 1-phase end		Non-grounded 3-Phase connection	

4.1.4 Wiring precaution

- 1) The internal circuits of the inverter will be damaged if the incoming power is connected and applied to output terminals (U, V, W).
- 2) Use ring terminals with insulated caps when wiring the input power and motor wiring.
- 3) Do not leave wire fragments inside the inverter. Wire fragments can cause faults, breakdowns, and malfunctions.
- 4) For input and output, use wires with sufficient size to ensure voltage drop of less than 2%. Motor torque may drop of operating at low frequencies and a long wire run between inverter and motor.
- 5) The cable length between inverter and motor should be less than 150m (492ft). Due to increased leakage capacitance between cables, overcurrent protective feature may operate or equipment connected to the output side may malfunction. [But for products of less than 30kW, the cable length should be less than 50m (164ft).]
- 6) The main circuit of the inverter contains high frequency noise, and can hinder communication equipment near the inverter. To reduce noise, install line noise filters on the input side of the inverter.
- 7) Do not use power factor capacitor, surge killers, or RFI filters on the output side of the inverter. Doing so may damage these components.
- 8) Always check whether the LCD and the charge lamp for the power terminal are OFF before wiring terminals. The charge capacitor may hold high-voltage even after the power is disconnected. Use caution to prevent the possibility of personal injury.
- 9) Do not connect with MC at output pare of inverter and make MC On/Off during operation. It can cause the Trip or damage of inverter.

4.1.5 Grounding

- 1) The inverter is a high switching device, and leakage current may flow. Ground the inverter to avoid electrical shock.
- 2) The ground impedance for 200V class is 100 ohm or less and 400V class 10ohm or less .
- 3) Connect only to the dedicated ground terminal of the inverter. Do not use the case or the chassis screw for grounding.
- 4) As a minimum, grounding wire should meet the specifications listed below. Grounding wire should be as short as possible and should be connected to the ground point as near as possible to the inverter.

Inverter Capacity	Grounding wire size (mm ²)	
	200V class	400V class
0.75 ~ 3.7kW	3.5	2
5.5 ~ 7.5 kW	5.5	3.5
11 ~ 15 kW	14	8
18.5 ~ 22 kW	22	14
30 ~ 45 kW	22	22
55 ~ 75 kW	38	38
90 ~ 110 kW	-	60
132 ~ 160 kW	-	100

4.1.6 Terminal wiring diagram (POWER terminal block)

1) Wiring of Inverter below 7.5kW

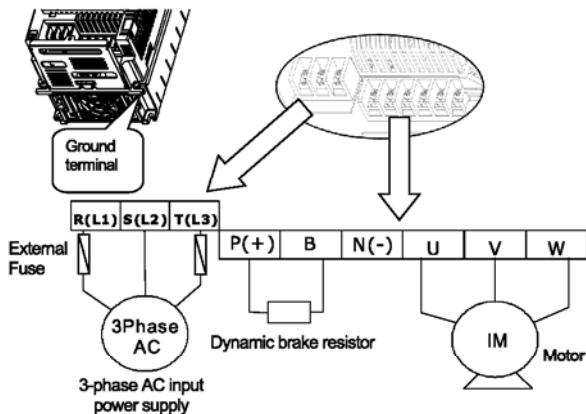

2) Wiring of 11~22kW Product

R(L1)	S(L2)	T(L3)	P(+)	B	N(-)	U	V	W
-------	-------	-------	------	---	------	---	---	---

3) Wiring of 30~75kW Product

R(L1)	S(L2)	T(L3)	P1(+)	P2(+)	N(-)	U	V	W
-------	-------	-------	-------	-------	------	---	---	---

4) Wiring of 90~160kW Product

R(L1)	S(L2)	T(L3)	P(+)	N(-)	U	V	W
-------	-------	-------	------	------	---	---	---

Note

Products over 11kW have a linear arrangement of terminal blocks. Products for 0.75~160kW have built-in DC Reactor, so it doesn't necessary any other DC Reactor connection. Ground terminal must be grounded. Do not use ground to command for ground cable, welding machine and power machine etc. Ground cable must be wire as short as possible. If ground terminal of inverter is far from the inverter, electric potential of inverter terminal ground can be unstable because leakage current of inverter can be generated from inverter.

4.1.7 Terminals of main circuit

1) 0.75 ~ 22 kW (200V/400V)

(1) Built-in dynamic braking unit used

Connect P(+) and B terminal of inverter to the dynamic braking unit when built-in dynamic unit is used.

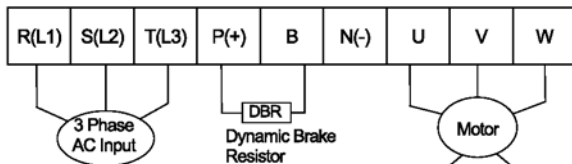

(2) Optional dynamic braking unit used

Connects P(+) terminal of inverter to P/(+) terminal of the dynamic braking unit and N(-) terminal of inverter to N/(-) terminal of the dynamic braking unit. B terminal of inverter is not used.

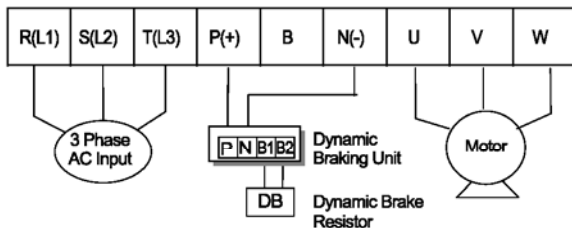

Terminal Symbol	Terminal Name	Description
R(L1),S(L2),T(L3)	AC power supply input	Connects normal AC input
P(+)	(+) DC voltage terminal	(+) DC link voltage terminal
N(-)	(-) DC voltage terminal	(-) DC link voltage terminal.
P(+),B	Dynamic brake resistor	Connects dynamic brake resistor.
U,V,W	Inverter output	Connects the 3 phase induction motor

2) 30 ~ 75 kW (200V, 400V)

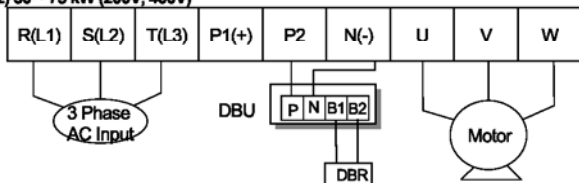

Terminal Symbol	Terminal Name	Description
R(L1), S(L2), T(L3)	AC power supply input	Connects normal AC input
P1(+)	(+)DC voltage terminal	(+)DC link voltage terminal, it is located in front of DCL terminal.
P2, N(-)	Dynamic brake unit connection, DC common terminal ¹⁾	Voltage terminal connecting Dynamic brake unit, DC common terminal
N(-)	(-)DC voltage terminal	(-)DC link voltage terminal.
U, V, W	Inverter output	Connects the 3-phase induction motor.

¹⁾ When using this terminal as a DC common, special considerations are required. Be sure to consult with our sales representative.

3) 90 ~ 160 kW (400V)

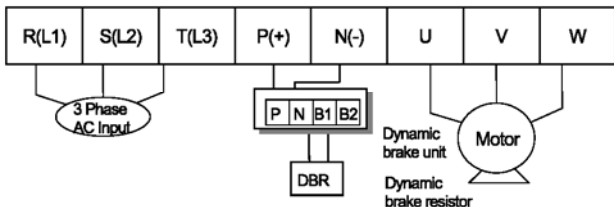

Terminal Symbol	Terminal Name	Description
R(L1), S(L2), T(L3)	AC power supply input	Connects normal AC input
P(+)	(+)DC voltage terminal	(+)DC link voltage terminal
N(-)	(-)DC voltage terminal	(-)DC link voltage terminal
P(+), N(-)	External brake unit connection	Voltage terminal connecting Dynamic brake unit.
U, V, W	Inverter output	Connects the 3-phase induction motor.

4.1.8 Specifications of power terminal block and Exterior fuse

Inverter applied	Terminal Screw size	Screw torque ¹⁾ (Kg·cm)	Cable ²⁾				Exterior fuse		
			mm ²		AWG		Current	Voltage	
			R,S,T	U,V,W	R,S,T	U,V,W			
200V	0.75 kW	M4	7.1~12	2.5	2.5	14	14	10A	500V
	1.5 kW	M4	7.1~12	2.5	2.5	14	14	15A	
	2.2 kW	M4	7.1~12	2.5	2.5	14	14	20A	
	3.7 kW	M4	7.1~12	4	4	12	12	32A	
	5.5 kW	M4	7.1~12	6	6	10	10	50A	
	7.5 kW	M4	7.1~12	10	10	8	8	63A	
	11 kW	M6	30.6~38.2	16	16	6	6	80A	
	15 kW	M6	30.6~38.2	25	22	4	4	100A	
	18.5 kW	M8	61.2~91.8	35	30	2	2	125A	
	22 kW	M8	61.2~91.8	35	30	2	2	160A	
	30 kW	M8	61.2~91.8	70	70	1/0	1/0	200A	
	37 kW	M8	61.2~91.8	95	95	2/0	2/0	250A	
	45 kW	M8	61.2~91.8	95	95	2/0	2/0	350A	
55 kW	M10	89.7~122.0	120	120	3/0	3/0	400A		
75 kW	M10	89.7~122.0	150	150	4/0	4/0	450A		
400V	0.75~1.5kW	M4	7.1~12	2.5	2.5	14	14	10A	500V
	2.2 kW	M4	7.1~12	2.5	2.5	14	14	15A	
	3.7 kW	M4	7.1~12	2.5	2.5	14	14	20A	
	5.5 kW	M5	24.5~31.8	4	2.5	12	14	32A	
	7.5 kW	M5	24.5~31.8	4	4	12	12	35A	
	11 kW	M5	24.5~31.8	6	6	10	10	50A	
	15 kW	M5	24.5~31.8	16	10	6	8	63A	
	18.5 kW	M6	30.6~38.2	16	10	6	8	70A	
	22 kW	M6	30.6~38.2	25	16	4	6	100A	
	30~37 kW	M8	61.2~91.8	25	25	4	4	125A	
	45 kW	M8	61.2~91.8	70	70	1/0	1/0	160A	
	55 kW	M8	61.2~91.8	70	70	1/0	1/0	200A	
	75 kW	M8	61.2~91.8	70	70	1/0	1/0	250A	
	90 kW	M12	182.4~215.0	100	100	4/0	4/0	350A	
110 kW	M12	182.4~215.0	100	100	4/0	4/0	400A		
132 kW	M12	182.4~215.0	150	150	300	300	450A		
160 kW	M12	182.4~215.0	200	200	400	400	450A		

1) : Apply the prescribed torque for the terminal screws. If the screws are loose, it might cause a failure.

2) : Use 600V 75°C copper lincs.

The entire cable length should be below 200m. In case of connection of the motor, the entire length should not exceed 200m because if a motor is connected from a remote location, the over current protection function might be started by the harmonics caused by the floating volume increase within the cables or a failure of the device connected to the secondary side might occur. The entire cable length should be below 200m too when you connect more than one motor. Do not use a triplex cable in case of distance wiring. (50m when below 3.7K)

In case of lengthy wiring, Use thick wire in order to reduce line voltage drop and decrease the carrier frequency or use a micro surge filter.

$$\text{Line Voltage Drop [V]} = (\sqrt{3} \times \text{wire resistance [m}\Omega/\text{m}] \times \text{wire length [m]} \times \text{Current [A]}) / 1000$$

Distance between inverter and motor	Up to 50 m	Up to 100 m	Over 100 m
Permitted carrier frequency	Below 15 kHz	Below 5 kHz	Below 2.5 kHz

4.1.9 Control terminal line diagram (Basic I/O terminal block, below 22kW)

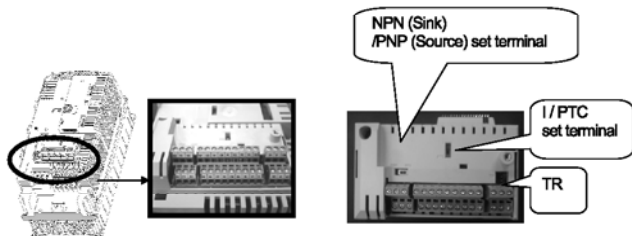

1) How to set NPN (Sink)/PNP (Source)

IS7 serves 2 sequence input terminal of control circuit: NPN mode (Sink mode) and PNP mode (Source mode). It is possible to change the logic of input terminal with NPN mode (Sink mode) and PNP mode (Source mode) by using NPN (Sink)/PNP (Source) set terminal. Each mode connecting methods are follows.

(1) NPN mode (Sink mode)

Set NPN (Sink)/PNP (Source) switch into NPN. CM (24V GND) is common terminal of contact point input signal. Initial set of Factory default is NPN mode (Sink mode).

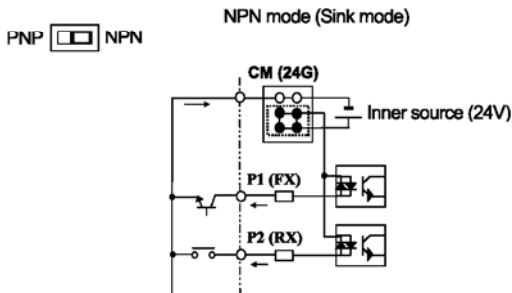

(2) PNP mode (Source mode) – When use inner source

Set NPN (Sink)/PNP (Source) switch into PNP. 24 (24V inner source) is common terminal of contact point input signal. PNP mode (Source mode) – Set NPN (Sink)/PNP (Source) switch into PNP When use exterior source.

If you want try to use exterior 24V source, connect exterior source (-) terminal with CM (24V GND).

PNP NPN PNP mode (Source mode) – When using Inner source

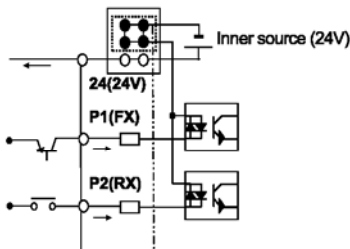

4

PNP NPN PNP mode (Source mode) – When using external source

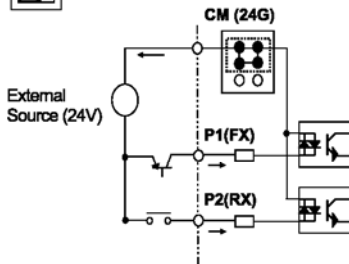

1) Example of Distribution

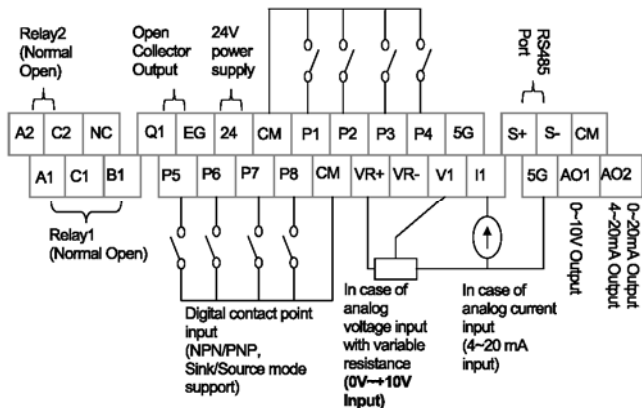
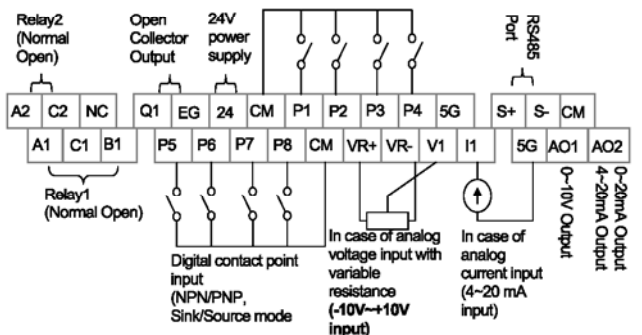

TR terminal is RS485 communication terminal resistor (120 Ω).

4.1.10 Control terminal line diagram (Insulated I/O terminal block, above 30kW)

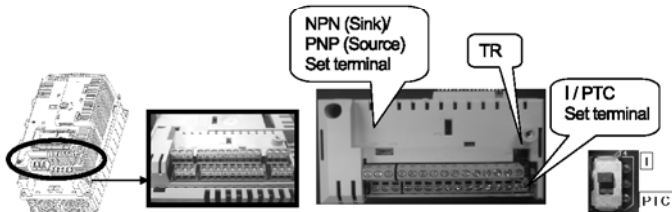

1) Example of Distribution

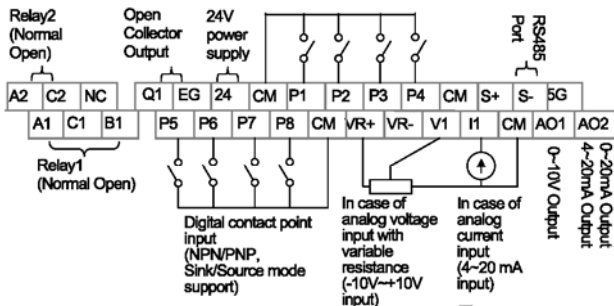
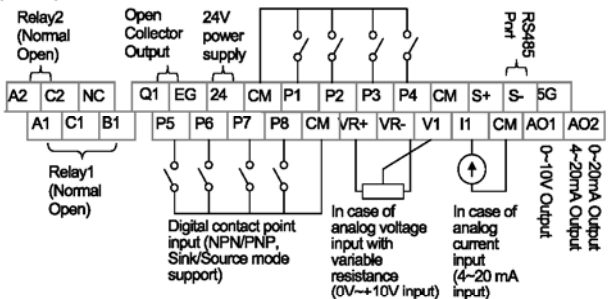

4.1.11 Control circuit terminal

1) Contact point start function selection

Type	Terminal Symbol	Terminal Name	Terminal Description	
Input Signal	Contact point start function selection	P1~P8	Multi-function input1~8	Available by defining as multi-function input
		CM	Sequence common terminal	Common terminal of the contact point input terminal (note : In case of Basic I/O, common terminal is different from the 5G common terminal)
	Analog Frequency	VR(+)	Frequency setting Power (+) terminal	Power supply for analog frequency setting Maximum output is +12V, 100mA.
		VR(-)	Frequency setting power (-) terminal	Power supply for analog frequency setting Maximum output is -12V, 100mA.
		V1	Frequency setting (voltage)	Becomes set frequency with input of DC -10~10V. Unipolar 0~+10[V], Bipolar(-10[V]~10[V]) input resistance 20kΩ
I1	Frequency setting (current)	Becomes set frequency with input of DC 0~20mA input resistance 249Ω		
5G	Frequency setting common terminal	Common terminal of analog frequency setting signal and analog voltage and current terminals (note : In case Basic I/O, common terminal are different from the CM common terminal.)		
Output Signal	Analog	A01	Multi-function analog voltage output terminal	Select the one among Output frequency, Output current, DC voltage. - Output voltage : 0~10V - Maximum output voltage : 10V - Maximum output current: 10mA
		A02	Multi-function analog current output terminal	Select the one among Output frequency, Output current, Output voltage, DC voltage. - Output current: 4~20mA (0~20mA) - Maximum output current: 20mA
	Contact Point	Q1	Multi-function terminal (open collector)	DC 26V, below 100mA
		EG	Common terminal for open collector	External power supply common earth terminal of the open collector
		24	Exterior 24V power	Maximum output current: 150mA
		A1, B1, C1	Fault signal output	Protection function is activated to break output. (below AC250V 1A, DV30V 1A) - Fault signal : A1-C1 electrified (B1-C1 unelectrified) - Normal signal : B1-C1 electrified (A1-C1 unelectrified)
		A2, C2	Multi-function relay 2 output A contact point	Output the signal while running. User defined multi-function output terminal. AC250V, below 5A DC30V, below 5A
	S+, S-, CM	RS-485 signal input terminal	RS-485 signal line (Refer to 'Communication Function' contained in iS7 User Manual. You can download it from LSIS website. (http://www.lsis.biz). This provided manual is the simple version of iS7 User Manual.	

4.1.12 Specifications of signal terminal block distribution

Type	Terminal Name	Cable size		Electric specifications
		mm ²	AWG	
P1~P8	Multi-function input terminal			-
CM	Contact point common terminal (In case of Basic I/O, CM is different from 5G)			Common earth for multi function input terminal
VR+	Analog frequency setting (+) power supply	0.33 ~1.25	16~22	Output voltage : +12V Maximum output voltage : 100mA
VR-	Analog frequency setting (-) power supply			Output voltage : -12V Maximum output voltage : 100mA
V1	Multi-function analog voltage input terminal			Input voltage : 0~12V or -12~12V
I1	Multi-function analog current input terminal			0~20mA input Internal resistance : 249Ω
AO1	Multi-function analog voltage output terminal			Maximum output voltage : 10V Maximum output current : 10mA
AO2	Multi-function analog current output terminal			Maximum output current : 20mA
5G	Frequency setting common terminal (In case of Basic I/O, 5G is different from CM)	0.33 ~2.0	14~22	Common terminal of analog frequency setting signal and analog current and voltage terminals
Q1	Multi-function terminal (open collector)			DC26V, below 100mA
EG	Earth terminal for external power supply	0.33 ~1.25	16~22	Maximum output current : 150mA
24	External 24V power supply			
A1	Multi function relay 1 output A contact point	0.33 ~2.0	14~22	AC250V, below 5A DC30V, below 5A
B1	Multi function relay 1 output B contact point			AC250V, below 5A DC30V, below 5A
C1	Multi function relay 1 contact point common terminal			AC250V, below 5A DC30V, below 5A
A2	Multi function relay 2 output A contact point			AC250V, below 5A DC30V, below 5A
C2	Multi function relay 2 contact point common terminal			AC250V, below 5A DC30V, below 5A
S+,S-	RS485 signal input terminal			0.75mm ² (18AWG), Shield Type Twisted-pair Wire
CM	RS485 common terminal			For multi connection, RS485 power ground (Shield) connection terminal

 **Caution**

Do not use more than 3M remote cable for the keypad. Failure of the signals on the keypad might occur. To prevent radiated emissions in the analogical and digital signals, you must put a ferrite in the wires of these signals.

Ex. Brand Würth Elektronik ref. 74271132

4.2 Operation Checking

IS7 provides EASY START MODE helping with the basic parameter setting using the keypad by distribution shown above when power is first supplied.

4.2.1 Easy start

Easy Start gets started when power is first supplied after you purchase the product or power is re-supplied after the set parameters are all initialized.

- Easy Start Mode gets started first even in case of an inverter trip.
- Easy Start Mode does not operate during the inverter running.

4.2.2 Easy start operation

It operates in the following sequence.

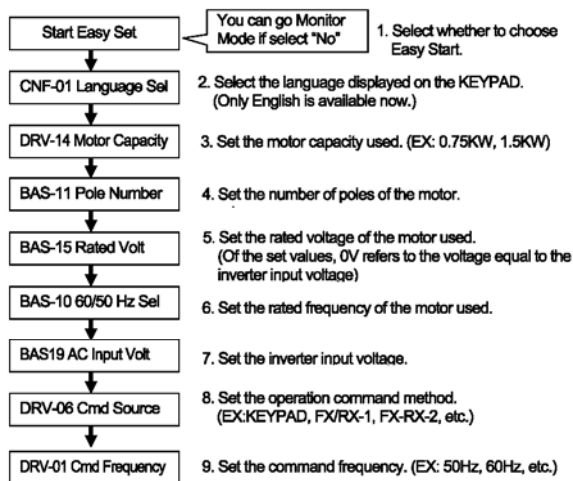

* You can move to Monitor Mode by pressing ESC at any time while you set the Easy Start mode.

4.2.3 Checking for normal working

1) Motor forward/reverse direction and Normal working checking by KEYPAD operation
After setting Cmd Source of DRV-06 is 0 : Keypad, Freq Ref Src of DRV-07 is 0 : Keypad-1 and set DRV-01 : Cmd Frequency into temporary speed, Command forward operation by pressing FWD please. At this time, shaft of motor at the side of load rotates into counterclock wise direction. Otherwise, it must be changed 2 terminals among the inverter output terminal U, V, W.

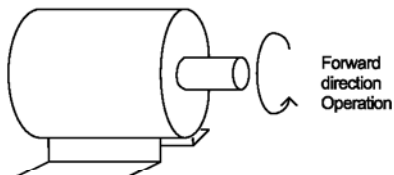

M E M O

5.1 How to Use Keypad

5.1.1 Standard KEYPAD appearance and description (Graphic keypad)

Standard Keypad is used in Inverter parameter setting, Monitor display and Inverter operations.



1) Dimensions

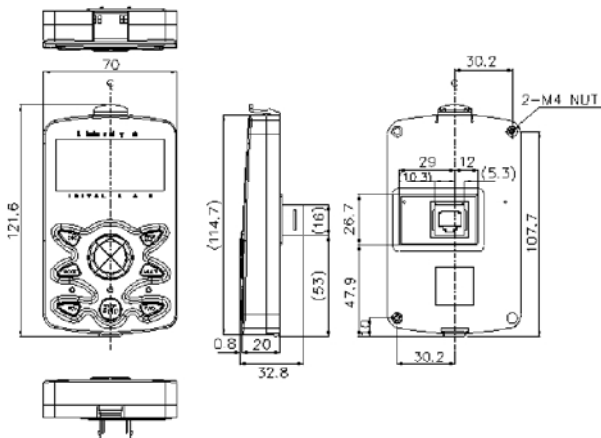

2) Key Functions

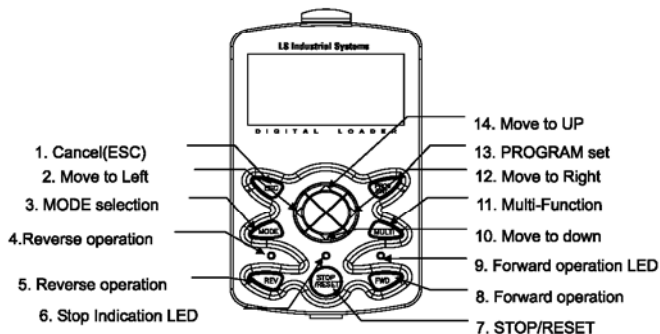

Section	Buttons	Key name	Function Description
KEY		Mode Key	- Change MODE
		Program Key	- Write, change and save data in parameter codes.
		Up key	- Used when writing data or move codes.
		Down Key	- Used when writing data or move codes.
		Left/Right Key	- Movement among groups. - Movement of cursor in writing.
		Multi Function Key	- Register Jog or User codes.
		Cancel Key	- In writing, it is possible to use saved data previously if press this button before pressing Program Key. - Move to first code when code moving is required in a group. - Move to Monitor mode when Mode moving.
		Forward Key	- Motor rotates Forward direction.
		Reverse Key	- Motor rotates Reverse direction.
	Stop/Reset Key	- Stop Under operating. - Trip release when a trip occurs.	

3) Composition of Display

(1) Monitor Mode

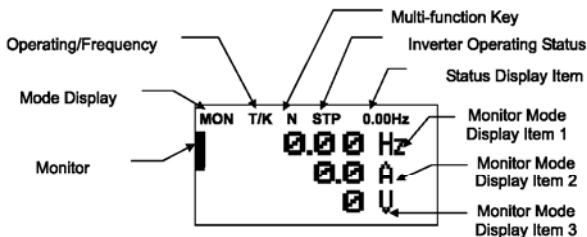

(2) Parameter change display

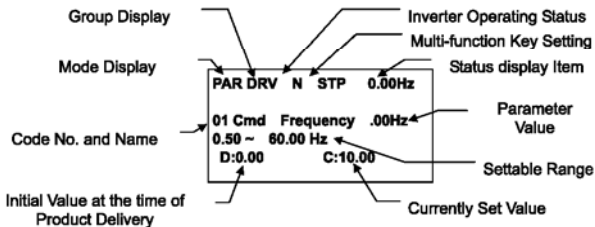

4) Display Item List

- (1) Mode Display Items : see "Mode shift" on this chapter 5.1.3.
- (2) Group Display Items : see "Group shift" on this chapter 5.1.4.
- (3) Operation Command/Frequency Command Display Items (Type of Seq and number of steps are displayed during auto sequence operation)

(4) Monitor Display Items

No	Function	Display	Description
1	Mode Display	MON	Monitor Mode
		PAR	Parameter Mode
		U and M	USR & Macro Mode
		TRP	Trip Mode
		CNF	Config Mode
2	Operating Command	K	Keypad operation command
		O	FBus Option operation command
		A	Application Option operation command
		R	Built-in 485 operation command
		T	Terminal block operation command
3	Frequency Command	K	Keypad frequency command
		V	V1 or (V1+I1) input frequency command
		I	I1 input frequency command
		P	Pulse input frequency command
		U	Frequency command during UP operation (Up-Down operation)
		D	Frequency command during DOWN operation (Up-Down operation)
		S	Frequency command during STOP operation (Up-Down operation)
		O	FBus Option frequency command
		X	V2, I2 frequency command of sub-terminal block
		J	Jog frequency command
		R	Internal 485 frequency command
		1~9 A~F	Sequential frequency command
4	Multi Function Key Setting	JOG Key	Used for shift to Keypad JOG mode
		Local/Remote	Used to select local or remote operation
		UserGrp SelKey	Used to register parameters as a user group in the parameter mode or delete parameters in the user group.
5	Inverter	STP	Motor stopped

No	Function	Display	Description
	Operating Status	FWD	Operating forward
		REV	Operating reversely
		DC	DC output
		WAN	Warning
		STL	Stalling
		SPS	Speed Search
		OSS	SW OC controlled
		OSH	HW OC controlled
		TUN	Auto Tuning

(5) Status Display Items: see "Operating status monitoring" on this chapter 5.1.7.

(6) Monitor Mode Display Items: see "Operating status monitoring" on this chapter 5.1.7.

5.1.2 Menu composition

SV-IS7 series inverter consists of the following 5 modes. Each mode has its own function items suitable for the properties and especially the parameter mode displays the functions necessary for inverter operation in groups.

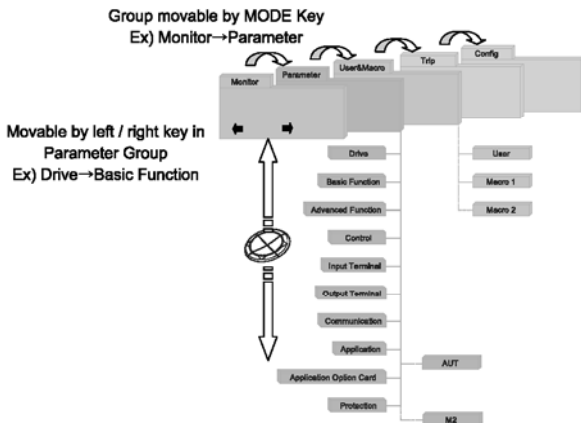

Mode	Display	Description
Monitor mode	MON	Displays information on the operating status of the inverter. Can monitor frequency setting, operating frequency display, output current and voltage, etc.
Parameter mode	PAR	Can set functions necessary for operation. Divided into a total of 12 groups, each suitable for the functional difficulty and objective.
User and Macro mode	U and M	You can group only necessary functions by using user group and macro group. This is not displayed when the user code is not registered or when the user/macro mode shifts with the mode key unless the macro is not selected.

Mode	Display	Description
Trip mode	TRP	In case of a failure during operation, the failure type and information on the operating frequency/current/ voltage at the time of the failure occurring are displayed. You can also monitor the type of the trips that previously occurred. Trip Mode is not displayed when there is no previous failure history during normal operation.
Config mode	CNF	You can set the use environment for the inverter itself that is not directly related to operating functions such as keypad language selection, monitor mode environment selection, display of the option card type mounted on the inverter, parameter initialization and copying.

1) Parameter mode

Mode	Display	Description
Drive group	DRV	Has functions necessary for operation including frequency/acceleration/deceleration time setting and operation command selection, etc.
Basic group	BAS	Can set the basic functions such as the motor parameter and sequential frequency, etc.
Advanced function group	ADV	Can set the acceleration/deceleration pattern and frequency control function, etc.
Control function group	CON	Can set functions related to sensorless and vector control.
Input terminal function group	IN	Can set functions related to the inverter input terminal block including multi-function digital input and analog input.
Output terminal function group	OUT	Can set the inverter output terminal block functions such as the relay and analog output.
Communication function group	COM	Sets the functions related to built-in 485 communication and communication option card in such a case.
Application function group	APP	Sets functions such as PID control and auto sequence operation.
Auto Sequence run group	AUT	This group is displayed if Auto Sequence Group in APP is selected and sets the functions necessary for auto sequence operation.

Mode	Display	Description
Application option group	APO	Sets functions related to the encoder option and PLC option card, if they are used.
Protection group	PRT	Can set functions for protecting the motor and inverter.
Motor 2 function group(Motor 2)	M2	This group is displayed if you select Motor #2 among the multi-function input terminal functions and sets functions related to Motor #2.

2) User and Macro mode

Group	Display	Description
User group	USR	Of the function items of each group of the parameter mode, the items that need to be monitored or that are frequently set by the user are grouped and displayed. It is registered by using the multi-function key of the keypad.
Macro group	MCx	The functions necessary for the inverter according to the load type can be grouped and selected at the time of delivery from the factory. If the user selects a desired operation type, the groups displayed in MC1 or MC2 are shown. You can select them in CNF Mode. For more details, see 8-48 page, 8.1.31 Addition to Macro group in detailed user's manual from website.

5.1.3 Mode shift

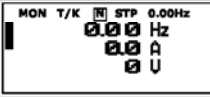
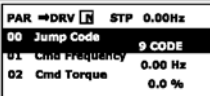
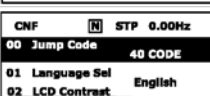
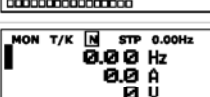
 <p>MON T/K [N] STP 0.00Hz 0.0 Hz 0.0 A 0 U</p>	<ul style="list-style-type: none"> - Power on, a display emerges as shown on the left. The present mode is the monitor mode. - Press Mode key once.
 <p>PAR →DRV [N] STP 0.00Hz 00 Jump Code 9 CODE 01 Cmd Frequency 0.00 Hz 02 Cmd Torque 0.0 %</p>	<ul style="list-style-type: none"> - You have shifted to Parameter Mode. - Press Mode key once.
 <p>CNF [N] STP 0.00Hz 00 Jump Code 40 CODE 01 Language Sel English 02 LCD Contrast</p>	<ul style="list-style-type: none"> - You have shifted to Config Mode. - Press Mode key once.
 <p>MON T/K [N] STP 0.00Hz 0.0 Hz 0.0 A 0 U</p>	<ul style="list-style-type: none"> - You come back to Monitor Mode.

5.1.4 Group shift

1) Group Shift in Parameter Mode

If you press Right key in the Parameter Mode, the display changes as follows.
If you press Left key, the display order will be reversed.

<pre> MON T/K [N] STP 0.00Hz 0.00 Hz 0.00 A 0.00 U </pre>	<ul style="list-style-type: none"> - Power on, a display emerges as shown on the left. The present mode is the monitor mode. - Press Mode key once.
<pre> PAR =>DRV [N] STP 0.00Hz 00 Jump Code 9 CODE 01 Cmd Frequency 0.00 Hz 02 Cmd Torque 0.0 % </pre>	<ul style="list-style-type: none"> - You have shifted to Parameter Mode. - The drive group of Parameter Mode is being displayed. - Press Right key once.
<pre> PAR =>BAS [N] STP 0.00Hz 00 Jump Code 20 CODE 01 Aux Ref Src None 02 Cmd 2nd Src Fx/Rx-1 </pre>	<ul style="list-style-type: none"> - You shift to Basic Function Group(BAS). - Press Right key once.
<pre> PAR =>ADV [N] STP 0.00Hz 00 Jump Code 24 CODE 01 Acc Pattern Linear 02 Dec Pattern Linear </pre>	<ul style="list-style-type: none"> - You shift to Advanced Function Group(ADV). - Press Right Shift key 7 times.
<pre> PAR =>PRT [N] STP 0.00Hz 00 Jump Code 40 CODE 01 Load Duty Heavy Duty 02 Phase Loss Chk [] </pre>	<ul style="list-style-type: none"> - The group changed in sequence, PRT is displayed. - Press Right Shift key once.
<pre> PAR =>DRV [N] STP 0.00Hz 00 Jump Code 9 CODE 01 Cmd Frequency 0.00 Hz 02 Cmd Torque 0.0 % </pre>	<ul style="list-style-type: none"> - You come back to the Drive Group(DRV) of Parameter Group.

5.1.5 Code (Function Item) shift

1) Code shift (function Items) in modes and groups

Using Up and Down keys: The following figures give an example of shifting the code by using Up and Down keys in DRV and BAS of Parameter Mode. Code shift in other modes are the same.

	<ul style="list-style-type: none"> - Power on, the display emerges as on the left. The present mode is Monitor Mode (MON). - Press Mode key once.
	<ul style="list-style-type: none"> - The display shows DRV of Parameter Mode. If DRV is not displayed, press Mode key until DRV emerges or press ESC once.
	<ul style="list-style-type: none"> - If you press Down key, you will shift to code No. 0 in DRV of Parameter Mode as shown on the left. - Press Right key once.
	<ul style="list-style-type: none"> - You shift to BAS of Parameter Mode. - You can shift the code by using Up or Down key.

5.1.6 Parameter setting

1) Parameter setting in modes and groups

This gives an example of changing frequency in the Drive Group of Parameter Mode. You can do so too in other modes or groups.

<pre> PAR →DRV [N] STP 0.00Hz 00 Jump Code 9 CODE 01 Cmd Frequency 0.00 Hz 02 Cmd Torque 0.0 % </pre>	<ul style="list-style-type: none"> - This is the initial display of Parameter Mode. - Press Down key.
<pre> PAR →DRV [N] STP 0.00Hz 00 Jump Code 9 CODE 01 Cmd Frequency 0.00 Hz 02 Cmd Torque 0.0 % </pre>	<ul style="list-style-type: none"> - You have shifted to 01 frequency setting code. - Press PROG.
<pre> PAR →DRV [N] STP 0.00Hz 01 Cmd Frequency 0.00 Hz 0.50 ~ 60.00 Hz D:0.00 C:0.00 </pre>	<ul style="list-style-type: none"> - The cursor flashes so that you can enter frequency. - If you want to set the frequency at 10Hz, move the cursor to the desired place using Left/Right keys.
<pre> PAR →DRV [N] STP 0.00Hz 01 Cmd Frequency 10.00 Hz 0.50 ~ 60.00 Hz D:0.00 C:0.00 </pre>	<ul style="list-style-type: none"> - Enter 10Hz using Up key and press PROG.
<pre> PAR →DRV [N] STP 0.00Hz 00 Jump Code 9 CODE 01 Cmd Frequency 10.00 Hz 02 Cmd Torque 0.0 % </pre>	<ul style="list-style-type: none"> - The desired frequency has been changed to 10Hz.

5.1.7 Operating status monitoring

1) Using monitor mode

You can monitor 3 items at a time in Monitor Mode. Some items including frequency can be edited. Displayed items can be selected by the user in Config Mode(CNF).

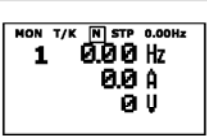
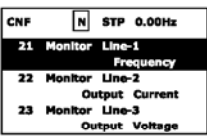
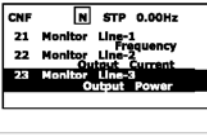
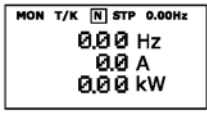
 <p>MON T/K [N] STP 0.00Hz 1 0.00 Hz 0.0 A 0 V</p>	<ul style="list-style-type: none"> - This is the initial display of Monitor Mode. - The frequency, current and voltage are set as the default monitor items at the time of product delivery. - Of the displayed items, for frequency, the goal frequency is displayed during stop and operating frequency during operation.
 <p>CNF [N] STP 0.00Hz 21 Monitor Line-1 Frequency 22 Monitor Line-2 Output Current 23 Monitor Line-3 Output Voltage</p>	<ul style="list-style-type: none"> - You can set the items to display in Monitor Mode in sequence at 21~23 in CNF. - Move to 23 using Down key.
 <p>CNF [N] STP 0.00Hz 21 Monitor Line-1 Frequency 22 Monitor Line-2 Output Current 23 Monitor Line-3 Output Power</p>	<ul style="list-style-type: none"> - Change the 23 item in Monitor Mode to output power.
 <p>MON T/K [N] STP 0.00Hz 0.00 Hz 0.0 A 0.00 kW</p>	<ul style="list-style-type: none"> - The third displayed item in Monitor Mode has been changed to output power.

2) Possible to monitoring items

Mode	Code	Function Display	Setting Range	Initial Value	
CNF	20	Anytime Para	0	Frequency	0 : Frequency
	21	Monitor Line-1	1	Speed	0 : Frequency
	22	Monitor Line-2	2	Output Current	2:Output Current
	23	Monitor Line-3	3	Output Voltage	3:Output Voltage
			4	Output Power	
			5	WHour Counter	
			6	DCLink Voltage	
			7	DI State	
			8	DO State	
			9	V1 Monitor[V]	
			10	V1 Monitor[%]	
			11	I1 Monitor[mA]	
			12	I1 Monitor[%]	
			13	V2 Monitor[V]	
			14	V2 Monitor[%]	
			15	I2 Monitor[mA]	
			16	I2 Monitor[%]	
			17	PID Output	
			18	PID ref Value	
			19	PID Fdb Value	
			20	Torque	
			21	Torque Limit	
			22	Trq Bias Ref	
			23	Speed Limit	
24			Load Speed		

5.1.8 Failure status monitoring

1) Failure during operation

<pre> TRP current Over Voltage (01) 01 Output Freq 48.30 Hz 02 Output Current 33.3 A </pre>	<p>- In case of a failure during operation, the mode automatically shifts to Trip Mode and the type of the current failure is displayed.</p>
<pre> TRP Last-1 01 Output Freq 48.30 Hz 02 Output Current 33.3 A 03 Inverter State Stop </pre>	<p>- If you press Down key, the output frequency, current and operating status at the time of the failure occurring are displayed.</p>
<pre> MON T/K [N] STP 0.0A 0.00 Hz 0.0 A 0 V </pre>	<p>- If the failure status is terminated by Reset, the keypad before the failure comes back.</p>

2) Multiple failures at a time

5

<pre> TRP current Over Voltage (02) 01 Output Freq 48.30 Hz 02 Output Current 33.3 A </pre>	<p>- In case of multiple failures, the number of failures is displayed next to the failure type. - Press PROG.</p>
<pre> TRP current 00 Trip Name (2) 0 Over Voltage 1 Externa Trip </pre>	<p>- The type of failures is displayed. - Press PROG.</p>
<pre> TRP current Over Voltage (02) 01 Output Freq 48.30 Hz 02 Output Current 33.3 A </pre>	<p>- The display mode before failure checking comes back.</p>

3) Saving and monitoring of failure history

Previous failures are saved in Trip Mode. Up to 5 failures can be saved. Failure history is saved not only by Reset but also in case of a low voltage failure due to power off.

If the number of failure exceeds 5, the failures before the latest 5 ones are automatically deleted.

<table border="1"> <tr><td>TRP current</td></tr> <tr><td>Over Voltage (02)</td></tr> <tr><td>01 Output Freq 48.30 Hz</td></tr> <tr><td>02 Output Current</td></tr> </table>	TRP current	Over Voltage (02)	01 Output Freq 48.30 Hz	02 Output Current	<ul style="list-style-type: none"> - In case of a failure during operation, the mode automatically shifts to Trip Mode with the trip displayed. 	
TRP current						
Over Voltage (02)						
01 Output Freq 48.30 Hz						
02 Output Current						
<table border="1"> <tr><td>MON T/K N STP</td></tr> <tr><td>0.0A</td></tr> <tr><td>0.00 Hz</td></tr> <tr><td>0.0 A</td></tr> <tr><td>0 V</td></tr> </table>	MON T/K N STP	0.0A	0.00 Hz	0.0 A	0 V	<ul style="list-style-type: none"> - If you press Reset or the terminal is entered, the failure above is automatically saved and the display goes back to the place before the failure. - Move to Trip Mode using Mode key.
MON T/K N STP						
0.0A						
0.00 Hz						
0.0 A						
0 V						
<table border="1"> <tr><td>TRP current</td></tr> <tr><td>00 Trip Name (2)</td></tr> <tr><td>Over Voltage</td></tr> <tr><td>01 Output Freq 48.30 Hz</td></tr> </table>	TRP current	00 Trip Name (2)	Over Voltage	01 Output Freq 48.30 Hz	<ul style="list-style-type: none"> - The most recent failure is saved in Last-1 code. - Press Right key. 	
TRP current						
00 Trip Name (2)						
Over Voltage						
01 Output Freq 48.30 Hz						
<table border="1"> <tr><td>TRP current</td></tr> <tr><td>00 Trip Name (1)</td></tr> <tr><td>External Trip</td></tr> <tr><td>01 Output Freq 48.30 Hz</td></tr> </table>	TRP current	00 Trip Name (1)	External Trip	01 Output Freq 48.30 Hz	<ul style="list-style-type: none"> - A previous failure is saved in Last-2 code. - If another failure occurs, what was in Last-2 moves to Last-3. 	
TRP current						
00 Trip Name (1)						
External Trip						
01 Output Freq 48.30 Hz						

5.1.9 How to initialize parameter

You can initialize the parameter that has been changed by the user to the initial state at the time of delivery. Not only the entire parameter but a group of the parameter mode can be selected and initialized.

<pre> MON T/K [N] STP 0.0A 0.00 Hz 0.0 A 0 U </pre>	- Monitor Mode is displayed.
<pre> CNF [N] STP 0.0A 00 Jump Code 9 CODE 01 language Sel English 02 Inv S/W Ver Version 1.00 </pre>	- Shift to CNF by using Mode key.
<pre> CNF [N] STP 0.0A 31 Option-2 Type None 32 Option-3 Type None 40 Parameter Init ---- No ---- </pre>	- Shift to code 40 using Down key. - Press PR OG.
<pre> CNF [N] STP 0.0A 40 Parameter Init ---- No ---- 1 All Groups 2 DRV </pre>	- Of the Parameter items to initialize, select All Groups and press PROG.
<pre> CNF [N] STP 0.0A 31 Option-2 Type None 32 Option-3 Type None 40 Parameter Init ---- No ---- </pre>	- Initialization finished, you come back to the initialization selection display.

6.1 Basic Functions

6.1.1 How to set frequency (When you want to set frequency)

Group	Code No.	Function Display	Initial Display	
DRV	07	Freq Ref Src	0	KeyPad-1
			1	KeyPad-2
			2	V1
			3	I1
			4	V2
			5	I2
			6	Int 485
			7	Encoder
			8	Fied Bus
			9	PLC

Select the frequency setting method in code 07 of DRV Group. Digital setting by using the keypad, analog setting by using voltage (V1) and current (I1) input of the control terminal block and built-in RS485 port or communication option are available for operating frequency setting from the external controller.

1) Frequency Setting Using Keypad 1 : KeyPad-1

Group	Code No.	Function Display	Initial Setting	Setting Range	Unit	
DRV	01	Cmd Frequency	-	0.00	0.00~Max Frequency	Hz
	07	Freq Ref Src	0	KeyPad-1	0~9	-

You can change the frequency by changing the frequency using the keypad and pressing PROG.

Set DRV group 07 at KeyPad-1. The frequency changes is saved in the memory if you change the frequency at DRV group 01 and press PROG.

2) Frequency Setting Using Keypad 2 : KeyPad-2

Group	Code No.	Function Display	Setting Displayed	Setting Range	Unit	
DRV	01	Cmd Frequency	-	0.00	0.00~Max Frequency	Hz
	07	Freq Ref Src	1	KeyPad-2	0~9	-

You can change the frequency using Up and Down keys on the keypad. Set DRV group 07 at KeyPad-2.

Frequency is changed if you press PROG in DRV Group 01 and then press Up or Down. If you press PROG, it will be saved in the memory and if you press ESC, it will not be saved.

3) Frequency setting by voltage input (V1 terminal) of the terminal block: V1

Group	Code No.	Function Display	Setting Displayed	Setting Displayed	Unit
DRV	07	Freq Ref Src	2	V1	-

Enter -10~+10V or 0~+10V using the voltage (V1) input terminal of the terminal block. If you enter -10~+10V, you can change the revolution direction of the motor according to the symbol of the voltage signals.

(1) If you enter 0~+10V,

Group	Code No.	Function Display	Setting Displayed	Setting Frequency	Unit	
DRV	07	Freq Ref Src	2	V1	-	
IN	01	Freq at 100%	-	60.00	0.00~ Max Frequency	Hz
	05	V1 Monitor	-	0.00	0~10	V
	06	V1 Polarity	0	Unipolar	Unipolar/Bipolar	-
	07	V1 Filter	-	10	0~10000	msec
	08	V1 volt x1	-	0.00	0~10	V
	09	V1 Perc adj y1	-	0.00	0~100	%
	10	V1 Volt x2	-	10.00	0~10	V
	11	V1 Perc adj y2	-	100.00	0~100	%
	16	V1 Inverting	-	No	No/Yes	-
	17	V1 Quantizing	-	0.04	0.04~10	%

Set No.06 of the input terminal block group (IN) at Unipolar. Enter the volume resistance into the V1 terminal by using the voltage output of the external voltage output or VR output terminal of the inverter control terminal block as follows.

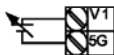

When connecting external power source



When connecting internal power source

(2) If you use 0~+10V of the external circuit,

If the volume resistance is connected to the terminal block (IN-01 Freq at 100%) : set the operating frequency of the maximum voltage input. Set the operating frequency of which the values set in the input terminal block function group (IN) No. 11 or 15 is 100%.
E.g.1) When IN-01 is 40.00 and the default value is set to IN-16, if 10V is input into the V1 terminal, operation is at 40.00Hz.

E.g.2) When IN-11 is 50% and the default value is set between IN-01 and IN-16, if 10V is input into the V1 terminal, operation is at 30.00Hz (50% of max 60Hz).

IN-05 V1 Monitor : displays the voltage input into the V1 terminal. This is used for monitoring the currently input voltage.

IN-07 V1 Filter : used when the set frequency value fluctuates greatly due to the environment such as noise. If you set the filter time constant high, you can reduce the frequency fluctuation but the response gets slower. The higher the time constant is, the time (t) becomes longer. The set time refers to the time it takes the frequency set in the inverter to increase by up to about 63% when the voltage input is input by step as follows.

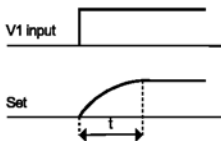

IN-08 V1 Volt X1 ~ IN-11 V1 Perc y2: You can set the slope and offset value for the input voltage.

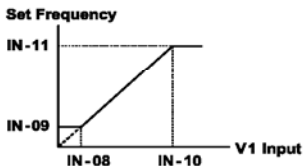

IN-16 V1 Inverting : If you set at No. 1 Yes, you can reverse the present revolution direction.

IN-17 V1 Quantizing : used when there is a lot of noise in the analog signals input into the terminal. You can also reduce noise to some extent by using the IN-07 low pass filter value but the higher the value is, the responsiveness becomes slower and pulsation of a long cycle might occur. The resolving power of output frequency for analog input decreases but the noise effect is reduced by the quantizing function in a system sensitive to noise.

The set quantization value is the percentage of the maximum analog input value. Therefore if the maximum input value is 10V and the quantization value is set at 1%, the frequency changes by 0.06Hz (when the maximum frequency is 60Hz) at an interval of 0.1V. The output frequency when the input value increases and decreases differs so that the effect of analog input value fluctuation is removed.

If the quantization value is quadrisection and the analog input value increases, when a value three fourths the quantization value is input, the output frequency changes and from the next step it increases along with the quantization value as follows. If the analog input value decreases by 1/4 of the quantization value, the output frequency changes.

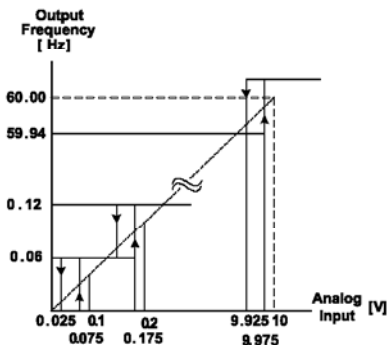

(3) If -10~+10V is input,

Group	Code No.	Function Display	Setting Displayed	Setting Range	Unit	
DRV	07	Freq Ref Src	2	V1	-	
IN	01	Freq at 100%	-	60.00	0.00~Max. Freq.	Hz
	05	V1 Monitor	-	0.00	0~10V	V
	06	V1 Polarity	1	Bipolar	Unipolar/ Bipolar	-
	12	V1 -volt x1'	-	0.00	0~10V	V
	13	V1 -Perc y1'	-	0.00	0~100%	%
	14	V1 -Volt x2'	-	-10.00	0~10V	V
	15	V1 -Perc y2'	-	-100.00	0~100%	%

Set IN-06 at Bipolar. Codes between 12 and 15 are displayed only when they are Bipolar and you can set the voltage between 0 and 10V which is input into the V1 terminal.

As follows, input into the V1 terminal in volume resistance by using the voltage output of the external controller or the VR output terminal of the inv enter control terminal block.

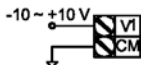

When -10~10V is used from the external circuit

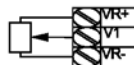

When connecting inner power source

The output frequency of bipolar voltage input (-10~+10V) is as follows.

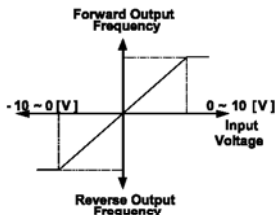

IN-12 V1 ~volt x1~ IN-15 V1 ~Perc y2: You can set the slope and offset value of the output frequency of (-) input voltage as follows.

E.g.) If the minimum (-) input voltage if V1 is -2V, the output ratio of -2V is 10% and maximum voltage is -8V and then you set the output ratio at 80%, the output frequency moves between 6Hz~48Hz.

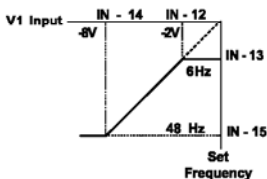

For setting of 0~+10V, see IN-08 V1 Volt X1 ~ IN-11 V1 Perc y2.

The selection of keypad or terminal block directions and motor rotation by bipolar voltage input is shown in the following table.

Operating Command	Voltage Input	
	0~10V	-10~0V
FWD	FWD	REV
REV	REV	FWD

4) Frequency setting by current input into terminal block (I1 Terminal)

Group	Code No.	Function Display	Setting Displayed		Setting Range	Unit
DRV	07	Freq Ref Src	3	I1	-	-
IN	01	Freq at 100%	-	60.00	0.00~ Max Freq	Hz
	20	I1 Monitor	-	0.00	0~20	mA
	22	I1 Filter	-	10	0~10000	msec
	23	I1 Curr x1	-	4.00	0~20	mA
	24	I1 Perc y1	-	0.00	0~100	%
	25	I1 Curr x2	-	20.00	0~20	mA
	26	I1 Perc y2	-	100.00	0~100	%
	31	I1 Inverting	0	No	No/Yes	-
	32	I1 Quantizing	-	0.04	0.04~10	%

Select I1 in DRV Group 07. Input current of 0~20mA into the I1 terminal of the terminal block to set frequency.

IN-01 Freq at 100% : sets the operating frequency at the maximum current input. The operating frequency when the value set in IN-26 is 100% is set.

E.g.1) If IN-01 is 40.00 and IN-23~26 is set at the default value, when 20mA is input into the I1 terminal, the operation is at 40.00Hz.

E.g.2) If IN-26 is 50% and IN-01, 23~26 are set at the initial value, when 20mA is input into the I1 terminal, the operation is at 30.00Hz.

IN-20 I1 Monitor : displays the current input into the I1 terminal. This is used for monitoring the current input at the moment.

IN-22 I1 Filter : The set time refers to the time it takes the input current which has been step input to reach about 63% of the I1 value that has been step input in the inverter.

IN-23 I1 Curr x1 ~ IN-26 I1 Perc y2 : You can set the slope of the output frequency and offset value against the current as follows.

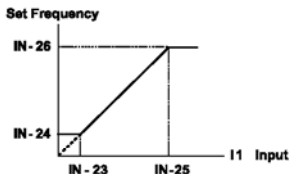

IN-31 I1 Inverting : You can turn the direction of the rotation.

IN-32 I1 Quantizing : the same as quantizing function of IN-17. See "IN-17 V1 Quantizing" on page 6-3 in detailed user's manual from website.

5) Frequency command by advanced I/O option card

You can input the frequency command by using -10~+10V (V2 terminal) and 0~20mA (I2terminal) if you mount an extended I/O card on the inverter option slot.

▶ -10~+10V Input

Group	Code No.	Function Display	Setting Displayed	Setting Range	Unit	
DRV	07	Freq Ref Src	4	V2	-	
IN	35	V2 Monitor	-	0.00	0~20	mA
	37	V2 Filter	-	10	0~10000	msec
	38	V2 Volt x1	-	0.00	0~10V	V
	39	V2 Perc y1	-	0.00	0~100	%
	40	V2 Volt x2	-	10.00	0~10	V
	41	V2 Perc y2	-	100.00	0~100	%
	42	V2 -Volt x1'	-	0.00	0~10	V
	43	V2 -Perc y1'	-	0.00	0~100	%
	44	V2 -Volt x2'	-	-10.00	0~10	V
	45	V2 -Perc y2'	-	-100.00	-100~0	%
	46	V2 Inverting	0	No	No/Yes	-
47	V2 Quantizing	-	0.04	0.04~10	%	

The voltage input of the extended I/O inputs bipolar voltage at -10V ~ +10V. Its operating method is the same as the Bipolar input of the V1 terminal, which was described on page 6-2 in detailed user's manual from website.

▶ 0 ~ 20mA Input

Group	Code No.	Function Display	Setting Displayed	Setting Range	Unit	
DRV	07	Freq Ref Src	5	I2	-	
IN	50	I2 Monitor	-	0.00	0~20	mA
	52	I2 Filter	-	15	0~10000	msec
	53	I2 Curr x1	-	4.00	0~20	mA
	54	I2 Perc y1	-	0.00	0~100	%
	55	I2 Curr x2	-	20.00	4~20	mA
	56	I2 Perc y2	-	100.00	0~100	%
	61	I2 Inverting	-	No	No/Yes	-
	62	I2 Quantizing	-	0.04	0.04~10	%

See the description of the I1 terminal on Page 6-4 in detailed user's manual from website.

6) Frequency setting by Encoder Option Card (If you want use pulse input to frequency command)

Group	Code No.	Function Display	Setting Displayed		Setting Frequency	Unit
DRV	07	Freq Ref Src	7	Encoder	-	-
IN	01	Freq at 100%	-	60.00	0.00~Max. Freq.	Hz
APO	01	Enc Opt Mode	2	Reference	0~2	-
	04	Enc Type Sel	0	-	0~2	-
	05	Enc Pulse Sel	2	A	0~2	-
	06	Enc Pulse Num	-	-	10~4096	-
	09	Pulse Monitor	-	-	-	kHz
	10	Enc Filter	-	10	0~10000	msec
	11	Enc Pulse x1	-	0.0	0~100	kHz
	12	Enc Perc Y1	-	0.00	0~100	%
	13	Enc Pulse x2	-	100.0	0~100	kHz
	14	Enc Perc y2	-	100.00	0~100	%

If you mount the encoder option card on the main body of the inverter, the code is displayed from APO-01.

APO-01 Enc Opt Mode, APO-05 Enc Pulse Sel : Select No.2 Reference for APO-01 in order to set the frequency with the encoder. Set APO-05 at No.2 A.

APO-04 Enc Type Sel, APO-06 Enc Pulse Sel : inputs the output method and number of pulses in harmony with the encoder specification.

APO-10 Enc Filter ~ APO-14 Enc Perc y2 : sets the filter time constant and minimum and maximum input frequency of the encoder input. The output frequency corresponding to the encoder input frequency is the same as that of voltage (V1) or current (I1) input.

APO-09 Pulse Monitor: displays the frequency of the pulse which is input when APO-01 Enc Opt Mode is set as Reference.

7) Frequency setting by RS-485 Communication : Int 485

Group	Code No.	Function Display	Setting Displayed	Setting Frequency	Unit
DRV	07	Freq Ref Src	6 Int 485	-	-
	01	Int485 St ID	- 1	0~250	-
COM	02	Int485 Proto	0 ModBus RTU	0~2	-
			1 ModBus ASCII	0~2	-
			2 LS Inv 485	0~2	-
	04	Int485 BaudR	3 9600	1200~38400	bps
	07	Int485 Mode	0 D8 / PN / S1	0~3	-
			1 D8 / PN / S2	0~3	-
			2 D8 / PE / S1	0~3	-
3 D8 / PO / S1			0~3	-	

If you set DRV-07 Freq Ref Src at Int 485, you can control the inverter through communication with the higher controller (PLC or PC) by using the RS485 (+S, -S) terminal of the terminal block. For details, see Communication Functions, Chapter 11.

Note: Please refer to User manual for communication options such as Profibus, Device-net, and PLC options.

6.1.2 Analog command frequency fixation

Group	Code No.	Function Display	Setting Displayed	Setting Range	Unit	
DRV	07	Freq Ref Src	0	Keypad-1	0-9	-
			1	Keypad-2	0-9	-
			2	V1	0-9	-
			3	I1	0-9	-
			4	V2	0-9	-
			5	I2	0-9	-
			6	Int 485	0-9	-
			7	Encoder	0-9	-
			8	Fied Bus	0-9	-
			9	PLC	0-9	-
IN	65-75	*Px Define	21 Analog Hold	65-75	-	

*Px: P1-P8, P9-P11 (option)

This is the function of fixing the operating frequency when the terminal selected as the Analog Hold among the multi-function terminals if you set the frequency by using the analog input of the control terminal block.

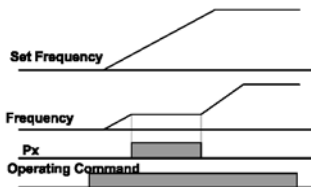

6.1.3 Changing frequency to revolution

If you set the Hz/Rpm Sel value at "1: Rpm Display, the frequency will change into revolution.

Group	Code No.	Function Display	Setting Displayed	Setting Range	Unit
DRV	21	Hz/Rpm Sel	1 Rpm Display	-	rpm

6.1.4 Sequential frequency setting

Group	Code No.	Function Display	Setting Displayed	Setting Range	Unit	
DRV	07	Freq Ref Src	-	-	-	
BAS	50~64	Step Freq - x	-	-	Hz	
IN	65~75	Px Define	7	Speed-L	-	-
			8	Speed-M	-	-
			9	Speed-H	-	-
			10	Speed-X	-	-
	89	InCheck Time	-	1	-	msec

*Step Freq - x : Step Freq -1~15, Px: P1~P8, P9~P11 (Option)

Sequential operation is available by using the multi-function terminal. Speed 0 frequency uses the frequency command selected in DRV Group No. 07.

Enter the desired step frequency in codes 50~64 of BAS.

Select the terminal to use as sequential input among multi-function terminals P1~P11 and set one of the sequential functions (Speed-L, Speed-M, Speed-H, Speed-X) for each. Speed-L, Speed-M, Speed-H and Speed-X are identified as binary codes and operation starts with the frequency set in BAS-50 ~ BAS-64 selected.

If multi-function terminals P6, P7 and P8 are set at Speed-L, Speed-M and Speed-H respectively, you can operate it as follows. In case of Speed-X being used, you can set up to Speed 16 when the highest bit is Speed-X.

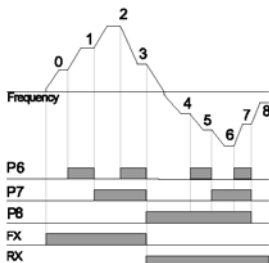

Speed	FX or RX	P8	P7	P6
0	✓	-	-	-
1	✓	-	-	✓
2	✓	-	✓	-
3	✓	-	✓	✓
4	✓	✓	-	-
5	✓	✓	-	✓
6	✓	✓	✓	-
7	✓	✓	✓	✓

[Example of speed-8]

If multi-function terminals P5, P6, P7 and P8 are set at Speed-L, Speed-M, Speed-H and Speed-X respectively, you can operate it as follows.

Speed	FX or RX	P8	P7	P6	P5
0	✓	-	-	-	-
1	✓	-	-	-	✓
2	✓	-	-	✓	-
3	✓	-	-	✓	✓
4	✓	-	✓	-	-
5	✓	-	✓	-	✓
6	✓	-	✓	✓	-
7	✓	-	✓	✓	✓
8	✓	✓	-	-	-
9	✓	✓	-	-	✓
10	✓	✓	-	✓	-
11	✓	✓	-	✓	✓
12	✓	✓	✓	-	-
13	✓	✓	✓	-	✓
14	✓	✓	✓	✓	-
15	✓	✓	✓	✓	✓

IN-89 In Check Time: If you use the multi-function terminal for sequential frequency setting, you can set the in check time for the terminal block input within the inverter. For example, if you set the in check time at 100msec and input multi-function terminal P6, it will be checked whether another terminal block input is input for 100msec. After 100msec, it is accelerated or decelerated by the frequency corresponding to P6 terminal.

6.1.5 Operating command setting method

Group	Code No.	Function Display	Initial Display
DRV	06	Cmd Source	0 Keypad
			1 Fx/Rx-1
			2 Fx/Rx-2
			3 Int 485
			4 Field Bus
			5 PLC

Select the operating command setting method in DRV Group code 06. For operating command, other than the basic operation using the keypad and multi-function terminal, you can also use the built-in RS485 communication, Fieldbus and Application Option Card.

1) Keypad Operating Command: Keypad

Group	Code No.	Function Display	Initial Display	Unit
DRV	06	Cmd Source	0	Keypad

If you set the DRV Group 06 with the keypad, operation starts using the FWD and REV keys on the inverter keypad and stops using Stop key.

2) Terminal Block operating command 1 : Fx/Rx-1

Group	Code No.	Function Display	Setting Display	Setting Range	Unit
DRV	06	Cmd Source	1	Fx/Rx-1	-
IN	65~75	Px Define	1	FX	-
	65~75	Px Define	2	RX	-
	88	Run On Delay	-	1.00	0.00~100

*Px: P1~P8, P9~P11 (option)

Set DRV Group 06 at Fx/Rx-1. Select the terminal used for FX and RX operating commands among multi-function terminals P1~P11 and set the function of the appropriate terminal of IN 65~75 at FX and RX. It stops if the FX and RX terminals are ON or OFF at the same time.

IN-88 Run On Delay: Operation starts after the set time, too when the FX or RX terminal is input. It can be used where operation start synchronization with an outside sequence is necessary.

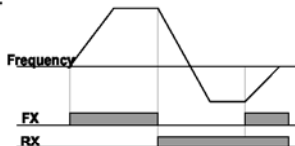

3) Terminal Block operating command 2 : Fx/Rx-2

Group	Code No.	Function Display	Setting Display	Setting Range	Unit
DRV	06	Cmd Source	2	Fx/Rx-2	-
IN	65~75	Px Define	1	FX	-
	65~75	Px Define	2	RX	-
	88	Run On Delay	-	1.00	0.00~100

*Px: P1~P8, P9~P11 (option)

FX terminal is used for operating command and RX terminal is for selecting the rotation direction. Set DRV Group 06 at Fx/Rx-2. Select the terminal used for FX and RX operating commands among multi-function terminals P1~P11 and set the function of the appropriate terminal of IN 65~75 at FX and RX.

IN-88 Run On Delay: Operation starts after the set time, too when the FX or RX terminal is input. It can be used where operation start synchronization with an outside sequence is necessary.

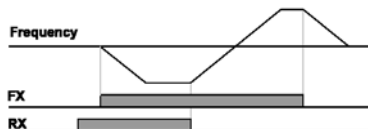

4) Operating Command by RS-485 Communication: Int 485

Group	Code No.	Function Display	Setting Display		Setting Range	Unit
DRV	06	Cmd Source	3	Int 485	-	-
COM	04	Int485 St ID	-	1	0~250	-
	05	Int485 Proto	0	ModBus RTU	-	-
	06	Int485 BaudR	3	9600	1200~38400	bps
	07	Int485 Mode	0	D8 / PN / S1	-	-

You can control the inverter through communication with a higher controller (PLC or PC) by using terminal RS485 (+S, -S) on the terminal block if you set DRV-06 Cmd Src at Int 485.

6.1.6 Prevention of forward or reverse rotation: Run Prevent

Group	Code No.	Function Display	Setting Display		Setting Range	Unit
ADV	09	Run Prevent	0	None	0~2	-

You can select a motor rotation direction to prevent.

None : Both forward and reverse are available.

Forward Prev : Forward operation is prevented.

Reverse Prev : Reverse operation is prevented.

6.1.7 Run immediately with power On: Power-on Run

Group	Code No.	Function Display	Setting Display		Setting Range	Unit
DRV	06	Cmd Source	-	1 ~ 2	-	-
ADV	10	Power-on Run	1	— yes —	No/Yes	-

With power supplied to the inverter and the terminal block operating command being ON, the inverter starts operating.

This is effective only when the DRV Group 06 command source is set at 1 (Fx/Rx-1) or 2 (Fx/Rx-2). At this time, if load (Fan load) is on the status of Free-Run, Trip may be occurred while operating. Change the bit 4 to 1 at CON-71 Speed Search and it makes the inverter can start with Speed Search. If not, inverter will be accelerating normal V/F

pattern without Speed Search.

If this function is not selected, operation resumes after the operating commands is turned OFF and ON again.

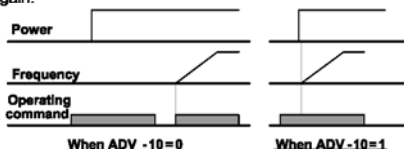

⚠ **Caution**

Be careful with this function, which causes the motor to rotate as soon as the power is supplied.

6.1.8 Setting of accelerating/decelerating time and pattern

1) Setting of accelerating/decelerating time on the basis of the maximum frequency

Group	Code No.	Function Display	Setting Display	Setting Range	Unit	
DRV	03	Acc Time	Below 75kW	20.0	0~600	sec
			Above 90kW	60.0		
	04	Dec Time	Below 75kW	30.0	0~600	sec
		Above 90kW	90.0			
	20	Max Freq	60.00	0~400	Hz	
BAS	08	Ramp T Mode	0	Max Freq	Max Freq/Delta Freq	-
	09	Time scale	1	0.1	0.01/0.1/1	sec

If you set BAS-08 at Max Freq, you can accelerate or decelerate at an equal slope on the basis of the maximum frequency regardless of the operating frequency.

The acceleration time set in DRV-03 is the time it takes the frequency to reach the maximum value from 0 Hz and the deceleration time of 04 is the time it takes the frequency to stop at 0 Hz from the maximum frequency.

E.g.) If you set the maximum frequency at 60.00 Hz, Acc/Dec time at 5 seconds and operating frequency at 30 Hz, the time required is 2.5 seconds.

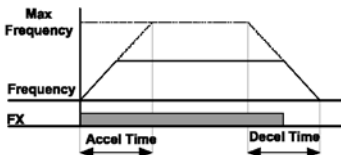

Caution

90 ~ 160 kW product's acceleration initial value is 60.0sec and deceleration initial value is 90.0sec. Please do not confuse that displayed value at left bottom of keypad is D : 20.0, D : 30.0 it is applied for below 75kW product.



BAS-09 Time scale : Used when precise Acc/Dec time is required due to the load characteristics or it is necessary to increase the maximum set time. It changes the units of all the functions related to time.

Setting	Range of Acc/Dec Time	Precision
0	0.01 sec	0.00 ~ 60.00
1	0.1 sec	0.0 ~ 600.0
2	1 sec	0 ~ 6000

Caution

Be careful because change of the unit leads to change of maximum settable time. If you change BAS-09 Time scale to 0(0.01sec) with Acc time set at 1000.0 seconds, the Acc time becomes 600.00 seconds.

2) Setting of Acc/Dec Time Based on Operating Frequency

Group	Code No.	Function Display	Setting Display	Setting Range	Unit
DRV	03	Acc Time	- 20.0	0~600	sec
	04	Dec Time	- 30.0	0~600	sec
BAS	08	Ramp T Mode	1 Delta Freq	Max Freq/Delta Freq	-

If you set BAS-08 as Delta Freq, you can set the Acc/Dec time by the time it takes the current frequency during operation at steady speed to reach the target frequency of the next step. If you set the Acc time at 5 seconds in case of step operation between 10Hz and 30Hz while it is static, the Acc time is as follows.

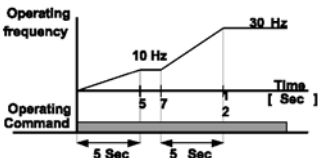

6.1.9 Motor output voltage adjustment

(Adjusting motor voltage when input power specification differs from motor voltage specification)

Group	Code No.	Function Display	Setting Display	Setting Range	Unit
BAS	15	Rated Volt	- 220	180~480	V

Inputs the voltage of the motor plate. The set voltage value is the output voltage value of the base frequency. Above the base frequency, if the input voltage is higher than the set voltage, the output is in proportion to the set value but if the input voltage is lower than the set voltage, the input voltage is produced. When 0 is set, the output voltage is corrected according to the input voltage when the inverter is static. Above the base frequency, if the input voltage is lower than the set voltage, the input voltage is produced.

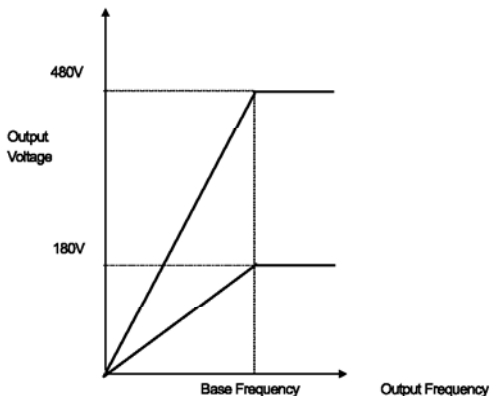

M E M O

A large rectangular area with a black border, containing horizontal dashed lines for writing.

7.1 Checking and Troubleshooting

7.1.1 Protective functions

1) Protection from output current and input voltage

Type	Category	Details	Remark
Over Load	Latch	A failure occurs when you select the motor overload failure and the load exceeds the set degree. Operation can resume after PRT-20 is set at values other than 0.	-
Under Load	Latch	A failure occurs when you select the underload protection function and the motor load is within the set underload level. Operation can resume after PRT-27 is set at values other than 0.	-
Over Current1	Latch	A failure occurs when the inverter output exceeds 200% of the rated current.	-
Over Voltage	Latch	A failure occurs when the DC circuit voltage exceeds the prescribed amount.	-
Low Voltage	Level	A failure occurs when the DC circuit voltage goes down below the prescribed degree.	-
Ground Trip	Latch	A failure occurs when current above the prescribed amount flows due to earth in the inverter output part. The earth causing current varies according to the capacity of the inverter.	-
E-Thermal	Latch	A failure occurs in order to prevent overheat during overload operation according to the inverse time thermal characteristic. Operation resumes if you set PRT-40 at values other than 0.	-
Out Phase Open	Latch	A failure occurs when one of the three phases output of the inverter is phase open. Operation resumes if you set PRT-05 bit 1 at 1.	-
In Phase Open	Latch	A failure occurs when one of the three phases input of the inverter is phase open. Operation resumes if you set PRT-05 bit 2 at 1.	-
Inverter OLT	Latch	This is the inverse time thermal characteristic protection against heat between 150% 1 minute to 200% 0.5 second on the basis of the inverter rated current. 200% 0.5 second might differ according to the inverter capacity.	-

2) Protection by internal circuit abnormality or external signals

Type	Category	Details	Remark
Fuse Open	Latch	A failure occurs when the inverter DC fuse responds to over current only above 30kW.	-
Over Heat	Latch	A failure occurs when the temperature of the inverter cooling fan rises over the prescribed degree.	-
Over Current2	Latch	A failure occurs when the DC part in the inverter detects short circuit current.	-
External Trip	Latch	This is an external failure signal by function selection of the multi-function terminal. Of the IN65~75 functions, No.3 External Trip is selected.	-
BX	Level	The inverter output is blocked by function selection of the multi-function terminal. Of the IN65~75 functions, No.4 BX is selected.	-
H/W-Diag	Fatal	Trouble with the memory device within the inverter(EPP Rom), analog-digital switch output(ADC Off Set) or CPU malfunction(Watch Dog-1, Watch Dog-2).	-
NTC Open	Latch	A failure occurs when abnormality is detected with the temperature detecting sensor of the power switch(IGBT).	-
Fan Trip	Latch	A failure occurs when abnormality is detected with the cooling fan. Operation resumes if PRT-79 is set at 0.	Only applied to below 22 kW
IP54 FAN Trip	Latch	Detected when IP54 product has a fault of internal circulation at FAN.	Only applied to IP54 product
PTC Trip	Latch	A failure occurs when resistance goes beyond the prescribed value after the external temperature sensor is connected to the terminal block. Operation resumes if PRT-34 is set at values other than 0.	-
ParaWrite Trip	Latch	Trouble during parameter writing with the inverter's main body from the keypad.	-
Over Speed Trip	Latch	A failure occurs when the motor speed goes up above the overspeed detection level. The detection level is set in PRT-70.	-
Dev Speed Trip	Latch	A failure occurs when the speed that got feedback from the encoder goes up above the	-

Type	Category	Details	Remark
		set variation value. Operation resumes if PRT-73 is set at 1.	
Encoder Trip	Latch	A failure occurs when PRT-77 Enc Wire Check is set at 1 and abnormality is detected for the set period of time.	-
Pre-PID Fail	Latch	A failure occurs when the control amount(PID feedback) is continuously input below the set value during Pre-PID operation by the function setting between APP-34 ~36, which is regarded as an abnormal state of the system.	-

3) Protection by KEYPAD and option

Type	Category	Details	Remark
Lost Keypad	Level	A failure occurs when operating commands come from the keypad or there is any problem with the communication between the keypad and inverter's main body in the Keypad JOG Mode. Operation resumes if PRT-11 is set at values other than 0. (occurs 2 seconds after the communication is interrupted)	-
Lost Command	Level	When there is a problem with the command if frequency or operating commands are given by the terminal block or communication command other than the keypad. Operation resumes if PRT-12 is set at values other than 0.	-
Option Trip-1	Level	When the option gets out of the option slot No. 1 after it was inserted during power supply or when communication is not available with the inverter.	-
Option Trip-2	Level	When the option gets out of the option slot No. 2 after it was inserted during power supply or when communication is not available with the inverter.	-
Option Trip-3	Level	When the option gets out of the option slot No. 3 after it was inserted during power supply or when communication is not available with the inverter.	-

7

Note) **Level** : automatically terminates when the failure is solved. This is not saved in the failure history.

Latch : terminates when the reset signals are input after the failure is solved.

Fatal : The failure state terminates when you cut the power supply to the inverter and then supply power again with the internal charging lamp is turned off after the failure is solved.

7.1.2 Alarm functions

Type	Description
Over Load	An alarm signal is released in case of overload to the motor. Operation resumes if you set PRT-17 at 1. If signals are necessary for the output contact point, No. 4 overload is selected among the functions of OUT31~33.
Under Load	Set PRT-25 at 1 if an alarm is necessary for an underload situation. As the output signal, No. 6 Under Load is selected among the functions of OUT31~33.
Inv Over Load	An alarm is released if time equal to 60% of the level at which the inverter IOLT functions is accumulated. As the output signal, No. 5 IOL is selected among the functions of OUT31~33.
Lost Command	An alarm signal can be released as well when PRT-12 Lost Cmd Mode is 0. The alarm is released in a certain condition between PRT13~15. As the output signal, No. 12 Lost Command is selected among the functions of OUT31~33.
Fan Warning	An alarm is released if a problem is detected with the cooling fan with PRT-79 FAN Trip Mode set at 1. As the output signal, No.8 Fan Warning is selected among the functions of OUT31~33.
DB Warn %ED	An alarm is released if the DB resistance consumption rate is above the prescribed degree. The detection level is set at PRT-66.
Enc Conn Check	An alarm is signified if No. 3 Enc Test is selected from BAS-20 Auto Tuning and no signal is input during the encoder test. Signals are released if ENC Tune is set among the functions of OUT31~33.
Enc Dir Check	An alarm is signified if No. 3 Enc Test is selected from BAS-20 Auto Tuning and the setting is wrongly changed between encoder phase A and B during the encoder test or the rotation direction is reverse. Signals are released if ENC Dir is set among the functions of OUT31~33.
Lost Keypad	An alarm is signified if the operating command is keypad or any problem is detected with the communication between the keypad and the main body of the inverter in Keypad JOG Mode with PRT-11 Lost KPD Mode set 0. As the output signal, No. 29 Lost Keypad is selected among the functions of OUT31~33.

7.1.3 Troubleshooting

Type	Cause of Trouble	Solution
Over Load	<ul style="list-style-type: none"> ■ The load is higher than the rated load of the motor. ■ The load set at the overload failure level (PRT-21) is small. 	<ul style="list-style-type: none"> ☞ Raise the capacity of the motor and inverter. ☞ Increase the set value.
Under Load	<ul style="list-style-type: none"> ■ There is a problem with the connection between the motor and load. ■ The underload level (PRT-29, 30) is lower than the minimum system load. 	<ul style="list-style-type: none"> ☞ Raise the capacity of the motor and inverter. ☞ Increase the set value.
Over Current1	<ul style="list-style-type: none"> ■ Acc/Dec time is too short compared with the inertia of the load (GD2). ■ The load of the inverter is bigger than its rated load. ■ Inverter output is ON during idling of the motor. ■ The braking of the motor is too fast. 	<ul style="list-style-type: none"> ☞ Raise the Acc/Dec time. ☞ Replace the inverter for one with bigger capacity. ☞ Operate the inverter after the motor stops or use speed search (CON-60). ☞ Check the machine brake.
Over Voltage	<ul style="list-style-type: none"> ■ Decelerating time is too short compared with the inertia of the load (GD2). ■ Regenerative load is located at the inverter output. ■ The supply voltage is too high. 	<ul style="list-style-type: none"> ☞ Set the decelerating time higher. ☞ Use a braking resistance device. ☞ Check whether the supply voltage is above the prescribed degree.
Low Voltage	<ul style="list-style-type: none"> ■ The supply voltage is too low. ■ Load larger than the power supply capacity is connected (a welder or motor direct on line). ■ Nonconformity of the electronic contactor, etc. on the power supply side. 	<ul style="list-style-type: none"> ☞ Check whether the supply voltage is below the prescribed degree. ☞ Raise the power supply capacity. ☞ Replace the electronic contactor.
Ground Trip	<ul style="list-style-type: none"> ■ Earth of the outlet cord of the inverter. ■ Deterioration of the insulation of the motor. 	<ul style="list-style-type: none"> ☞ Check the output terminal distribution of the inverter. ☞ Replace the motor.
E-Thermal	<ul style="list-style-type: none"> ■ The motor is overheated. ■ The load of the inverter is bigger than its rated load. ■ The electronic thermal level is set too low. 	<ul style="list-style-type: none"> ☞ Reduce the load or frequency. ☞ Raise the capacity of the inverter. ☞ Set the electronic thermal level properly.

Type	Cause of Trouble	Solution
	<ul style="list-style-type: none"> ■ The inverter has operated for a long time at a low speed. 	<ul style="list-style-type: none"> ☞ Replace the motor for one that can separately supply power to the cooling fan.
Out Phase Open	<ul style="list-style-type: none"> ■ Contact trouble of the electronic contactor of the output side. ■ Bad distribution of output 	<ul style="list-style-type: none"> ☞ Check the electronic contactor of the output side of the inverter. ☞ Check the output distribution.
In Phase Open	<ul style="list-style-type: none"> ■ Contact trouble of the electronic contactor of the input side ■ Bad distribution of input ■ The DC condenser of the inverter needs replacing. 	<ul style="list-style-type: none"> ☞ Check the electronic contactor of the input side of the inverter. ☞ Check the input distribution. ☞ You should replace the DC condenser of the inverter. Get customer service from an agency.
Inverter OLT	<ul style="list-style-type: none"> ■ The load of the inverter is bigger than it's the inverter rating. ■ Torque boost is too high. 	<ul style="list-style-type: none"> ☞ Raise the capacity of the inverter and motor. ☞ Reduce the torque boost amount.
Over Heat	<ul style="list-style-type: none"> ■ There is a problem with the cooling system. ■ The inverter has been used longer than the replacement cycle of the cooling fan. ■ The surrounding temperature is too high. 	<ul style="list-style-type: none"> ☞ Check whether there is any foreign substance in the vent, air duct or outlet. ☞ Replace the inverter cooling fan. ☞ Keep the temperature around the inverter below 50°C.
Over Current2	<ul style="list-style-type: none"> ■ Earth of the output cord of the inverter ■ There is a problem with the inverter power switch (IGBT). 	<ul style="list-style-type: none"> ☞ Check the output terminal distribution of the inverter. ☞ Inverter operation is impossible. Contact a near service provider.
NTC Open	<ul style="list-style-type: none"> ■ The surrounding temperature is out of the prescribed range. ■ There is a problem with the internal temperature sensor of the inverter. 	<ul style="list-style-type: none"> ☞ Keep the temperature around the inverter below the prescribed degree. ☞ Contact a near service provider.
FAN Trip	<ul style="list-style-type: none"> ■ There is foreign substance in the inverter vent where the fan is. ■ The cooling fan of the inverter needs replacing. 	<ul style="list-style-type: none"> ☞ Check the vent or air outlet. ☞ Replace the cooling fan of the inverter.
IP54 FAN Trip	<ul style="list-style-type: none"> ■ Internal fan connector is not connected. ■ Internal fan PCB board's power connector is not connected. ■ Inverter cooling fan become to change period time. 	<ul style="list-style-type: none"> ☞ Connect internal Fan connector. ☞ Internal fan PCB board's power connector is connected. ☞ Inverter cooling fan have to be changed.

7.1.4 Replacement of cooling fan

1) Replacement steps of the product below 7.5kW

Push the bracket on the bottom to the arrow direction and pull it forward. Disconnect the connector of the fan, then you can replace the fan.

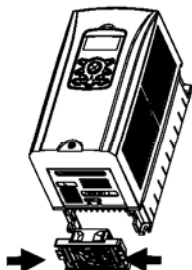

<below 3.7kW>

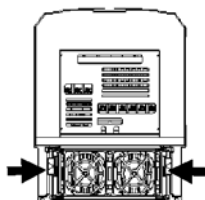

<below 7.5 kW>

2) Replacement steps of product of 11~15kW 200V/400V, 18.5~22 kW 400V

Release the volts under the In-Out put terminals and disconnect the connector of the fan, then you can replace the fan.

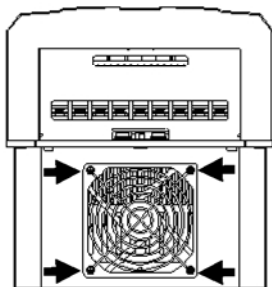

3) Replacement steps of product of 18.5~22 kW 200V, 30~75kW 200V/400V (Check capacity.) Release the volts upper of the product and disconnect the connector of the fan, then you can replace the fan.

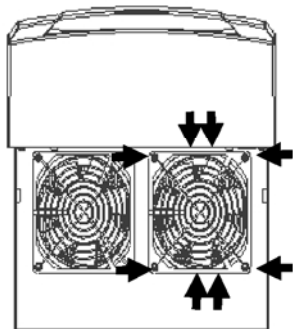

7.1.5 Daily and regular checkup list

Checkup Part	Checkup Items	Check up	Checkup cycle		Way of Checkup	Criterion decision	Counter-plan	
			daily	Regular (Year) 1 2				
Total	Environment	Check : temperature,umidity, dust, ETC.	0	-	-	See warning	No freezing under temperature of -10~+40. No dew under humidity of 50%	thermometer, hygrometer, recorder
	Entire devices	Is there any abnormal vibration or sound?	0	-	-	By seeing or hearing	if no matter	-
	Power Source Voltage	Normal or not of the Voltage of main circuit?	0	-	-	Voltage check among the terminal R, S, T phase of the inverter	-	Digital multimeter/ tester
Main circuit	Total	1) Megger check (between main circuit terminals and connecting terminals) 2) Are all of the fixed parts on the position? 3) Is there any evidences of overheating on each parts? 4) cleaning	-	0	0	1) Disconnect the inverter and short terminals R,S,T, U,V,W, and then measure these terminals and connecting terminals with Cycle megger 2) Screw up 3) Check by seeing.	1) over 5MΩ 2),3) no matter	DC 500V Megger
	Connected conductors /Wires	1)Is there any corrosion on the conductor 2) Is there any damage on coverings of the wire?	-	0	0	Check by seeing.	if no matter	-
	Terminals	Is there any damaged?	-	0	-	Check by seeing.	if no matter	-
	Intermediate Condenser	1) Is liquid leaking inside? 2) Is the safety apparatus on the position? Is there any protuberance? 3) Check the power failure capacity	0 0	0	-	1), 2) Check by seeing. 3) Check with Capacity meter	1),2) if no matter 3) 85% Over than Rated capacity	Capacity meter
	Relay	1) Is there any chattering sound under operation 2) Is there any damage on contact point?	-	0	-	1)check by hearing 2)check by seeing	if no matter	-
	Resistor	1) Is there any damage on isolating method of	-	0	-	1) check by seeing	1) if no matter	Digital multimeter/

Chapter 7 Checking and Troubleshooting

Checkup Part	Checkup items	Check up	Checkup cycle		Way of Checkup	Criterion decision	Counter-plan	
			daily	Regular (Year) 1 2				
		Resistor? 2) Check disconnection		0		2) Disconnect one side and check with the tester	2) within $\pm 10\%$ variation of indicated resistance value	Analogue tester
Control circuit Protective circuit	Operation checking	1) Check the imbalance of each output voltage during the operation.		0		1) Check the voltage of the Inverter output terminal among U,V,W	1) Voltage within phases: For balance 200V (400V) - within 4V(8V)	Digital multimeter/rectification voltmeter
		2) No abnormalities on the display circuit after executing sequence protection test	-	0	-	2) short or open the Inverter protection circuit by force.	2) Abnormal circuit is on the operation according to the sequence.	
Cooling system	Cooling fan	1) Is there any abnormal vibration or sound?	0			1) Turn it with hands under condition of power off	1) It turns smoothly	-
		2) Is there any laxness on the connecting parts?		0	-	2) Fasten it Again.	2) No Abnormality should be founded	
Display	Meter	Is the displayed value normal?	0	0	-	Check the displayed value on the surface of panel	Check the regulational and administrative value	Voltmeter /Amperemeter
Motor	Total	1) Is there any abnormal vibration or sound?	0			1) Check by ears, eyes and hands	No Abnormality should be founded	-
		2) Is there any abnormal smell?	0	-	-	2) Check the abnormality such as overheating, damage etc.		
	Isolation resistance	Megger check (Between the output terminal and connecting terminal)	-	-	0	Disconnect the connection of U,V,W and connect the motor wires.	Over 5M Ω	500V class Megger

8.1 Table of Functions

8.1.1 Parameter mode – DRV group(→DRV)

* The number of page is for User's manual uploaded at LSIS website. You can download the User's manual which is described detailed function of parameter from website. (<http://www.lsis.biz>)

Control mode abbreviation:
V/F: V/F (PG included), SL: Sensorless-1, 2, VC: Vector,
SLT: Sensorless-1, 2 Torque, VCT: Vector Torque

DRV Group (PAR → DRV)

No.	Communication No.	Function Display	Name	Setting Range	Initial Value	Shut In Operation	Page	Control Mode					
								V/F	SL	VC	SLT	VCT	
00	-	Jump Code	jump code	0-99	9	0	-	0	0	0	0	0	0
01	0h1101	Cmd Frequency	target frequency	0.0-maximum frequency(Hz)	0.0	0	7-1	0	0	0	X	X	
02	0h1102	Cmd Torque	torque command	-180-180[%]	0.0	0	8-31	X	X	X	0	0	
03	0h1103	Acc Time	accelerating time	0-600[sec]	Below 75kW 20.0 Above 90kW 60.0	0	7-16	0	0	0	0	0	
04	0h1104	Dec Time	decelerating time	0-600[sec]	Below 75kW 30.0 Above 90kW 90.0	0		0	0	0	0	0	
06	0h1106	Cmd Source	operating command method	0 Keypad 1 Fx/Rx-1 2 Fx/Rx-2 3 Int 485 4 Field Bus 5 PLC	1: Fx/Rx-1	X	7-11	0	0	0	0	0	
07	0h1107	Freq Ref Src	frequency setting method	0 Keypad-1	0: Keypad-1	X	7-1	0	0	0	X	X	
08	0h1108	Tiq Ref Src	torque command method	0 Keypad-1 1 Keypad-2 2 V1 3 I1 4 V2 5 I2 6 Int 485 7 Encoder 8 Field Bus 9 PLC	0: Keypad-1	X	8-32	X	X	X	0	0	
09 (New)	0h1109	Control Mode	control mode	0 V/F 1 V/F PG 2 Slip Compn 3 Sensorless-1 4 Sensorless-2 5 Vector	0: V/F	X	7-20 8-20 8-11 8-21 8-23 8-31	0	0	0	0	0	

* The grey code refers to hidden code, emerging only in case of setting of the code.

Note 1) Effectiveness of each code according to the Control Mode setting

Refer to Option manual for options.

Chapter 8 Table of Functions

DRV Group (PAR → DRV)

No.	Communication No.	Function Display	Name	Setting Range	Initial Value	Still in Operation	Page	Control Mode				
								V / F	S L	V C	S L T	V C T
10	Oh110A	Torque Control	torque control	0 No 1 Yes	0: No	X	8-31	X	X	X	0	0
11	Oh110B	Jog Frequency	jog frequency	0.5-maximum frequency[Hz]	10.00	0	8-4	0	0	0	0	0
12	Oh110C	Jog Acc Time	jog operation Acc time	0-600[sec]	20.0	0		0	0	0	0	0
13	Oh110D	Jog Dec Time	jog operation Dec time	0-600[sec]	30.0	0		0	0	0	X	X
14	Oh110E	Motor Capacity	motor capacity	0:0.2kW, 10.4kW 20.75kW, 31.5kW 42.2kW, 53.7kW 65.5kW, 77.5kW 81.1kW, 91.9kW 101.8kW, 112.2kW 123.0kW, 133.7kW 144.9kW, 155.6kW 167.9kW, 179.0kW 181.1kW, 193.2kW 201.6kW, 211.8kW	depends on inverter capacity	X	8-17	0	0	0	0	0
15	Oh110F	Torque Boost	torque boost method	0 Manual 1 Auto	0:Manual	X	7-22	0	X	X	X	X
16 Note2)	Oh1110	Fwd Boost	forward torque boost	0-15[%]	Below 75kW 2.0 Above 90kW 1.0	X	7-22	0	X	X	X	X
17	Oh1111	Rev Boost	reverse torque boost		Below 75kW 2.0 Above 90kW 1.0	X		0	X	X	X	X
18	Oh1112	Base Freq	base frequency	30-400[Hz]	60.00	X	7-20	0	0	0	0	0
19	Oh1113	Start Freq	starting frequency	0.01-100[Hz]	0.50	X		0	X	X	X	X
20	Oh1114	Max Freq	maximum frequency	40-400	60.00	X	7-26	0	0	0	0	0
21	Oh1115	Hz/Rpm Sel	speed unit selection	0 Hz Display 1 Rpm Display	0:Hz	0	9-3	0	0	0	0	0

*  The grey code refers to hidden code, emerging only in case of setting of the code.

Note 2) DRV-16-17 code is displayed only when DRV-15 (Torque Boost) code value is "Manual".

8.1.2 Parameter mode – Basic function group (→BAS)

BAS Group(PAR → BAS)

No.	Communication No.	Function Display	Name	Setting Range	Initial Value	Stk'n Operation	Page	Control Mode				
								V / F	S L	V C	S L T	V C T
00	-	Jump Code	Jump code	0-99	20	0	-	0	0	0	0	0
01	0h1201	Aux Ref Src	auxiliary command Setting method	0 None	0/None	X	8-1	0	0	0	X	X
				1 V1								
				2 H								
				3 V2								
				4 I2								
02 <small>Note 3)</small>	0h1202	Aux Calc Type	auxiliary command Movement selection	0 M*(G*A)	0: M*(G*A)	X	8-1	0	0	0	X	X
				1 M*(G*A)								
				2 M*(G*A)								
				3 M*(M*2(G*A))								
				4 M*(G*2(A-50%))								
				5 M*(G*2(A-50%))								
				6 M*(G*2(A-50%))								
				7 M*(M*G*2(A-50%))								
03	0h1203	Aux Ref Gain	auxiliary command gain	-200.0-200.0[%]	100.0	0	8-2	0	0	0	X	X
04	0h1204	Cnd 2nd Src	2nd operation command method	0 Keypad	1: Fx/Rx-1	X	7-28	0	0	0	0	0
				1 Fx/Rx-1								
				2 Fx/Rx-2								
				3 Int 485								
				4 FieldBus								
				5 PLC								
05	0h1205	Freq 2nd Src	2nd frequency Setting method	0 Keypad-1	0: Keypad-1	0		0	0	0	X	X

* The grey code refers to hidden code, emerging only in case of setting of the code.

Note 3) BAS-02 code is displayed only when BAS-01 (Aux Ref Src) code has a value other than "NONE".

Chapter 8 Table of Functions

BAS Group (PAR → BAS)

No.	Communication No.	Function Display	Name	Setting Range	Initial Value	Shift in Operation	Page	Control Mode					
								V / F	S L	V C	S L T	V C T	
06	0h1206	Trq 2nd Src	2 nd torque command method	1	Keypad-2	0: Keypad-1	O	7-28	X	X	X	O	O
				2	V1								
				3	I1								
				4	V2								
				5	I2								
				6	Int.485								
				7	Encoder								
				8	FieldBus								
				9	PLC								
				10	Synchro								
				11	Binary Type								
				12	Keypad-2								
07	0h1207	V/F Pattern	V/F pattern	0	Linear	0: Linear	X	7-21	O	O	X	X	X
				1	Square								
				2	User V/F								
				3	Square2								
08	0h1208	Ramp/T Mode	Acc/Dec standard frequency	0	Max Freq	0: Max Freq	X	7-15	O	O	O	X	X
				1	Delta Freq								
09	0h1209	Time Scale	time unit setting	0	0.01sec	1: 0.1sec	X	7-16	O	O	O	X	X
				1	0.1sec								
				2	1sec								
10	0h120A	6050 Hz Sel	input power frequency	0	60Hz	0: 60Hz	X	8-43	O	O	O	O	O
				1	50Hz								
11	0h120B	Pole Number	motor pole	2-48									
12	0h120C	Rated Slip	rated sleep speed	0-3000[rpm]		it depends on inverter capacity							
13	0h120D	Rated Curr	motor rated current	1-200[A]									
14	0h120E	No-load Curr	motor no load current	0.5-200[A]			8-11						
15	0h120F	Rated Volt	motor rated voltage	180-480[V]	0								
16	0h1210	Efficiency	motor efficiency	70-130[%]									
17	0h1211	Inertia Rate	load inertia ratio	0-8		it depends on inverter capacity							
18	0h1212	Trim Power %	Power display adjustment	70-130[%]			9-2						
19	0h1213	AC Input Volt	input power voltage	170-230V	220V	O	8-43	O	O	O	O	O	O
				320-480V	440V / 380								
20	-	Auto Tuning	auto tuning	0	None	0: None	X	8-18	X	O	O	O	O
				1	All								
				2	ALL(Sbstl)								
				3	Rs+Sigma								
				4	Enc Test								
				5	Tr								
6	Tr(Sbstl)												

BAS Group (PAR → BAS)

No.	Communication No.	Function Display	Name	Setting Range	Initial Value	Still in Operation	Page	Control Mode				
								V/F	S/L	V/C	S/L/T	V/C/T
21	-	Rs	stator resistance	It depends on motor	-	X	8-19	X	0	0	0	0
22	-	Lsigma	leak inductance		-	X		X	0	0	0	0
23	-	Ls	stator inductance		-	X		X	0	0	0	0
24 (hid)	-	Tr	rotor time constant	25-5000[msec]	-	X	8-19	X	0	0	0	0
41 (hid)	0h1229	User Freq 1	user frequency 1	0-maximum frequency[Hz]	15.00	X	7-21	0	X	X	X	X
42	0h122A	User Vol1	user voltage 1	0-100[%]	25	X		0	X	X	X	X
43	0h122B	User Freq 2	user frequency 2	0-maximum frequency[Hz]	30.00	X		0	X	X	X	X
44	0h122C	User Vol2	user voltage 2	0-100[%]	50	X		0	X	X	X	X
45	0h122D	User Freq 3	user frequency 3	0-maximum frequency[Hz]	45.00	X		0	X	X	X	X
46	0h122E	User Vol3	user voltage 3	0-100[%]	75	X		0	X	X	X	X
47	0h122F	User Freq 4	user frequency 4	0-maximum frequency[Hz]	60.00	X		0	X	X	X	X
48	0h1230	User Vol4	user voltage 4	0-100[%]	100	X		0	X	X	X	X
50 (hid)	0h1232	Step Freq-1	sequential frequency 1	0-maximum frequency[Hz]	10.00	0	7-9	0	0	0	X	X
51	0h1233	Step Freq-2	sequential frequency 2		20.00	0		0	0	0	X	X
52	0h1234	Step Freq-3	sequential frequency 3		30.00	0		0	0	0	X	X
53	0h1235	Step Freq-4	sequential frequency 4		40.00	0		0	0	0	X	X
54	0h1236	Step Freq-5	sequential frequency 5		50.00	0		0	0	0	X	X
55	0h1237	Step Freq-6	sequential frequency 6		60.00	0		0	0	0	X	X
56	0h1238	Step Freq-7	sequential frequency 7		60.00	0		0	0	0	X	X
57	0h1239	Step Freq-8	sequential frequency 8		55.00	0		0	0	0	X	X
58	0h123A	Step Freq-9	sequential frequency 9		50.00	0		0	0	0	X	X
59	0h123B	Step Freq-10	sequential frequency 10		45.00	0		0	0	0	X	X
60	0h123C	Step Freq-11	sequential frequency 11		40.00	0		0	0	0	X	X
61	0h123D	Step Freq-12	sequential frequency 12		35.00	0		0	0	0	X	X
62	0h123E	Step Freq-13	sequential frequency 13		25.00	0		0	0	0	X	X
63	0h123F	Step Freq-14	sequential frequency 14		15.00	0		0	0	0	X	X
64	0h1240	Step Freq-15	sequential frequency 15		5.00	0		0	0	0	X	X
70	0h1246	Acc Time-1	sequential accelerating time 1	0-600[sec]	20.0	0	7-17	0	0	0	X	X
71	0h1247	Dec Time-1	sequential decelerating time 1		20.0	0		0	0	0	X	X
72 (hid)	0h1248	Acc Time-2	sequential accelerating time 2		30.0	0		0	0	0	X	X
73	0h1249	Dec Time-2	sequential decelerating time 2	0-600[sec]	30.0	0	7-17	0	0	0	X	X
74	0h124A	Acc Time-3	sequential accelerating time 3		40.0	0		0	0	0	X	X
75	0h124B	Dec Time-3	sequential decelerating time 3		40.0	0		0	0	0	X	X

*  The grey code refers to hidden code, emerging only in case of setting of the code.

Note 4) BAS-24 is shown only when DRV-09 Control Mode is set as "Sensorless-2" or "Vector".

Note 5) BAS-41-48 is displayed only when it is set as "User V/F" even if there is only one BAS-07 or M2-V/F Patt (M2-25).

Note 6) BAS-50-64 is displayed only when it is set as "sequential" (Speed -L.M.H,X) even if there is only one multi-function input of IN-65-75.

Note 7) BAS-72-75 is displayed only when it is set as "sequential Acc/Dec" (Xcel-L,M,H) even if there is only one multi-function input of IN-72-75.

8.1.3 Parameter mode –Extended function group (PAR→ADV)

Extended Function Group (PAR → ADV)

No.	Communication No.	Function Display	Name	Setting Range	Initial Value	Still in Operation	Page	Control Mode				
								V/F	S/L	V/C	S/L/T	V/C/T
00	-	Jump Code	jump code	0-99	24	0	-	0	0	0	0	0
01	Oh1301	Acc Pattern	accelerating pattern	0 Linear	0:U-near	X	7-18	0	0	0	X	X
02	Oh1302	Dec Pattern	decelerating pattern	1 S-curve		X		0	0	0	X	X
03	Oh1303	Acc S Start	S accelerating starting slope	1~100[%]	40	X		0	0	0	X	X
04	Oh1304	Acc S End	S accelerating end slope			X		0	0	0	X	X
05	Oh1305	Dec S Start	S decelerating starting slope			X		0	0	0	X	X
06	Oh1306	Dec S End	S decelerating end slope			X		0	0	0	X	X
07	Oh1307	Start Mode	starting method	0 Acc 1 Do-Start	0: Acc	X	7-24	0	0	0	X	X
08	Oh1308	Stop Mode	stop method	0 Dec 1 Do-Brake	0: Dec	X	7-25	0	0	0	X	X
				2 Free-Run 3 Reserved								
				4 Power Braking								
				0 None 1 Forward Prev 2 Reverse Prev								
				0 No 1 Yes								
09	Oh1309	Run Prevent	rotation preventing direction selection	0 None 1 Forward Prev 2 Reverse Prev	0: None	X	7-14	0	0	0	X	X
10	Oh130A	Power-on Run	power input starting	0 No 1 Yes	0:No	0	7-14	0	0	0	X	X
12 <small>Note 8)</small>	Oh130C	Do-Start Time	starting DC braking time	0-60[sec]	0.00	X	7-24	0	0	0	X	X
13	Oh130D	DC In Level	DC supply	0-200[%]	50	X	7-24	0	0	0	X	X
14 <small>Note 8)</small>	Oh130E	Do-Block Time	Pre-DC braking output block time	0-60[sec]	0.10	X	7-25	0	0	0	X	X
15	Oh130F	Do-Brake Time	DC braking time		1.00	X		0	0	0	X	X
16	Oh1310	Do-Brake Level	DC braking	0-200[%]	50	X		0	0	0	X	X
17	Oh1311	Do-Brake Freq	DC braking frequency	starting frequency-60[Hz]	5.00	X		0	0	0	X	X
20	Oh1314	Acc Dwell Freq	Accelerating dwell frequency	Starting frequency ~maximum frequency[Hz]	5.00	X		8-9	0	0	0	X
21	Oh1315	Acc Dwell Time	Accelerating dwell operation time	0-60.0[sec]	0.00	X	0		0	0	X	X
22	Oh1316	Dec Dwell Freq	Decelerating dwell frequency	Starting frequency ~maximum frequency[Hz]	5.00	X	0		0	0	X	X
23	Oh1317	Dec Dwell Time	Decelerating dwell operation time	0-60.0[sec]	0.00	X	0		0	0	X	X

* The grey code refers to hidden code, emerging only in case of setting of the code.

Note 8) ADV-12 is displayed only when ADV-07 "Stop Mode" is set as "Do-Start".

Note 9) ADV-14~17 is displayed only when ADV-08 "Stop Mode" is set as "DC-Brake".

Extended Function Group (PAR → ADV)

No.	Communication No.	Function Display	Name	Setting Range	Initial Value	Shut in Operation	Page	Control Mode					
								V / F	S / L	V / L	S / T	V / T	
24	0h1318	Freq Limit	frequency limit	0	No	0/No	X	7-27	0	0	0	X	X
				1	Yes								
25 <small>Note 10)</small>	0h1319	Freq Limit Lo	frequency lower limit	0-upper limit[Hz]	0.50	0	7-27	0	0	0	X	X	
26	0h131A	Freq Limit Hi	frequency upper limit	0.5-maximum frequency[Hz]	60.00	X		0	0	0	X	X	
27	0h131B	Jump Freq	frequency jump	0	No	0/No	X	7-27	0	0	0	X	X
				1	Yes								
28 <small>Note 11)</small>	0h131C	Jump Lo 1	jump frequency lower limit 1	0-jump frequency upper limit1[Hz]	10.00	0	7-27	0	0	0	X	X	
29	0h131D	Jump Hi 1	jump frequency upper limit 1	Jump frequency lower limit1-maximum frequency[Hz]	15.00	0		0	0	0	X	X	
30	0h131E	Jump Lo 2	jump frequency lower limit 2	0-jump frequency upper limit2[Hz]	20.00	0		0	0	0	X	X	
31	0h131F	Jump Hi 2	jump frequency upper limit 2	Jump frequency lower limit2-maximum frequency[Hz]	25.00	0		0	0	0	X	X	
32	0h1320	Jump Lo 3	jump frequency lower limit 3	0-jump frequency upper limit3[Hz]	30.00	0		0	0	0	X	X	
33	0h1321	Jump Hi 3	jump frequency upper limit 3	Jump frequency lower limit3-maximum frequency[Hz]	35.00	0		0	0	0	X	X	
41 <small>Note 12)</small>	0h1329	BR Rls Curr	brake open current	0-180.0[%]	50.0	0	8-52	0	0	0	X	X	
42	0h132A	BR Rls Dly	brake open delay time	0-10.00[sec]	1.00	X		0	0	0	X	X	
44	0h132C	BR Rls Fwd Fr	brake open forward frequency	0-maximum frequency[Hz]	1.00	X		0	0	0	X	X	
45	0h132D	BR Rls Rev Fr	brake open reverse frequency		1.00	X		0	0	0	X	X	
46	0h132E	BR Eng Dly	brake close delay time	0-10[sec]	1.00	X		0	0	0	X	X	
47	0h132F	BR Eng Fr	brake close frequency	0-maximum frequency[Hz]	2.00	X		0	0	0	X	X	
50	0h1332	E-Save Mode	energy saving operation	0	None	0/None	X	8-34	0	0	X	X	X
				1	Manual								
				2	Auto								
51 <small>Note 13)</small>	0h1333	Energy Save	energy saving amount	0-30[%]	0	0	8-34	0	0	0	X	X	
60	0h133C	Xcl Change Fr	AccDec time exchange frequency	0-maximum frequency[Hz]	0.00	X	7-17	0	0	0	X	X	

* The grey code refers to hidden code, emerging only in case of setting of the code.

Note 10) ADV-25~26 is displayed only when ADV-24 (Freq Limit) is set as "Freq Limit".

Note 11) ADV-28~33 is displayed only when ADV-27 (Jump Freq) is set as "Yes".

Note 12) ADV-41~47 is displayed only when a code of OUT-31~33 is set as "BR Control".

Note 13) ADV-51 is displayed only when ADV-50 (E-Save Mode) is set as values other than "None".

Chapter 8 Table of Functions

Extended function Group (PAR → ADV)

No.	Communication No.	Function Display	Name	Setting Range	Initial Value	Shift in Operation	Page	Control Mode					
								V/F	S/L	V/C	S/L	V/C	
61	-	Load Spd Gain	revolution display gain	1-6000.0[%]	100.0	0		0	0	0	X	X	
62	-	Load Spd Scale	revolution display scale	0	x1	0x1	0	93	0	0	0	X	X
				1	x0.1								
				2	x0.01								
				3	x0.001								
				4	x0.0001								
63	0h133F	Load Spd Unit	revolution display unit	0	rpm	0rpm	0		0	0	0	0	0
				1	mpm								
64	0h1340	FAN Control	cooling fan control	0	During Run	0: During Run	0	8-42	0	0	0	X	X
				1	Always ON								
				2	Temp Control								
65	0h1341	UID Save Mode	updown Operation frequency saving	0	No	0: No	0	8-6	0	0	0	X	X
				1	Yes								
66	0h1342	On/Off Cnt Src	-	0	None	0: None	X	8-55	0	0	0	0	0
				1	V1								
				2	I1								
				3	V2								
				4	I2								
67	0h1343	On-C Level	Output contact point ON level	10~100[%]	90.00	X		0	0	0	0	0	
68	0h1344	Off-C Level	Output contact point OFF level	-100.00~output contact point ON level [%]	10.00	X		0	0	0	0	0	
70	0h1346	Run En Mode	safety operation selection	0	Always Enable	0: Always Enable	X	8-8	0	0	0	0	0
				1	DI Dependent								
71 <small>Note4)</small>	0h1347	Run Dis Stop	safety operation stop method	0	Free-Run	0: Free-Run	X	8-8	0	0	0	0	0
				1	Q-Stop								
				2	Q-Stop Resume								
74	0h134A	RegenAvt Sel	Selection of regeneration and avoidance function for press	0	No	No	X	8-60	0	0	0	0	0
				1	Yes								
75	0h134B	RegenAvt Level	Operational Voltage level of regeneration and avoidance for press	200V: 300~400	350V	X	8-60	0	0	0	X	X	
				400V: 600~800	700V								
76 <small>Note5)</small>	0h134C	CompFreq Limit	Restriction of compensational frequency of regeneration and avoidance for press	0~ 10.00Hz	1.00[Hz]	X	8-60	0	0	0	X	X	

No.	Communication No.	Function Display	Name	Setting Range	Initial Value	Shift in Operation	Page	Control Mode				
								V / F	S L	S L C	V L T	S L T
77	0h134D	RegenAvd Pgain	P-gain of regeneration and avoidance for press	0~100.0%	50.0[%]	0	8-80	0	0	0	X	X
78	0h134E	RegenAvd Igain	I-gain of regeneration and avoidance for press	20~30000[msec]	500[msec]	0		0	0	0	X	X

* The grey code refers to hidden code, emerging only in case of setting of the code.

Note 14) ADV-71~72 is displayed only when ADV-70 (Run En Mode) is set as "DI Dependent".

Note 15) ADV-76~78 is displayed only when ADV-75 (RegenAvd Sel) is set as "Yes".

Chapter 8 Table of Functions

8.1.4 Parameter mode – Control function group (→CON)

Control Function Group (PAR → CON)

No.	Communication No.	Function Display	Name	Setting Range	Initial Value	Shift in Operation	Page	Control Mode					
								V / F	S / L	V / L	S / T	V / T	
00	-	Jump Code	jump code	0-99	51	0	-	0	0	0	0	0	0
04	0h1404	Carrier Freq	carrier frequency	Below 2kW	0.7-15[kHz]	5.0	0	8-38	0	0	0	0	0
				30-45kW	0.7-10[kHz]	5.0							
				55-75kW	0.7-7[kHz]	5.0							
				90-110kW	0.7-6[kHz]	3.0							
				132-160kW	0.7-5[kHz]	3.0							
05	0h1405	PWM Mode	switching mode	0	Normal PWM	0 : Normal PWM	X	8-38	0	0	0	0	0
				1	Lowleakage PWM								
09	0h1409	PreExTime	initial flux time	0-60[sec]	1.00	X	8-27	X	X	0	0	0	0
10	0h140A	Flux Force	initial flux power supply	100-500[%]	100.0	X		X	X	0	0	0	0
11	0h140B	Hold Time	permanent operation sustaining time	0-60[sec]	1.00	X		X	X	0	X	X	X
12	0h140C	ASR P Gain 1	speed control period proportionalgain1	10-500[%]	50.0	0		X	X	0	X	X	X
13	0h140D	ASR I Gain 1	speed control period integral calculus gain 1	10-9999[msec]	300	0		X	X	0	X	X	X
15	0h140F	ASR P Gain 2	speed control period proportionalgain2	1-500[%]	50.0	0		X	X	0	X	X	X
16	0h1410	ASR I Gain 2	speed control period integral calculusgain2	10-9999[msec]	300	0		X	X	0	X	X	X
18	0h1412	Gain SW Freq	gain exchange frequency	0-120[Hz]	0.00	X		X	X	0	X	X	X
19	0h1413	Gain Sw Delay	gain exchange time	0-100[sec]	0.10	X		X	X	0	X	X	X
20	0h1414	SL2 G View Sel	sensorless 2 nd gain display setting	0	No	0: No		0	8-23	X	X	X	X
				1	Yes								
21	0h1415	ASR-SL P Gain1	sensorless 1,2 speed control period proportionalgain1	0-5000[%]	Depends on motor capacity	0	8-23	X	0	X	X	X	X
22	0h1416	ASR-SL I Gain1	sensorless 1,2 speed control period integral calculusgain1	10-9999[msec]		0		X	0	X	X	X	X
23 New 19	0h1417	ASR-SL P Gain2	sensorless 2 speed control period proportionalgain2	1-1000[%]	Depends on motor capacity	0	8-23	X	X	X	X	X	X
						0		X	X	X	X	X	
24	0h1418	ASR-SL I Gain2	sensorless 2 speed control period integral calculusgain2			0	X	X	X	X	X	X	
26	0h141A	Observer Gain1	sensorless 2 measurer gain1	0-30000	10500	0	X	X	X	X	X	X	

No.	Communication No.	Function Display	Name	Setting Range	Initial Value	Shift in Operation	Page	Control Mode				
								V / F	S / L	V / C	S / L / T	V / C / T
27	0h141B	Observer Gain2	sensorless2 measurer gain2	1~1000[%]	100.0	0	8-23	X	X	X	X	X
28	0h141C	Observer Gain3	sensorless2 measurer gain3	0~30000	13000	0		X	X	X	X	X
29	0h141D	S-Est P Gain1	sensorless2 speed estimator proportionalgain1	0~30000	Depends on motor capacity	0	8-23	X	X	X	X	X
30	0h141E	S-Est I Gain1	sensorless2 speed estimator integral calculsgain1			0		X	X	X	X	X

* The grey code refers to hidden code, emerging only in case of setting of the code.

Note 16) CON-23~28, 31~32 are displayed only when DRV-09 (Control Mode) is "Sensorless2" and CON-20 (SL2 G View Sel) is set as "YES".

Chapter 8 Table of Functions

Control Function Group (PAR → CON)

No.	Communication No.	Function Display	Name	Setting Range	Initial Value	Shift in Operation	Page	Control Mode				
								V/F	S/L	V/C	S/L/T	V/C/T
31	0h141F	S-Est P Gain2	Sensorless2 speed estimator proportional gain2	1~1000[%]	Depends on motor capacity	0	8-23	X	X	X	X	X
32	0h1420	S-Est I Gain2	Sensorless2 speed estimator integral calculus gain2		0	X		X	X	X	X	
34	0h1422	SL2 OVM Perc	Sensorless2 overvoltage modulation range adjustment	100~180[%]	120	X	8-25	X	0	X	X	X
45 <small>(Not 7)</small>	0h142D	PG P Gain	PG operation proportional gain	0~9999	3000	0	8-20	0	X	X	X	X
46	0h142E	PG I Gain	PG operation integral calculus gain		50	0		0	X	X	X	X
47	0h142F	PG Slip Max%	PG operation maximum sleep		0~200	100		X	0	X	X	X
48	-	ACR P Gain	Current control period P gain	0~10000	1200	0	8-23	X	0	0	0	0
49	-	ACR I Gain	Current control period I gain		120	0		X	0	0	0	0
51	0h1433	ASR Ref LPF	speed control period reference filter	0~20000[msec]	0	X	8-27	X	0	0	X	X
52	0h1434	Torque Out LPF	Torque control period Output filter	0~2000[msec]	0	X		X	X	X	0	0
53	0h1435	Torque Lmt Src	Torque limit Setting method	0 Key-pad-1 1 Key-pad-2 2 V1 3 H 4 V2 5 I2 6 Int485 7 Encoder 8 FieldBus 9 PLC 10 Synchro 11 Binary Type	0:Key-pad-1	X		X	X	X	0	0
54 <small>(Not 9)</small>	0h1436	FWD +Trq Lmt	forward offsetting Torque limit	0~200[%]	180.0	0	8-27	X	X	X	0	0
55	0h1437	FWD -Trq Lmt	forward regenerative torque limit			0		X	X	X	0	0
56	0h1438	REV +Trq Lmt	reverse offsetting torque limit			0		X	X	X	0	0
57	0h1439	REV -Trq Lmt	reverse regenerative torque limit			0		X	X	X	0	0

* The grey code refers to hidden code, emerging only in case of setting of the code.

Note 17) CON-45~47 are displayed when Encoder Board is inserted and Control mode is V/F PG.

Note 18) CON-54~57 are displayed only when DRV-09(Control Mode) is set as "Sensorless-1, 2" or "Vector". The initial value of torque limit will be changed to 150% with the setting of ADV-74.

Control Function Group (PAR → CON)

No.	Communication No.	Function Display	Name	Setting Range	Initial Value	Shut In Operation	Page	1) Control Mode					
								V / F	S / L	V / C	S / T	V / C	
58	0h143A	Trq Bias Src	torque bias setting method	0	Keypad-1	0/Keypad-1	X	8-27	X	X	O	X	X
				1	Keypad-2								
				2	V1								
				3	H								
				4	V2								
				5	I2								
				6	Int-485								
				7	FieldBus								
8	PLC												
59	0h143B	Torque Bias	torque bias	-120~120[%]	0.0	0		X	X	O	X	X	
60	0h143C	Torque Bias FF	torque bias compensation	0~100[%]	0.0	0		X	X	O	X	X	
62	0h143D	Speed Lmt Src	Speed limit setting method	0	Keypad-1	0/Keypad-1	0	8-31	X	X	X	X	O
				1	Keypad-2								
				2	V1								
				3	H								
				4	V2								
				5	I2								
				6	Int-485								
				7	FieldBus								
8	PLC												
63	0h143F	FWD Speed Lmt	forward speed limit	0-maximum frequency[Hz]	60.00	0		X	X	X	X	O	
64	0h1440	REV Speed Lmt	reverse speed limit		60.00	0		X	X	X	X	O	
65	0h1441	Speed Lmt Gain	Speed limit operation gain	100~5000[%]	500	0		X	X	X	X	O	
66	0h1442	Droop Perc	droop operation amount	0~100[%]	0.0	0		X	X	X	X	O	
67 Hidden	0h1443	Droop St Trq	droop start torque	0~100[%]	100.0	0		X	X	X	X	O	
68	0h1444	SPD/TRQ Acc T	torque mode→speed mode exchange accelerating time	0~600[sec]	20.0	0	8-33	X	X	X	X	O	
69	0h1445	SPD/TRQ Acc T	torque mode→speed mode exchange decelerating time		30.0	0							

* The grey code refers to hidden code, emerging only in case of setting of the code.

Note 19) CON-67 is displayed only when Encoder option board is mounted.

Chapter 8 Table of Functions

Control Function Group (PAR → CON)

No.	Communicati on No.	Function Display	Name	Setting Range	Initial Value	Shift in Operation	Page	① Control Mode				
								V / F	S L	V C	S L T	V C T
70	0h1446	SS Mode	Speed search mode selection	0 Flying Start-1 1 Flying Start-2	0	X	-	0	0	0	X	X
71	0h1447	Speed Search	Speed search operation selection	Bit 0000-1111 1 accelerating speed search selection 2 Reset start after trip 3 Re-start after instantaneous interruption 4 Start immediately after power ON	0000	X		0	0	0	X	X
72	0h1448	SS Sup-Current	speed search standard current	80-200[%]	Below 75kW 150 Above 90kW 100	0	8-35	0	0	X	X	X
73	0h1449	SS P-Gain	speed search proportional gain	0-9999	100	0		0	0	X	X	X
74	0h144A	SS I-Gain	speed search integral calculus gain	0-9999	200	0		0	0	X	X	X
75	0h144B	SS Block Time	Pre-speed search output block time	0-60[sec]	1.0	X		0	0	X	X	X
77	0h144D	KEB Select	energy buffering selection	0 No 1 Yes	0/No	X		8-34	0	0	0	X
78 Note 2)	0h144E	KEB Start Lev	energy buffering start amount	110-140[%]	125.0	X	8-34	0	0	0	X	X
79	0h144F	KEB Stop Lev	energy buffering stop amount	125-145[%]	130.0	X		0	0	0	X	X
80	0h1450	KEB Gain	energy buffering gain	1-20000	1000	0		0	0	0	X	X
82 Note 1)	0h1452	ZSD Frequency	permanent detection frequency	0-10[Hz]	2.00	0	9-12	X	X	0	X	0
83	0h1453	ZSD Band	permanent detection frequency band	0-2[Hz]	1.00	0		X	X	0	X	0

* The grey code refers to hidden code, emerging only in case of setting of the code.

Note 2) CON-78~80 are displayed only when CON-77 (KEB Select) is set as "Yes".

Note 1) CON-82~83 are displayed only when DRV-09 (Control Mode) is set as "Vector".

8.1.5 Parameter mode – Input terminal block function group (→IN)

Input Terminal Block Function Group (PAR → IN)

No.	Communication No.	Function Display	Name	Setting Range	Initial Value	Still in Operation	Page	Control Mode					
								V / F	S L	V L C	S L T	V C T	
00	-	Jump Code	jump code	0-99	65	0	-	0	0	0	0	0	0
01	0h1501	Freq at 100%	Analog maximum input frequency	Starting frequency- maximum frequency(Hz)	60.00	0	7-2	0	0	0	X	X	
02	0h1502	Torque at 100%	Analog maximum input torque	0-200(%)	100.0	0		X	X	0	0	0	0
05	0h1505	V1 Monitor[V]	V1 input amount display	0-10[V]	0.00	0		0	0	0	0	0	0
06	0h1506	V1 Polarity	V1 input polar selection	0 Unipolar 1 Bipolar	0: Unipolar	X		0	0	0	0	0	0
07	0h1507	V1 Filter	V1 input filter time constant	0 ~10000[msec]	10	0		0	0	0	0	0	0
08	0h1508	V1 Voltx1	V1 input minimum voltage	0-10[V]	0.00	0		0	0	0	0	0	0
09	0h1509	V1 Percy1	V1 minimum voltage output %	0-100(%)	0.00	0		0	0	0	0	0	0
10	0h150A	V1 Voltx2	V1 input maximum voltage	0-10[V]	10.00	0		0	0	0	0	0	0
11	0h150B	V1 Percy2	V1 maximum voltage output %	0-100(%)	100.00	0		0	0	0	0	0	0
12 Note 2)	0h150C	V1 (-)Voltx1	V1(-)input minimum voltage	-10-0[V]	0.00	0		7-4	0	0	0	0	0
13	0h150D	V1(-)Percy1	V1(-)minimum voltage output %	-100-0(%)	0.00	0			0	0	0	0	0
14	0h150E	V1(-)Voltx2	V1(-)input maximum voltage	-10-0[V]	-10.00	0	0		0	0	0	0	
15	0h150F	V1(-)Percy2	V1(-)maximum voltage output %	-100-0(%)	-100.00	0	0		0	0	0	0	
16	0h1510	V1 Inverting	rotation direction change	0 No 1 Yes	0: No	0	7-2	0	0	0	0	0	
17	0h1511	V1 Quantizing	V1 quantization level	0.04-10(%)	0.04	X		0	0	0	0	0	
20	0h1514	I1 Monitor[mA]	I1 input amount display	0-20[mA]	0.00	0	7-6	0	0	0	0	0	
22	0h1516	I1 Filter	I1 input filter time constant	0 ~10000[msec]	10	0		0	0	0	0	0	
23	0h1517	I1 Currx1	I1 input minimum current	0-20[mA]	4.00	0		0	0	0	0	0	
24	0h1518	I1 Percy1	Output at I1 minimum current %	0-100(%)	0.00	0		0	0	0	0	0	
25	0h1519	I1 Currx2	I1 input maximum current	4-20[mA]	20.00	0		0	0	0	0	0	
26	0h151A	I1 Percy2	Output at I1 maximum current	0-100(%)	100.00	0		0	0	0	0	0	
31	0h151F	I1 Inverting	rotation direction change	0 No 1 Yes	0: No	0		0	0	0	0	0	
32	0h1520	I1 Quantizing	I1 quantization level	0.04-10(%)	0.04	0	0	0	0	0	0		

Note 2) IN-12~15 codes are displayed only when IN-06 (V1 Polarity) is set as "Bipolar".

Chapter 8 Table of Functions

Input Terminal Block Function Group (PAR → IN)

No.	Communication No.	Function Display	Name	Setting Range	Initial Value	Shift in Operation	Page	Control Mode					
								V / F	S L	V C	S L T	V C T	
35 <small>Note 2)</small>	0h1523	V2 Monitor[V]	V2 input amount display	0-10[V]	0.00	0	7-7	0	0	0	0	0	
36	0h1524	V2 Polarity	V1 input polarity selection	0 Unipolar 1 Bipolar	t: Bipolar	0		0	0	0	0	0	
37	0h1525	V2 Filter	V2 input filter time constant	0-10000 [msec]	10	0		0	0	0	0	0	
38	0h1526	V2 Voltx1	V2input minimum voltage	0-10[V]	0.00	0		X	X	0	0	0	
39	0h1527	V2 Percy1	output% at V2 minimum voltage	0-100[%]	0.00	0		0	0	0	0	0	
40	0h1528	V2 Voltx2	V2 input maximum voltage	0-10[V]	10.00	0		X	X	0	0	0	
41	0h1529	V2 Percy2	output% at V2 maximum voltage	0-100[%]	100.00	0		0	0	0	0	0	
42	0h152A	V2-Voltx1'	V2-input minimum voltage	-10-0[V]	0.00	0		0	0	0	0	0	
43	0h152B	V2-Percy1'	output% at V2-minimum voltage	-100-0[%]	0.00	0		0	0	0	0	0	
44	0h152C	V2-VoltxZ	V2-input maximum voltage	-10-0[V]	-10.00	0		0	0	0	0	0	
45	0h152F	V2-PercyZ	output% at V2-maximum voltage	-100-0[%]	-100.00	0		0	0	0	0	0	
46	0h1530	V2 Inverting	rotation direction change	0 No 1 Yes	0: No	0		0	0	0	0	0	
47	0h1532	V2 Quantizing	V2 quantization level	0.04-10[%]	0.04	0		0	0	0	0	0	
50	0h1534	I2 Monitor[mA]	I2 input amount display	0-20[mA]	0.00	0		7-8	0	0	0	0	0
52	0h1535	I2 Filter	I2 input filter time constant	0-10000 [msec]	15	0			0	0	0	0	0
53	0h1536	I2 Currx1	I2 input minimum current	0-20[mA]	4.00	0			0	0	0	0	0
54	0h1537	I2 Percy1	output% at I2 minimum current	0-100[%]	0.00	0			0	0	0	0	0
55	0h1538	I2 Currx2	I2 input maximum current	4-20[mA]	20.00	0			0	0	0	0	0
56	0h153D	I2 Percy2	output% at I2 maximum current	0-100[%]	100.00	0	0		0	0	0	0	
61	0h153E	I2 Inverting	rotation direction change	0 No 1 Yes	0: No	0	0		0	0	0	0	
62	0h153F	I2 Quantizing	I2 quantization level	0.04-10[%]	0.04	0	0		0	0	0	0	

The grey code refers to hidden code, emerging only in case of setting of the code.

Note 2) IN-35-62 codes are displayed only when the extended IO board is mounted.

Input Terminal Block Function Group (PAR → IN)

No.	Communication No.	Function Display	Name	Setting Range	Initial Value	Shift in Operation	Page	Control Mode				
								V / F	S L	V C	S L T	V C T
65	Qh1541	P1 Define	P1 terminal function setting	0 NONE	1:FX	X	7-12	0	0	0	0	0
				1 FX								
66	Qh1542	P2 Define	P2 terminal function setting	2 RX	2:RX	X		X	X	0	0	0
67	Qh1543	P3 Define	P3 terminal function setting	3 RST	5:BX	X	10-13	0	0	0	0	0
68	Qh1544	P4 Define	P4 terminal function setting	4 External Trip	4:Excl	X	10-7	0	0	0	0	0
69	Qh1545	P5 Define	P5 terminal function setting	5 BX	7:Sp-L	X	10-13	0	0	0	0	0
70	Qh1546	P6 Define	P6 terminal function setting	6 JOG	8:Sp-M	X	8-4	0	0	0	0	0
71	Qh1547	P7 Define	P7 terminal function setting	7 Speed-L	9:Sp-H	X	7-9	0	0	0	0	0
72	Qh1548	P8 Define	P8 terminal function setting	8 Speed-M	6:JOG	X		0	0	0	0	0
73 Note 2)	Qh1549	P9 Define	P9 terminal function setting	9 Speed-H	0: NONE	X	7-9	0	0	0	0	0
74	Qh154A	P10 Define	P10 terminal function setting	10 Speed-X		X						
75	Qh154B	P11 Define	P11 terminal function setting	11 XCEL-L		X	7-17	0	0	0	0	0
				12 XCEL-M			7-17					
				13 RUN Enable			8-8					
				14 3-Wire			8-7					
				15 2nd Source			7-28					
				16 Exchange			8-41					
				17 Up			8-6					
				18 Down								
				19 -reserved-			-					
				20 UID Clear			8-6					
				21 Analog Hold			7-8					
				22 I-Term Clear								
				23 PID Openloop			8-12					
				24 P Gain2								
				25 XCEL Stop			7-19					
				26 2nd Motor			8-41					
				27 Trv Offset Lo			8-51					
				28 Trv Offset Hi								
				29 Interlock 1			8-59					
				30 Interlock 2								
				31 Interlock 3								
				32 Interlock 4								

* The grey code refers to hidden code, emerging only in case of setting of the code.

Note 2) IN73~75 codes are displayed only when the extended IO board is mounted.

Chapter 8 Table of Functions

Input Terminal Block Function Group (PAR → IN)

No.	Communication No.	Function Display	Name	Setting Range	Initial Value	Shift in Operation	Page	Control Mode						
								V / F	S L	V C	S L T	V C T		
-	-	-	-	33	Reserved-	-	-	-	-	-	-	-	-	-
				34	Pre Excite			-						
				35	Speed/Torque			8-31						
				36	ASR Gain 2			8-27						
				37	ASR P/PI									
				38	Timer In			9-12						
				39	Thermal In			10-5						
				40	Dis Aux Ref			8-1						
				41	SEQ-1			8-49						
				42	SEQ-2									
				43	Manual									
				44	Go Step									
				45	Hold Step									
				46	FWD JOG									
47	REV JOG	8-5												
48	Trq Bias	8-30												
85	0h1555	DI On Delay	multi-function input terminal ON filter	0-10000[msec]	10	0	7-29	0	0	0	0	0		
86	0h1556	DI Off Delay	multi-function input terminal OFF filter		3	0		0	0	0	0	0		
87	0h1557	DINCNO Sel	multi-function input contact point selection	P8-P1	0000 0000	X	7-29	0	0	0	0	0		
				0 A contact point (NO)										
			1 B contact point (NC)											
88	0h1558	RunOn Delay	operating command delay time	0-100[sec]	0.00	X	7-11	0	0	0	0	0		
89	0h1559	InCheck Time	sequential command delay time	1-5000[msec]	1	X	7-10	0	0	0	0	0		
90	0h155A	DI Status	multi-function input terminal status	P8-P1	0000 0000	0	7-29	0	0	0	0	0		
				0 On										
				1 OFF										

8.1.6 Parameter mode – Output terminal block function group (→ OUT)

Input Terminal Block Function Group (PAR → OUT)

No.	Communication No.	Function Display	Name	Setting Range	Initial Value	Shift in Operation	Page	Control Mode					
								V / F	S L	V C	S L T	V C T	
00	-	JumpCode	jump code	0-99	30	0	-	0	0	0	0	0	0
01	0h1601	AO1 Mode	analog output 1 item	0	Frequency	0: Frequency	0	95	0	0	0	0	0
				1	Current								
				2	Voltage								
				3	DC Link Volt								
				4	Torque								
				5	Watt								
				6	Idss								
				7	Iqss								
				8	Target Freq								
				9	Ramp Freq								
				10	Speed Fdb								
				11	Speed Dev								
				12	PIDRef Value								
				13	PIDFdb Value								
				14	PID Output								
				15	Constant								
02	0h1602	AO1 Gain	analog output 1 gain	-1000~1000[%]	100.0	0		0	0	0	0	0	
03	0h1603	AO1 Bias	analog output 1 bias	-100~100[%]	0.0	0		0	0	0	0	0	
04	0h1604	AO1 Filter	analog output 1 filter	0~10000[msec]	5	0		0	0	0	0	0	
05	0h1605	AO1 Const %	analog constant output 1	0~100[%]	0.0	0		0	0	0	0	0	
06	0h1606	AO1 Monitor	analog output 1 monitor	0~100[%]	0.0	-		0	0	0	0	0	
07	0h1607	AO2 Mode	analog output 2 item	0	Frequency	0: Frequency	0	97	0	0	0	0	0
				1	Current								
				2	Voltage								
				3	DC Link Volt								
				4	Torque								
				5	Watt								
				6	Idss								
				7	Iqss								
				8	Target Freq								
				9	Ramp Freq								
				10	Speed Fdb								
				11	Speed Dev								
				12	PIDRef Value								
				13	PIDFdb Value								
				14	PID Output								
				15	Constant								

Chapter 8 Table of Functions

Input Terminal Block Function Group (PAR → OUT)

No.	Communication No.	Function Display	Name	Setting Range	Initial Value	Shift in Operation	Page	Control Mode					
								V/F	S/L	V/C	S/L/T	V/C/T	
08	0h1608	AC2 Gain	analog output 2 gain	-1000~1000[%]	100.0	0	9-7	0	0	0	0	0	
09	0h1609	AC2 Bias	analog output 2 bias	-100~100[%]	0.0	0		0	0	0	0	0	
10	0h160A	AC2 Filter	analog output 2 filter	0~10000[msec]	5	0		0	0	0	0	0	
11	0h160B	AC2 Const %	analog constant output 2	0~100[%]	0.0	0		0	0	0	0	0	
12	0h160C	AC2 Monitor	analog output 2 monitor	0~1000[%]	0.0	0		0	0	0	0	0	
14 No.23	0h160E	AC3 Mode	analog output 3 item	0	Frequency	0: Frequency	0	9-7	0	0	0	0	0
				1	Current								
				2	Voltage								
				3	DC Link Volt								
				4	Torque								
				5	Wait								
				6	Idss								
				7	Iqss								
				8	Target Freq								
				9	Ramp Freq								
				10	Speed Fdb								
				11	Speed Dev								
				12	PID Ref Value								
				13	PID Fdb Value								
				14	PID Output								
15	Constant												
15	0h160F	AC3 Gain	analog output 3 gain	-1000~1000[%]	100.0	0		0	0	0	0	0	
16	0h1610	AC3 Bias	analog output 3 bias	-100~100[%]	0.0	0		0	0	0	0	0	
17	0h1611	AC3 Filter	analog output 3 filter	0~10000[msec]	5	0		0	0	0	0	0	
18	-	AC3 Const %	analog constant output 3	0~100[%]	0.0	0		0	0	0	0	0	
19	0h1613	AC3 Monitor	analog output 3 monitor	-1000~1000[%]	0.0	0		0	0	0	0	0	
20	0h1614	AC4 Mode	analog output 4 item	0	Frequency	0: Frequency	-	9-8	0	0	0	0	0
				1	Current								
				2	Voltage								
				3	DC Link Volt								
				4	Torque								
				5	Wait								
				6	Idss								
				7	Iqss								
				8	Target Freq								
				9	Ramp Freq								
				10	Speed Fdb								
				11	Speed Dev								
				12	PID Ref Value								
				13	PID Fdb Value								
				14	PID Output								
15	Constant												

Input Terminal Block Function Group (PAR → OUT)

No.	Comm. Mission No.	Function Display	Name	Setting Range	Initial Value	Shut In Operation	Page	Control Mode				
								V / F	S L	V C	S L T	V C T
21	Oh1615	AO4 Gain	analog output 2 gain	-1000~1000(%)	100.0	-	9-8	0	0	0	0	0
22	Oh1616	AO4 Bias	analog output 2 bias	-100~100(%)	0.0	0		0	0	0	0	0
23	Oh1617	AO4 Filter	analog output 2 filter	0~1000(msec)	5	0		0	0	0	0	0
24	-	AO4 Const %	analog constant output 4	0~100(%)	0.0	0		0	0	0	0	0
25	Oh1619	AO4 Monitor	analog output 2 monitor	0~1000(%)	0.0	0		0	0	0	0	0
30	Oh161E	Trip Out Mode	failure output item	Bit 000 ~ 111	010	0	9-10 9-16	0	0	0	0	0
				1 low voltage								
				2 Failure other than low voltage								
				3 Final failure of automatic re-start								
31	Oh161F	Relay 1	multi-function relay 1 item	0 NONE	28: Trip	0	9-10	0	0	0	0	0
32	Oh1620	Relay 2	multi-function relay 2 item	1 FDT-1	13: Run	0		0	0	0	0	0
33	Oh1621	Q1 Deline	multi-function output 1 item	2 FDT-2	1: FDT-1	0		0	0	0	0	0
34 Notes	Oh1622	Relay 3	multi-function output 2 item	3 FDT-3	2: FDT-2	0		0	0	0	0	0
35	Oh1623	Relay 4	multi-function output 3 item	4 FDT-4	3: FDT-3	0		0	0	0	0	0
36	Oh1624	Relay 5	multi-function output 4 item	5 Over Load	4: FDT-4	0	0	0	0	0	0	
-	-	-	-	6 IOL	-	-	-	-	-	-	-	
				7 Under Load								
				8 Fan Warning								
				9 Stall								
				10 Over Voltage								
				11 Low Voltage								
				12 Over Heat								
				13 Lost Command								
				14 Run								
				15 Stop								
				16 Steady								
				17 Inverter Line								
				18 Comm Line								
				19 Speed Search								
				20 Stop Pulse								
				21 Seq Pulse								
				22 Ready								
				23 Trv Acc								
				24 Trv Dec								
				25 MMC								
				26 Zspd Dec								
				27 Torque Dec								
				28 Timer Out								

Note 25) OUT 14~25 codes are displayed only when the extended IO board is mounted.

Note 26) OUT 34~36 codes are displayed only when the extended IO board is mounted.

Chapter 8 Table of Functions

Input Terminal Block Function Group (PAR → OUT)

No.	Communication No.	Function Display	Name	Setting Range	Initial Value	ShIn Operatn	Page	Control Mode						
								V / F	S L	V C	S L T	V C T		
-	-	-	-	29 Trip	-	-	-	-	-	-	-	-	-	-
				30 Lost Keypad										
				31 DB Warn%ED										
				32 ENC Tune										
				33 ENC Dir										
				34 On/Off Control										
35 BR Control														
41	0h1629	DO Status	multi-function output monitoring	-	000	X	9-8	-	-	-	-	-	-	-
50	0h1632	DO On Delay	multi-function output ON delay	0~100[sec]	0.00	0	9-13	0	0	0	0	0	0	0
51	0h1633	DO Off Delay	multi-function output OFF delay	0~100[sec]	0.00	0		0	0	0	0	0	0	0
52	0h1634	DO NC/NO Sel	multi-function output contact point selection	Q1_Relay2,Relay1	000	X	9-13	0	0	0	0	0	0	0
				0 A contact point (NO)										
				1 B contact point (NC)										
53	0h1635	TripOut OnDly	failure output ON delay	0~100[sec]	0.00	0	9-14	0	0	0	0	0	0	0
54	0h1636	TripOut OffDly	failure output OFF delay	0~100[sec]	0.00	0		0	0	0	0	0	0	0
55	0h1637	TimerOn Delay	timer ON delay	0~100.00[sec]	0.00	0	9-12	0	0	0	0	0	0	0
56	0h1638	TimerOff Delay	timer OFF delay	0~100.00[sec]	100.0	0		0	0	0	0	0	0	0
57	0h1639	FDT Frequency	detection frequency	0~maximum frequency[Hz]	30.00	0	9-10	0	0	0	0	0	0	0
58	0h163A	FDT Band	detection frequency width	0~maximum frequency[Hz]	10.00	0		0	0	0	0	0	0	0
59	0h163B	TD Level	detection torque amount	0~150[%]	100	0	9-12	X	X	0	X	0	0	
60	0h163C	TD Band	detection torque width	0~10[%]	5.0	0		X	X	0	X	0	0	

* The grey code refers to hidden code, emerging only in case of setting of the code.

8.1.7 Parameter mode – Communication function group (→COM)

Communication Function Group (PAR → COM)

No.	Communication No.	Function Display	Name	Setting Range	Initial Value	Shift in Operation	Page	Control Mode					
								V/F	S/L	V/C	S/L/T	V/C/T	
00	-	Jump Code	jump code	0-99	20	0	-	0	0	0	0	0	0
01	0h1701	Int485 St ID	built-in communication inverter ID	0-250	1	0	11-3	0	0	0	0	0	0
02	0h1702	Int485 Protb	built-in communication protocol	0 ModBus RTU 1 -Reserved- 2 Serial Debug	0: ModBus RTU	0		0	0	0	0	0	0
03	0h1703	Int485 BaudR	built-in communication speed	0 1200 bps	3: 9600 bps	0	11-3	0	0	0	0	0	0
				1 2400 bps									
				2 4800 bps									
				3 9600 bps									
				4 19200 bps									
				5 38400 bps									
04	0h1704	Int485 Mode	built-in communication frame setting	0 D8PNS1	0: D8PNS1 1	-	-	0	0	0	0	0	
				1 D8PNS2									
				2 D8PES1									
				3 D8POS1									
06	0h1706	Resp Delay	Transmission delay after reception	0-1000[ms]	5ms	0	0	0	0	0	0	0	
06 Head7)	0h1706	FBUS SHW Ver	communication option SHW version	-	0.00	0	0	0	0	0	0	0	
07	0h1707	FBUS ID	communication option inverter ID	0-255	1	0	Option	0	0	0	0	0	0
08	0h1708	FBUS BaudRate	FBUS communication speed	-	12Mbps	-		0	0	0	0	0	0
09	0h1709	FieldBus LED	communication option LED status	-	-	0		0	0	0	0	0	0
30	0h171E	ParaStatus Num	-	0-6	3	0	11-7	0	0	0	0	0	0
31	0h171F	Para Staute-1	output address 1	0000-FFFF Hex	000A	0		0	0	0	0	0	0
32	0h1720	Para Staute-2	output address 2		000E	0		0	0	0	0	0	0
33	0h1721	Para Staute-3	output address 3		000F	0		0	0	0	0	0	0
34	0h1722	Para Staute-4	output address 4		0000	0		0	0	0	0	0	0
35	0h1723	Para Staute-5	output address 5		0000	0		0	0	0	0	0	0
36	0h1724	Para Staute-6	output address 6		0000	0		0	0	0	0	0	0
37	0h1725	Para Staute-7	output address 7		0000	0		0	0	0	0	0	0
38	0h1726	Para Staute-8	output address 8		0000	0		0	0	0	0	0	0

Note 27) The grey code refers to hidden code, emerging only in case of setting of the code. COM 06~17 codes are displayed only when the communication option card is mounted. Refer to Option manual for Option.

Chapter 8 Table of Functions

Communication Function Group (PAR → COM)

No.	Communication No.	Function Display	Name	Setting Range	Initial Value	Still in Operation	Page	Control Mode						
								V/F	S/L	V/C	S/L/T	V/C/T		
50	0h1732	Para Ctl Num	-	0-8	2	0		0	0	0	0	0	0	
51	0h1733	Para Control-1	input address 1	0000-FFFF Hex	0005	X	11-7	0	0	0	0	0	0	
52	0h1734	Para Control-2	input address 2		0006	X		0	0	0	0	0	0	0
53	0h1735	Para Control-3	input address 3		0000	X		0	0	0	0	0	0	0
54	0h1736	Para Control-4	input address 4		0000	X		0	0	0	0	0	0	0
55	0h1737	Para Control-5	input address 5		0000	X		0	0	0	0	0	0	0
56	0h1738	Para Control-6	input address 6		0000	X		0	0	0	0	0	0	0
57	0h1739	Para Control-7	input address 7		0000	X		0	0	0	0	0	0	0
58	0h173A	Para Control-8	input address 8		0000	X		0	0	0	0	0	0	0
70	0h1746	Virtual DI 1	communication multi-function input 1	0 None	0: None	0	11-4	0	0	0	0	0	0	
71	0h1747	Virtual DI 2	communication multi-function input 2	1 FX		0		0	0	0	0	0	0	0
72	0h1748	Virtual DI 3	communication multi-function input 3	2 RX		0		0	0	0	0	0	0	0
73	0h1749	Virtual DI 4	communication multi-function input 4	3 RST		0		0	0	0	0	0	0	0
74	0h174A	Virtual DI 5	communication multi-function input 5	4 External Trip		0		0	0	0	0	0	0	0
75	0h174B	Virtual DI 6	communication multi-function input 6	5 BK		0		0	0	0	0	0	0	0
76	0h174C	Virtual DI 7	communication multi-function input 7	6 JOG		0		0	0	0	0	0	0	0
77	0h174D	Virtual DI 8	communication multi-function input 8	7 Speed-L		0		0	0	0	0	0	0	0
78	0h174E	Virtual DI 9	communication multi-function input 9	8 Speed-M		0		0	0	0	0	0	0	0
79	0h174F	Virtual DI 10	communication multi-function input 10	9 Speed-H		0		0	0	0	0	0	0	0
80	0h1750	Virtual DI 11	communication multi-function input 11	10 Speed-X		0		0	0	0	0	0	0	0
81	0h1751	Virtual DI 12	communication multi-function input 12	11 XCEL-L		0		0	0	0	0	0	0	0
82	0h1752	Virtual DI 13	communication multi-function input 13	12 XCEL-M		0		0	0	0	0	0	0	0
83	0h1753	Virtual DI 14	communication multi-function input 14	13 RUN Enable		0		0	0	0	0	0	0	0
84	0h1754	Virtual DI 15	communication multi-function input 15	14 3-Wire		0		0	0	0	0	0	0	0
85	0h1755	Virtual DI 16	communication multi-function input 16	15 2nd Source		0		0	0	0	0	0	0	0
				16 Exchange										
				17/18 Up/Down										
				19 Reserved										
				20 UID Clear										
				21 Analog Hold										
				22 I-Term Clear										
				23 PID Openloop										
				24 P Gain2	0: None	0	-	0	0	0	0	0	0	
				25 XCEL Stop										
				26 2nd Motor										
				27 Trv Offset Lo										
				28 Trv Offset Hi										
				29 Interlock 1										
				30 Interlock 2										
				31 Interlock 3										
				32 Interlock 4										

No.	Communication No.	Function Display	Name	Setting Range	Initial Value	Still in Operation	Page	Control Mode									
								V/F	S/L	V/C	S/L/T	V/C/T					
				33 Reserved													
				34 Pre Excite													
				35 Speed/Torque													
				36 ASR Gain 2													
				37 ASR P/PI													
				38 Timer In													
				39 Thermal In													
				40 Dis Aux Ref													
				41 SEQ-1													
				42 SEQ-2													
				43 Manual													
				44 Go Step													
				45 Hold Step													
				46 FWD JOG													
				47 REV JOG													
				48 Trq Bias													
86	0h1756	Vrt DI Status	Comm. Multi-function input monitoring	-	-	0	X					0	0	0	0	0	
90	0h175A	Comm Mon Sel	monitor type selection	0	Int485	0	0	11-5					0	0	0	0	0
				1	Keypad												
				2	Field Bus												
91	0h175B	Rcv Frame Num	Number of reception frames	-	-	0	-					0	0	0	0	0	0
92	0h175C	Err Frame Num	Number of error frames	-	-	0	-					0	0	0	0	0	0
93	0h175D	Nak Frame Num	Number of writing error frames	-	-	0	-					0	0	0	0	0	0
94 <small>(note 27)</small>	-	Comm Update	-	0	No	0	-					0	0	0	0	0	0
				1	Yes												

(note 27-2) COM 94 is displayed when communication option board is inserted.

8.1.8 Parameter mode – Applied function group (→APP)

Applied Function Group (PAR → APP)

No.	Communication No.	Function Display	Name	Setting Range	Initial Value	Still in Operation	Page	Control Mode					
								V / F	S / L	V / C	S / L / T	V / C / T	
00	-	Jump Code	Jump code	0-99	20	0	-	0	0	0	0	0	0
01	0h1801	App Mode	applied function selection	0 None	0: None	X	-	0	0	0	X	X	
				1 Traverse									
				2 Proc PID									
				3 Reserved									
				4 Auto Sequence									
08 <small>Note 28)</small>	0h1806	Trv Aprmt %	traverse operating range	0-20[%]	0.0	0	8-51	0	0	0	X	X	
09	0h1809	Trv Scramb %	traverse scramble magnitude	0-50[%]	0.0	0		0	0	0	X	X	
10	0h180A	Trv Acc Time	traverse accelerating time	0.1-600.0[sec]	2.0	0		0	0	0	X	X	
11	0h180B	Trv Dec Time	traverse decelerating time	0.1-600.0[sec]	3.0	0		0	0	0	X	X	
12	0h180C	Trv Offset Hi	traverse offset upper limit	0-20.0[%]	0.0	0		0	0	0	X	X	
13	0h180D	Trv Offset Lo	traverse offset lower limit	0-20.0[%]	0.0	0		0	0	0	X	X	
16 <small>Note 29)</small>	0h1810	PID Output	PID output monitor	[%]	0.00	-		0	0	0	X	X	
17	0h1811	PID Ref Value	PID reference monitor		50.00	-	0	0	0	X	X		
18	0h1812	PID Fdb Value	PID feedback monitor		0.00	-	0	0	0	X	X		
19	0h1813	PID Ref Set	PID reference setting		-100-100[%]	50%	0	0	0	X	X		
20	0h1814	PID Ref Source	PID reference selection	0 Keypad	0: Keypad	X	8-12	0	0	0	X	X	
				1 V1									
				2 I1									
				3 V2									
				4 I2									
				5 Int 485									
				6 Encoder									
				7 FieldBus									
				8 PLC									
				9 Synchro									
				10 Binary Type									

* The grey code refers to hidden code, emerging only in case of setting of the code.

Note 28) APP 08~13 codes are displayed only when APP-01 (App Mode) is set as "Traverse".

Note 29) APP 16~45 codes are displayed only when APP-01 (App Mode) is set as "Proc PID" or APP-01(App Mode) is set as "MMC" and Reql Bypass(APO-34) is set as "No".

Applied Function Group (PAR → APP)

No.	Communication No.	Function Display	Name	Setting Range	Initial Value	Shut in Operation	Page	Control Mode					
								V/F	S/L	V/C	S/L/T	V/C/T	
21	0h1815	PID F/B Source	PID Feedback selection	0	V1	0:V1	X	8-12	0	0	0	X	X
				1	I1								
				2	V2								
				3	I2								
				4	Int.485								
				5	Encoder								
				6	FieldBus								
				7	PLC								
				8	Synchro								
9	Binary Type												
22	0h1816	PID P-Gain	PID proportional gain	0-1000[%]	50.0	0		0	0	0	X	X	
23	0h1817	PID I-Time	PID integral calculus time	0-200.0[sec]	10.0	0		0	0	0	X	X	
24	0h1818	PID D-Time	PID differential time	0-1000[msec]	0	0		0	0	0	X	X	
25	0h1819	PID F-Gain	PID Feed forward gain	0-1000.0[%]	0.0	0		0	0	0	X	X	
26	0h181A	P Gain Scale	Proportional gain scale	0-100.0[%]	100.0	X		0	0	0	X	X	
27	0h181B	PID Out LPF	PID output filter	0-1000[ms]	0	0		0	0	0	X	X	
29	0h181D	PID Limit Hi	PID upper limit frequency	PID lower limit frequency[Hz] -300[Hz]	60.00	0		0	0	0	X	X	
30	0h181E	PID Limit Lo	PID lower limit frequency	-300 ~ PID upper limit frequency[Hz]	-60	0		0	0	0	X	X	
31	0h181F	PID Out Inv	PID output reversal	0	No	0:No	X	8-12	0	0	0	X	X
				1	Yes								
32	0h1820	PID Out Scale	PID output scale	0.1-1000[%]	100.0	X		0	0	0	X	X	
34	0h1822	Pre-PID Freq	PID control period movement frequency	0-maximum frequency[Hz]	0.00	X		0	0	0	X	X	
35	0h1823	Pre-PID Exit	PID control period movement level	0-100[%]	0.0	X		0	0	0	X	X	
36	0h1824	Pre-PID Delay	PID control period movement delay time	0-9999[sec]	600	0		0	0	0	X	X	
37	0h1825	PID Sleep DT	PID sleep mode delay time		60.0	0		0	0	0	X	X	
38	0h1826	PID Sleep Freq	PID Sleep mode frequency	0-maximum frequency[Hz]	0.00	0		0	0	0	X	X	
39	0h1827	PID WakeUp Lav	PID Wake up level	0-100[%]	35	0		0	0	0	X	X	
40	0h1828	PID WakeUp Mod	PID Wake up mode setting	0	Below Level	0:Below Level	0	8-12	0	0	0	X	X
				1	Above Level								
				2	Beyond Level								
42	0h182A	PID Unit Sel	PID control period unit selection	0	%	0:%	0	8-12	0	0	0	X	X
				1	Bar								
				2	mBar								
				3	Pa								

Chapter 8 Table of Functions

No.	Communication No.	Function Display	Name	Setting Range	Initial Value	Shift in Operation	Page	Control Mode					
								V / F	S L	V C	S L T	V C T	
				4 KPa									
				5 Hz									
				6 rpm									
				7 V									
				8 I									
				9 kW									
				10 HP									
				11 °C									
				12 °F									
43	0h182B	PID Unit Gain	PID unit gain	0-300%	100.00	0		0	0	0	X	X	
44	0h182C	PID Unit Scale	PID unit scale	0 X100	2x1	0	8-12	0	0	0	X	X	
				1 X10									
				2 X1									
				3 X0.1									
				4 X0.01									
45	0h182D	PID P2-Gain	PID 2 nd proportional gain	0-1000%	100.0	X		0	0	0	X	X	

8.1.9 Parameter mode – Auto sequence operation group (→AUT)

Auto sequence operation Group (PAR → AUT)

No.	Communication No.	Function Display	Name	Setting Range	Initial Value	Shift Operation	Page	Control Mode				
								V/F	S/L	V/C	S/L/T	V/C/T
00	-	Jump Code	jump code	0-99	10	0	-	0	0	0	X	X
01	0h1901	Auto Mode	auto operation type	0 Auto-A 1 Auto-B	0:Auto-A	X	8-50	0	0	0	X	X
02 <small>(Next)</small>	0h1902	Auto Check	Auto operation terminal delay time	0.02-2.00[sec]	0.10	X		0	0	0	X	X
03	0h1903	Seq Select	sequence type selection	1-2	1	0		0	0	0	X	X
04 <small>(Next)</small>	0h1904	Step Number 1	Number of sequence 1 steps	1-8	2	0		0	0	0	X	X
05 <small>(Next)</small>	0h1905	Step Number 2	Number of sequence 2 steps			0		0	0	0	X	X
10 <small>(Next)</small>	0h190A	Seq 1/1 Freq	1/1 step frequency	0.01 -maximum frequency[Hz]	11.00	0		0	0	0	X	X
11	0h190B	Seq 1/1 XaccT	1/1 Acc/Dec time	0.1-600.0[sec]	5.0	0		0	0	0	X	X
12	0h190C	Seq 1/1 SteadT	1/1 steady speed operation time			0		0	0	0	X	X
13	0h190D	Seq 1/1 Dir	1/1 operation direction	0 Reverse 1 Forward	1:Forward	0		0	0	0	X	X
14	0h190E	Seq 1/2 Freq	1/2 step frequency	0.01-maximum frequency[Hz]	21.00	0		0	0	0	X	X
15	0h190F	Seq 1/2 XaccT	1/2 Acc/Dec time	0.1-600.0[sec]	5.0	0	0	0	0	X	X	
16	0h1910	Seq 1/2 SteadT	1/2 steady speed operation time			0	0	0	0	X	X	
17	0h1911	Seq 1/2 Dir	1/2 operation direction	0 Reverse 1 Forward	1:Forward	0	0	0	0	X	X	
18	0h1912	Seq 1/3 Freq	1/3 step frequency	0.01-maximum frequency[Hz]	31.00	0	0	0	0	X	X	
19	0h1913	Seq 1/3 XaccT	1/3 Acc/Dec time	0.1-600.0[sec]	5.0	0	0	0	0	X	X	
20	0h1914	Seq 1/3 SteadT	1/3 steady speed operation time			0	0	0	0	X	X	
21	0h1915	Seq 1/3 Dir	1/3 operation direction	0 Reverse 1 Forward	1:Forward	0	0	0	0	X	X	
22	0h1916	Seq 1/4 Freq	1/4 step frequency	0.01-maximum frequency[Hz]	41.00	0	0	0	0	X	X	
23	0h1917	Seq 1/4 XaccT	1/4 Acc/Dec time	0.1-600.0[sec]	5.0	0	0	0	0	X	X	

Chapter 8 Table of Functions

No.	Communication No.	Function Display	Name	Setting Range	Initial Value	Shift in Operation	Page	Control Mode					
								V / F	S L	V C	S L T	V C T	
24	0h1918	Seq 1/4 SteadT	1/4 steady speed operation time	0.1-600.0[sec]	5.0	0	8-51	0	0	0	X	X	
25	0h1919	Seq 1/4 Dir	1/4 operation direction	0 Reverse 1 Forward	1: Forward	0		0	0	0	0	X	X
26	0h191A	Seq 1/5 Freq	1/5 step frequency	0.01-maximum frequency[Hz]	51.00	0		0	0	0	0	X	X
27	0h191B	Seq 1/5 XcelT	1/5 Acc/Dec time	0.1-600.0[sec]	5.0	0		0	0	0	0	X	X
28	0h191C	Seq 1/5 SteadT	1/5 steady speed operation time			0		0	0	0	0	0	X
29	0h191D	Seq 1/5 Dir	1/5 operation direction	0 Forward 1 Auto-B	0: Forward	0		0	0	0	0	X	X
30	0h191E	Seq 1/6 Freq	1/6 step frequency	0.01-maximum frequency[Hz]	60.00	0		0	0	0	0	X	X
31	0h191F	Seq 1/6 XcelT	1/6 Acc/Dec time	0.1-600.0[sec]	5.0	0		0	0	0	0	X	X
32	0h1920	Seq 1/6 SteadT	1/6 steady speed operation time			0		0	0	0	0	0	0
33	0h1921	Seq 1/6 Dir	1/6 operation direction	0 Forward 1 Auto-B	0: Forward	8-59		0	0	0	0	X	X
34	0h1922	Seq 1/7 Freq	1/7 step frequency	0.01-maximum frequency[Hz]	51.00	0		0	0	0	0	X	X
35	0h1923	Seq 1/7 XcelT	1/7 Acc/Dec time	0.1-600.0[sec]	5.0	0		0	0	0	0	X	X
36	0h1924	Seq 1/7 SteadT	1/7 steady speed operation time			0		0	0	0	0	0	0
37	0h1925	Seq 1/7 Dir	1/7 operation direction	0 Reverse 1 Forward	1: Forward	0		0	0	0	0	X	X
38	0h1926	Seq 1/8 Freq	1/8 step frequency	0.01-maximum frequency[Hz]	21.00	0		0	0	0	0	X	X
39	0h1927	Seq 1/8 XcelT	1/8 Acc/Dec time	0.1-600.0[sec]	5.0	0		0	0	0	0	X	X
40	0h1928	Seq 1/8 SteadT	1/8 steady speed operation time			0		0	0	0	0	0	0
41	0h1929	Seq 1/8 Dir	1/8 operation direction	0 Reverse 1 Forward	1: Forward	0		0	0	0	0	X	X
43 <small>(read)</small>	0h192B	Seq 2/1 Freq	2/1 step frequency	0.01-maximum frequency[Hz]	12.00	0		0	0	0	0	X	X
44	0h192C	Seq 2/1 XcelT	2/1 Acc/Dec time	0.1-600.0[sec]	5.0	0		0	0	0	0	X	X
45	0h192D	Seq 2/1 SteadT	2/1 steady speed operation time			0		0	0	0	0	0	0

No.	Communication No.	Function Display	Name	Setting Range	Initial Value	Shift in Operation	Page	Control Mode				
								V / F	S / L	V / C	S / L / T	V / C / T
46	0h192E	Seq 21 Dir	2/1 operation direction	0	Reverse	1:	0	0	0	0	X	X
				1	Forward	Forward						
47	0h192F	Seq 22 Freq	2/2 step frequency	0.01-maximum frequency[Hz]	22.00	0	8-51	0	0	0	X	X
48	0h1930	Seq 22 XcelT	2/2 AccDec time	0.1-600.0[sec]	5.0	0		0	0	0	X	X
49	0h1931	Seq 22 SteadT	2/2 steady speed operation time			0	0	0	0	X	X	
50	0h1932	Seq 22 Dir	2/2 operation direction	0	Reverse	1:	0	0	0	0	X	X
				1	Forward	Forward						
51	0h1933	Seq 23 Freq	2/3 step frequency	0.01-maximum frequency[Hz]	32.00	0	8-51	0	0	0	X	X
52	0h1934	Seq 23 XcelT	2/3 AccDec time	0.1-600.0[sec]	5.0	0		0	0	0	X	X
53	0h1935	Seq 23 SteadT	2/3 steady speed operation time			0	0	0	0	X	X	
54	0h1936	Seq 23 Dir	2/3 operation direction	0	Forward	0:	0	0	0	0	X	X
				1	Auto-B	Forward						
52	0h1937	Seq 24 Freq	2/4 step frequency	0.01-maximum frequency[Hz]	42.00	0	8-51	0	0	0	X	X
56	0h1938	Seq 24 XcelT	2/4 AccDec time	0.1-600.0[sec]	5.0	0		0	0	0	X	X
57	0h1939	Seq 24 SteadT	2/4 steady speed operation time			0	0	0	0	X	X	
58	0h193A	Seq 24 Dir	2/4 operation direction	0	Forward	0:	0	0	0	0	X	X
				1	Auto-B	Forward						
59	0h193B	Seq 25 Freq	2/5 step frequency	0.01-maximum frequency[Hz]	52.00	0	8-51	0	0	0	X	X
60	0h193C	Seq 25 XcelT	2/5 AccDec time	0.1-600.0[sec]	5.0	0		0	0	0	X	X
61	0h193D	Seq 25 SteadT	2/5 steady speed operation time			0	0	0	0	X	X	
62	0h193E	Seq 25 Dir	2/5 operation direction	0	Reverse	1:	0	0	0	0	X	X
				1	Forward	Forward						
63	0h193F	Seq 26 Freq	2/6 step frequency	0.01-maximum frequency[Hz]	60.00	0	8-51	0	0	0	X	X
64	0h1940	Seq 26 XcelT	2/6 AccDec time	0.1-600.0[sec]	5.0	0		0	0	0	X	X
65	0h1941	Seq 26 SteadT	2/6 steady speed operation time			0	0	0	0	X	X	
66	0h1942	Seq 26 Dir	2/6 operation direction	0	Reverse	1:Forward	0	0	0	0	X	X

Chapter 8 Table of Functions

No.	Communication No.	Function Display	Name	Setting Range		Initial Value	Shift in Operation	Page	Control Mode						
									V/F	S/L	V/C	S/L/T	V/C/T		
				1	Forward	d									
67	0h1943	Seq 2/7 Freq	2/7 step frequency	0.01-maximum frequency[Hz]		52.00	0	8-51	0	0	0	X	X		
68	0h1944	Seq 2/7 XcelT	2/7 Acc/Dec time	0.1-600.0[sec]		5.0	0		0	0	0	X	X		
69	0h1945	Seq 2/7 SteadT	2/7 steady speed operation time				0		0	0	0	X	X		
70	0h1946	Seq 2/7 Dir	2/8 operation direction	0	Reverse	1:	0		0	0	0	0	X	X	
				1	Forward	Forward									
71	0h1947	Seq 2/8 Freq	2/8 step frequency	0.01-maximum frequency[Hz]		22.00	0		0	0	0	X	X		
72	0h1948	Seq 2/8 XcelT	2/8 Acc/Dec time	0.1-600.0[sec]		5.0	0		0	0	0	X	X		
73	0h1949	Seq 2/8 SteadT	2/8 steady speed operation time				0		0	0	0	X	X		
74	0h194A	Seq 2/8 Dir	2/8 operation direction	0	Reverse	1:	0	0	0	0	0	X	X		
				1	Forward	Forward									

* The grey code refers to hidden code, emerging only in case of setting of the code.

Note 30) AUT group is displayed only when APP-0 1(App Mode) is set as "Auto Sequence".

Note 31) AUT-04 codes are displayed only when AUT-03 (Seq Select) is set as "1".

Note 32) AUT-05 codes are displayed only when AUT-03 (Seq Select) is set as "2".

Note 33) AUT-10~41 codes are displayed only when AUT-03 (Seq Select) is set as "1".

Note 34) AUT-43~74 codes are displayed only when AUT-03 (Seq Select) is set as "2".

8.1.10 Parameter mode – Option card function group (→APO)

Option Card Function Group (PAR → APO)

No.	Communication No.	Function Display	Name	Setting Range	Initial Value	Shut in Operation	Page	Control Mode					
								V/F	S/L	V/C	S/L/T	V/C/T	
00	-	Jump Code	jump code	0-99	20	0	-	0	0	0	0	0	
01 Hexa	0h1A01	Enc Opt Mode	encoder function item	0 None	0:None	0	8-19	0	0	0	0	0	
				1 Feed-Back									
				2 Reference									
04	0h1A04	Enc Type Sel	encoder type selection	0 Line Driver	0: Line Driver	X	8-19	0	0	0	0	0	
				2 Open Collector									
05	0h1A05	Enc Pulse Sel	encoder pulse direction	0 (A+B)	0: (A+B)	X	8-19	0	0	0	0	0	
				1 -(A+B)									
				2 A									
06	0h1A06	Enc Pulse Num	Number of encoder pulses	10-4096	1024	X	8-19	0	0	0	0	0	
08	0h1A08	Enc Monitor	Feed Back monitor	-	-	0	8-19	0	0	0	0	0	
09	0h1A09	Pulse Monitor	Reference monitor	-	-	0	8-19	0	0	0	0	0	
10	0h1A0A	Enc Filter	encoder input filter	0-10000[msec]	3	0	8-19	0	0	0	0	0	
11	0h1A0B	Enc Pulse x1	Enc input minimum pulse	0-100[Hz]	0.0	0	7-7	0	X	0	X	0	
12	0h1A0C	Enc Percy1	output[%] at Enc minimum pulse	0-100[%]	0.00	0		0	X	0	X	0	
13	0h1A0D	Enc Pulse x2	Enc input maximum pulse	0-200[Hz]	100	0		0	X	0	X	0	
14	0h1A0E	Enc Percy2	Enc maximum pulse\ output[%]	0-100[%]	100	0		0	X	0	X	0	
20 Hexa	0h1A14	Aux Motor Run	display of number of auxiliary motor movement	0-4	0	0	8-55	0	0	0	X	X	
21	0h1A15	Starting Aux	starting auxiliary motor selection	1-4	1	X	8-55	0	0	0	X	X	
22	0h1A16	Auto Op Time	auto change operation time	XX:XX[Min]	0:00	0	8-55	0	0	0	X	X	
23	0h1A17	Start Freq 1	1st auxiliary motor starting frequency	0-60[Hz]	49.99	0	8-55	0	0	0	X	X	
24	0h1A18	Start Freq 2	2nd auxiliary motor starting frequency			0		0	0	X	X		
25	0h1A19	Start Freq 3	3rd auxiliary motor starting frequency			0		0	0	X	X		
26	0h1A1A	Start Freq 4	4th auxiliary motor starting frequency			0		0	0	X	X		
27	0h1A1B	Stop Freq 1	1st auxiliary motor stop frequency			0		15.00	0	0	0	X	X
28	0h1A1C	Stop Freq 2	2nd auxiliary motor stop frequency			0			0	0	X	X	
29	0h1A1D	Stop Freq 3	3rd auxiliary motor stop frequency	0	0	0	X		X				
30	0h1A1E	Stop Freq 4	4th auxiliary motor stop frequency	0	0	0	X		X				
31	0h1A1F	Aux Start DT	auxiliary motor starting delay time	0-360.0[sec]	60.0	0	0	0	0	X	X		
32	0h1A20	Aux Stop DT	auxiliary motor stop delay time			0	0	0	0	X	X		
33	0h1A21	Num of Aux	auxiliary motor number selection	0-4	4	X	8-55	0	0	0	X	X	
34	0h1A22	Regul Bypass	bypass selection	0 No	0: No	X	8-55	0	0	0	X	X	
				1 Yes									

Chapter 8 Table of Functions

No.	Communication No.	Function Display	Name	Setting Range	Initial Value	Shift in Operation	Page	Control Mode				
								V / F	S / L	V / C	S / L	V / C
35	0h1A23	Auto Ch Mode	auto change mode selection	0 None	1:Aux	X	8-55	0	0	0	X	X
				1 Aux								
				2 Main								
36	0h1A24	Auto Ch Time	auto change time	0-99.00[min]	72.00	0	0	0	0	X	X	
38	0h1A26	Interlock	interlock selection	0 No	0:No	0	8-55	0	0	0	X	X
				1 Yes								
39	0h1A27	Interlock DT	interlock movement delay time	0.1-360.0[sec]	5.0	0	0	0	0	X	X	
40	0h1A28	Actual Pr Diff	auxiliary motor movement pressure difference	0-100[%]	2	0	0	0	0	X	X	
41	0h1A29	Aux Acc Time	main motor accelerating time when number of pumps decreases	0-600.0[sec]	2.0	0	8-55	0	0	0	X	X
42	0h1A2A	Aux Dec Time	main motor decelerating time when number of pumps increases			0						
58 (Main)	0h1A3A	PLC LED Status	PLC option LED status	-	-	0	0	0	0	0	0	
59	0h1A3B	PLC SW Ver	PLC option card SW version	-	1X	0	Option	0	0	0	0	0
60	0h1A3C	PLC Wr Data 1	-	0-FFFFF[Hex]	0000	0		0	0	0	0	0
61	0h1A3D	PLC Wr Data 2	-			0		0	0	0		
62	0h1A3E	PLC Wr Data 3	-			0		0	0	0		
63	0h1A3F	PLC Wr Data 4	-			0		0	0	0		
64	0h1A40	PLC Wr Data 5	-			0		0	0	0		
65	0h1A41	PLC Wr Data 6	-			0		0	0	0		
66	0h1A42	PLC Wr Data 7	-			0		0	0	0		
67	0h1A43	PLC Wr Data 8	-			0		0	0	0		
76	0h1A4C	PLC Rl Data 1	-			0		0	0	0		
77	0h1A4D	PLC Rl Data 2	-			0		0	0	0		
78	0h1A4E	PLC Rl Data 3	-			0		0	0	0		
79	0h1A4F	PLC Rl Data 4	-			0		0	0	0		
80	0h1A50	PLC Rl Data 5	-			0		0	0	0		
81	0h1A51	PLC Rl Data 6	-			0		0	0	0		
82	0h1A52	PLC Rl Data 7	-			0		0	0	0		
83	0h1A53	PLC Rl Data 8	-			0	0	0	0			

* The grey code refers to hidden code, emerging only in case of setting of the code.

Note 35) APO-01~14 codes are displayed only when the encoder board is mounted.

Note 36) APO-20~42 codes are displayed only when APP-01 (App Mode) is set as "MMC".

Note 37) APO-58~83 codes are displayed only when PLC option board is mounted.

8.1.11 Parameter mode – Protective function group (→ PRT)

Protective Function Group (PAR → PRT)

No.	Communication No.	Function Display	Name	Setting Range	Initial Value	Shift in Operation	Page	Control Mode				
								V / F	S L	V C	S L T	V C T
00	-	Jump Code	jump code	0-99	40	0		0	0	0	0	0
04	0h1B04	Load Duty	Load amount setting	0 Normal Duty	1: Heavy Duty	X	10-2	0	0	0	0	0
				1 Heavy Duty								
05	0h1B05	Phase Loss Chk	input/output phase open protection	Bit 00-11	00	X	10-6	0	0	0	0	0
				1 Output phase open								
				2 Input phase open								
06	0h1B06	IPO V Band	input phase open voltage band	1-100[V]	40	X		0	0	0	0	0
07	0h1B07	Trip Dec Time	decelerating time in case of failure	0-600[sec]	3.0	0	10-9	0	0	0	0	0
08	0h1B08	RST Restart	starting selection in case of failure reset	0 No	0/No	0	8-37	0	0	0	0	0
				1 Yes								
09	0h1B09	Retry Number	Number of auto restarts	0-10	0	0		0	0	0	0	0
10 heavy	0h1B0A	Retry Delay	Auto restart delay time	0-60.0[sec]	1.0	0	8-37	0	0	0	0	0
11	0h1B0B	Lost KPD Mode	movement in case of Keypad command loss	0 None	0: None	0	10-8	0	0	0	0	0
				1 Warning								
				2 Free-Run								
				3 Dec								
12	0h1B0C	Lost Cmd Mode	movement in case of speed command loss	0 None	0: None	0	10-8	0	0	0	0	0
				1 Free-Run								
				2 Dec								
				3 Hold Input								
				4 Hold Output								
5 Lost Preset												
13 heavy	0h1B0D	Lost Cmd Time	Speed command loss judgment time	0.1-120[sec]	1.0	0		0	0	0	0	0
14	0h1B0E	Lost Preset F	operation frequency in case of speed command loss	starting frequency ~ maximum frequency[Hz]	0.00	0	10-9	0	0	0	0	0
15	0h1B0F	AI Lost Level	Analog input loss judgment level	0 Half of x1	0: Half of x1	0		0	0	0	0	0
				1 Below x1								
17	0h1B11	OL Warn Select	overload alarm selection	0 No	0: No	0		0	0	0	0	0
				1 Yes								
18	0h1B12	OL Warn Level	overload alarm level	30-180[%]	150	0		0	0	0	0	0
19	0h1B13	OL Warn Time	overload alarm time	0-30.0[sec]	10.0	0	10-2	0	0	0	0	0
20	0h1B14	OL Trip Select	movement in case of overload failure	0 None	1: Free-Run	0		0	0	0	0	0
				1 Free-Run								
				2 Dec								
21	0h1B15	OL Trip Level	overload failure level	30-200[%]	180	0		0	0	0	0	0

Chapter 8 Table of Functions

No.	Communication No.	Function Display	Name	Setting Range	Initial Value	Shift in Operation	Page	Control Mode				
								V / F	S L	V C	S L T	V C T
22	0h1B16	OL Trip Time	overload failure time	0-60[sec]	60.0	0	10-2	0	0	0	0	0
25	0h1B19	UL Warn Sel	light load alarm selection	0 No	0:No	0		0	0	0	0	0
				1 Yes								
26	0h1B1A	UL Warn Time	light load alarm time	0-600.0[sec]	10.0	0		0	0	0	0	0
27	0h1B1B	UL Trip Sel	light load failure selection	0 None	0:None	0	10-11	0	0	0	0	0
				1 Free-Run								
				2 Dec								
28	0h1B1C	UL Trip Time	light load failure time	0-600[sec]	30.0	0		0	0	0	0	0
29	0h1B1D	UL LF Level	light load lower limit level	10-30[%]	30	0		0	0	0	0	0
30	0h1B1E	UL BF Level	light load upper limit level	30-100[%]	30	0		0	0	0	0	0
31	0h1B1F	No Motor Trip	movement in case of no motor detection	0 None	0:None	0		0	0	0	0	0
				1 Free-Run								
32	0h1B20	No Motor Level	no motor detection current level	1-100[%]	5	0	10-14	0	0	0	0	0
33	0h1B21	No Motor Time	no motor detection delay	0.1-10.0[sec]	3.0	0		0	0	0	0	0
34	0h1B22	Thermal-T Sel	movement selection after motor overheat detection sensor detection	0 None	0:None	0		0	0	0	0	0
				1 Free-Run								
				2 Dec								
35	0h1B23	Thermal In Sc	motor overheat detection sensor input selection	0 None	0:None	X	10-5	0	0	0	0	0
				1 V1								
				2 I1								
				3 V2								
				4 I2								
36	0h1B24	Thermal-T Lev	motor overheat detection sensor failure level	0-100[%]	50.0	0		-	-	-	-	-
37	0h1B25	Thermal-T Area	motor overheat detection sensor failure area	0 Low	0:Low	0		0	0	0	0	0
				1 High								
40	0h1B28	ETH Trip Sel	electric thermal failure selection	0 None	0:None	0		0	0	0	0	0
				1 Free-Run								
				2 Dec								
41	0h1B29	Motor Cooling	motor cooling fan type	0 Self-cool	0:Self-cool	0	10-1	0	0	0	0	0
				1 Forced-cool								
42	0h1B2A	ETH 1min	electric thermal 1 minute rating	120-200[%]	150	0		0	0	0	0	0
43	0h1B2B	ETH Cont	electric thermal consecutive rating	50-200[%]	120	0		0	0	0	0	0
50	0h1B32	Stall Prevent	stall preventing movement	Bit 0000-1111	0000	X	10-3	0	0	X	0	X
				1 Accelerating								
				2 Steady speed								
				3 Decelerating								
				4 Flux Braking								
51	0h1B33	Stall Freq 1	stall frequency 1	Start frequency 1 ~ Stall frequency 1 [Hz]	60.00	0		0	0	X	0	X

No.	Communication No.	Function Display	Name	Setting Range	Initial Value	Shift in Operation	Page	Control Mode					
								V / F	S L	V C	S L T	V C T	
52	0h1B34	Stall Level 1	stall level 1	30-250[%]	180	X	10-3	0	0	X	0	X	
53	0h1B35	Stall Freq 2	stall frequency 2	stall frequency 1 ~stall frequency 2[Hz]	60.00	0		0	0	X	0	X	
54	0h1B36	Stall Level 2	stall level 2	30-250[%]	180	X		0	0	X	0	X	
55	0h1B37	Stall Freq 3	stall frequency 3	stall frequency 2 ~stall frequency 4[Hz]	60.00	0		0	0	X	0	X	
56	0h1B38	Stall Level 3	stall level 3	30-250[%]	180	X		0	0	X	0	X	
57	0h1B39	Stall Freq 4	stall frequency 4	stall frequency 3 ~maximum frequency [Hz]	60.00	0		0	0	X	0	X	
58	0h1B3A	Stall Level 4	stall level 4	30-250[%]	180	X		0	0	X	0	X	
66	0h1B42	DB Warn %ED	DB resistance warning level	0-30[%]	0	0		10-10	0	0	0	0	0
70	0h1B46	Over SPD Freq	overspeed judgment frequency	20-130[%]	120.0	0	10-12	X	X	0	X	0	
72	0h1B48	Over SPD Time	overspeed judgment time	0.01-10.00[sec]	0.01	0		X	X	0	X	0	
73	0h1B49	Speed Dev Trip	speed error failure	0 No 1 Yes	0:No	0	10-12	X	X	0	X	X	
74	0h1B4A	Speed Dev Band	speed error width	2-maximum frequency[Hz]	20.00	0		X	X	0	X	X	
75	0h1B4B	Speed Dev Time	speed error judgment time	0.1-1000.0[sec]	1.0	0		X	X	0	X	X	
77	0h1B4D	Enc Wire Check	Encoder option connection check	0 No 1 Yes	0:No	0		X	X	0	X	0	
78	0h1B4E	Enc Check Time	Encoder connection check time	0.1-1000.0[sec]	1.0	0		X	X	0	X	0	
79	0h1B4F	FAN Trip Mode	cooling fan failure selection	0 Trip 1 Warning	0:Trip	0		0	0	0	0	0	
80	0h1B50	Opt Trip Mode	movement selection in case of option trip	0 None 1 Free-Run 2 Dec	1: Free-Run	0		10-13	0	0	0	0	0
81	0h1B51	LVT Delay	low voltage failure judgment delay time	0-60.0[sec]	0.0	X		10-13	0	0	0	0	0

* The grey code refers to hidden code, emerging only in case of setting of the code.

Note 36) PRT-10 code is displayed only when PRT-09(Retry Number) is set the value more than "0".

Note 36) PRT-13~15 codes are displayed only when PRT-12(Lost Cmd Mode) is not set as "NONE".

Chapter 8 Table of Functions

8.1.12 Parameter mode – 2nd motor function Group (→M2)

2nd motor function Group (PAR → M2)

No.	Communication No.	Function Display	Name	Setting Range	Initial Value	Shift in Operation	Page	Control Mode				
								V/F	S/L	V/C	S/L/T	V/C/T
00	-	Jump Code	jump code	0-99	14	0		0	0	X	0	X
04	0h1C04	M2-Acc Time	accelerating time	0-600[sec]	Below 75kW 20.0 Above 90kW 60.0	0		0	0	X	0	X
05	0h1C05	M2-Dec Time	decelerating time	0-600[sec]	Below 75kW 30.0 Above 90kW 90.0	0		0	0	X	0	X
06	0h1C06	M2-Capacity	motor capacity	0~ 0.2kW 21 185kW	-	X		0	0	X	0	X
07	0h1C07	M2-Base Freq	base frequency	30-400[Hz]	60.00	X		0	0	X	0	X
08	0h1C08	M2-Ctrl Mode	control mode	0 V/F 1 V/F PG 2 Slip Compen 3 Sensorless-1 4 Sensorless-2	0:V/F	X		0	0	X	0	X
10	0h1C0A	M2-Pole Num	motor pole	2-48		X		0	0	X	0	X
11	0h1C0B	M2-Rated Slip	rated sleep speed	0-3000[rpm]		X		0	0	X	0	X
12	0h1C0C	M2-Rated Curr	motor rated current	1-200[A]		X	8-40	0	0	X	0	X
13	0h1C0D	M2-No-load Curr	motor no load current	0.5-200[A]		X		0	0	X	0	X
14	0h1C0E	M2-Rated Volt	motor rated voltage	180-220[V]		X		0	0	X	0	X
15	0h1C0F	M2-Efficiency	motor efficiency	70-100[%]	Depends on motor capacity	X						
16	0h1C10	M2-Inertia Rt	load inertia ratio	0-8		X		0	0	X	0	X
17	-	M2-Rs	stator resistance	0-9.999[Ω]		X						
18	-	M2-Lsigma	leak inductance	0-99.99[mH]		X						
19	-	M2-Ls	stator inductance	0-999.9[mH]		X		0	0	X	0	X
20	-	M2-Tr	rotor time constant	25-5000[msec]		X		0	0	X	0	X
25	0h1C19	M2-V/F Patt	V/F pattern	0 Linear 1 Square 2 User V/F	0:Linear	X		0	0	X	0	X
26	0h1C1A	M2-Fwd Boost	forward torque boost		Below 75kW: 2.0	X		0	0	X	0	X
27	0h1C1B	M2-Rev Boost	reverse torque boost		Above 90kW: 1.0	X		0	0	X	0	X
28	0h1C1C	M2-Stall Lev	stall preventing level	30-150[%]		X		0	0	X	0	X
29	0h1C1D	M2-ETH 1min	electric thermal 1 minute rating	100-200[%]	150	X		0	0	X	0	X
30	0h1C1E	M2-ETH Cont	electric thermal consecutive rated	50-150[%]	100	X		0	0	X	0	X
40	0h1C28	M2-LoadSpdGain	revolution display gain	0.1-6000.0%	100.0	0		0	0	0	0	0
41	0h1C29	M2-LoadSpdScal	revolution display scale	0 x1 1 x0.1 2 x0.01 3 x0.001 4 x0.0001	0x1	0	8-41	0	0	0	0	0
42	0h1C2A	M2-LoadSpdUnit	revolution display unit	0 rpm 1 r/min	0rpm	0		0	0	0	0	0

8.1.13 Trip mode (TRP current (or Last-x))

Trip Mode (TRP Last-x)

No.	Function Display	Name	Setting Range	Initial Value	Page
00	Trip Name (x)	failure type display	-	-	96
01	Output Freq	operation frequency in case of failure	-	-	
02	Output Current	output current in case of failure	-	-	
03	Inverter State	Acc/Dec status in case of failure	-	-	
04	DCLink Voltage	DC voltage	-	-	
05	Temperature	NTC temperature	-	-	
06	DI State	status of input terminals	-	0000 0000	
07	DO State	status of output terminals	-	000	
08	Trip On Time	failure time since power on	-	000000 00:00	
09	Trip Run Time	failure time since start to run	-	000000 00:00	
10	Trip Delete?	deletion of failure history	0	No	0: No
			1	Yes	

8.1.14 Config Mode (CNF)

Config Mode (CNF)

No.	Function Display	Name	Setting Range	Initial Value	Page	
00	Jump Code	jump code	0-99	1	-	
01	Language Sel	keypad language selection	0	English	0: English	9-15
			1	Pyccae		
			2	Español		
			3	Italiano		
4	TURKISH					
02	LCD Contrast	LCD brightness adjustment	-	-	8-8	
10	Inv SW Ver	body SW version	-	1XX		
11	KeypadSW Ver	keypad SW version	-	1XX		
12	KPD Title Ver	keypad SW version	-	1XX		
20 hold	Anytime Para	status display item	0	Frequency	0: Frequency	9-3
21	Monitor Line-1	monitor mode display item1	1	Speed	0: Frequency	9-1-
22	Monitor Line-2	monitor mode display item2	2	Output Current	2 Output Current	
23	Monitor Line-3	monitor mode display item3	3	Output Voltage	3 Output Voltage	
			4	Output Power		

Chapter 8 Table of Functions

No.	Function Display	Name	Setting Range	Initial Value	Page	
			5	WHour Counter		
			6	DCLink Voltage		
			7	DI State		
			8	DO State		
			9	V1 Monitor[V]		
			10	V1 Monitor[%]		
			11	I1 Monitor[mA]		
			12	I1 Monitor[%]		
			13	V2 Monitor[V]		
			14	V2 Monitor[%]		
			15	I2 Monitor[mA]		
			16	I2 Monitor[%]		
			17	PID Output		
			18	PID Ref Value		
			19	PID Fdb Value		
			20	Torque		
			21	Torque Limit		
			22	Trq Bias Ref		
			23	Speed Limit		
			24	Load Speed		
24	Mon Mode Init	monitor mode initialization	0	No	9-1	
			1	Yes		
30	Option-1 Type	option slot 1 type display	0	None	Option	
31	Option-2 Type	option slot 2 type display	1	PLC		
32	Option-3 Type	option slot 3 type display	2	Prof		
			3	Ext. I/O		
			4	Encoder	0: None	
40	Parameter Init	parameter initialization	0	No	-	8-43
			1	All Grp		
			2	DRV Grp		
			3	BAS Grp		
			4	ADV Grp		
			5	CON Grp		
			6	IN Grp		
			7	OUT Grp		
			8	COM Grp		
			9	APP Grp		
			10	AUT Grp		
			11	APO Grp		
			12	PRT Grp		
			13	M2 Grp		

No.	Function Display	Name	Setting Range		Initial Value	Page
41	Changed Para	changed parameter display	0	View All	0: View All	8-45
			1	View Changed		
42	Multi Key Sel	multi-function key item	0	None	0: None	8-45
			1	JOG Key		
			2	Local/Remote		
			3	UserGrp SelKey		
43	Macro Select	macro function item	0	None	0: None	8-47
			1	Draw App		
			2	Traverse		
44	Erase All Trip	deletion of failure history	0	No	0: No	8-48
			1	Yes		
45	UserGrp AllDel	deletion user registration code	0	No	0: No	8-45
			1	Yes		
46	Parameter Read	parameter reading	0	No	0: No	8-43
			1	Yes		
47	Parameter Write	parameter writing	0	No	0: No	8-43
			1	Yes		
48	Parameter Save	communication parameter saving	0	No	0: No	8-43
			1	Yes		
50	View Lock Set	parameter mode hiding	0-9999		Un-locked	8-44
51	View Lock Pw	parameter mode hiding password		Password		
52	Key Lock Set	parameter editing lock			Un-locked	8-44
53	Key Lock Pw	parameter editing lock			Password	
60	Add Title Del	Keypad title version up		0	No	0: No
			1	Yes		
61	Easy Start On	Easy parameter setting	0	No	1: Yes	8-47
			1	Yes		
62	WHCount Reset	consumed power amount initialization	0	No	0: No	8-48
			1	Yes		
70	On-time	inverter movement cumulative time	mm/dd/yy h:mm		-	9-14
71	Run-time	inverter operation cumulative time			-	
72	Time Reset	inverter operation cumulative time initialization	0	No	0: No	
			1	Yes		
74	Fan Time	cooling fan operation cumulative time	mm/dd/yy h:mm		-	
75	Fan Time Rst	cooling fan operation cumulative time initialization	0	No	-	
			1	Yes		

Note 3) Item 7 and 8 are not exist in Anytime Para item

Chapter 8 Table of Functions

8.1.15 User/Macro Mode → MC1

U and M → MC1

No.	Function Display	Name	Setting Range	Initial Value	Page
00	Jump Code	jump code	0-99	1	-
01	Acc Time	accelerating time	0-600(sec)	Below 75kW 20	7-15
		Above 90kW 60			
02	Dec Time	decelerating time		Below 75kW 30	
		Above 90kW 90			
03	Cmd Source	operating command method	0-5	1: Fx/Rx-1	7-11
04	Freq Ref Src	frequency setting method	0-9	2: V1	7-1
05	Control Mode	control mode	0-5	0: V/F	7-20
06	Aux Ref Src	auxiliary command setting method	0-4	2: I1	8-1
07	Aux Calc Type	auxiliary command movement selection	0-7	0	
08	Aux Ref Gain	auxiliary command gain	-200-200(%)	100.0	
09	V1 Polarity	V1 input polar selection	0-1	0: Unipolar	
10	V1 Filter	V1 input filter time constant	0-10000(msec)	10	7-2
11	V1 Voltx1	V1 input minimum voltage	0-10(V)	0.00	
12	V1 Percy1	output% at V1 minimum voltage	0-100(%)	0.00	
13	V1 Voltx2	V1 input maximum voltage	0-10(V)	10.00	
14	V1 Percy2	Output % at V1 maximum voltage	0-100(%)	100.00	
15	V1 -Voltx1	V1 -input minimum voltage	-10-0(V)	0.00	
16	V1 -Percy1	output% at V1 -minimum voltage	-100-0(%)	0.00	
17	V1 -Voltx2	V1 -input maximum voltage	-10-0(V)	-10.00	
18	V1 -Percy2	output% at V1 -maximum voltage	-100-0(%)	-100.00	
19	V1 Inverting	rotation direction change	0-1	0: No	
20	I1 Monitor(mA)	I1 input amount display	0-20(mA)	0.00	7-5
21	I1 Polarity	I1 polarity display	0-1	0	
22	I1 Filter	I1 input filter time constant	0-10000(msec)	10	
23	I1 Currx1	I1 input minimum current	0-20(mA)	4.00	
24	I1 Percy1	Output% at I1 minimum current	0-100(%)	0.00	
25	I1 Currx2	I1 input maximum current	4-20(mA)	20.00	
26	I1 Percy2	output% at I1 maximum current	0-100(%)	100.00	
27	I1 Currx1	I1 -Input minimal current	-20-0(mA)	0.00	
28	I1 Percy1	Output %at I1 - minimal current	-100-0(%)	0.00	
29	I1 Currx2	I1 - Input maximum current	-20-0(mA)	-20.00	
30	I1 Percy2	Output% at I1 maximum current	-100-0(%)	-100.00	
31	I1 Inverting	rotation direction change	0-1	0: No	
32	P1 Define	P1 terminal function setting	0-48	0: FX	7-11
33	P2 Define	P2 terminal function setting		1: RX	
34	P3 Define	P3 terminal function setting		5: BX	

8.1.16 User/Macro mode – Traverse operation function group (→MC2)

Traverse operation function Group (U and M → MC2)

No.	Function Display	Name	Setting Range	Initial Value	Page
00	Jump Code	Jump code	0-99	1	-
01	Acc Time	accelerating time	0-600[sec]	Below 75kW 20	8-61
		Above 90kW 60			
02	Dec Time	decelerating time		Below 75kW 30	
		Above 90kW 90			
03	Cmd Source	operating command method	0-5	1: Fr/Rc-1	
04	Freq Ref Src	frequency setting method	0-9	0: Keypad-1	
05	Control Mode	control mode	0-5	0: V/F	
06	App Mode	applied function selection	0-4	1: Traverse	
07	Trv Apmitt %	traverse operating range	0-20[%]	0.0	
08	Trv Scramb %	traverse scramble magnitude	0-50[%]	0.0	
09	Trv Acc Time	traverse accelerating time	0.1-600[sec]	2.0	
10	Trv Dec Time	traverse decelerating time		3.0	
11	Trv Offset Hi	traverse offset upper limit	0-20[%]	0.0	
12	Trv Offset Lo	traverse offset lower limit		0.0	
13	P1 Define	P1terminal function setting	0-48	0: FX	
14	P2 Define	P2terminal function setting		1: RX	
15	P3 Define	P3terminal function setting		5: BX	
16	P4 Define	P4terminal function setting		27: Trv	
17	P5 Define	P5terminal function setting		28: Trv	

M E M O

A large rectangular area with horizontal dashed lines, intended for writing a memo.

EC DECLARATION OF CONFORMITY

We, the undersigned,

Representative: **LS Industrial Systems Co., Ltd.**
Address: **LS Tower, Hogye-dong, Dongan-gu,
Anyang-si, Gyeonggi-do 1026-6,
Korea**

Manufacturer: **LS Industrial Systems Co., Ltd.**
Address: **181, Samsung-ri, Mokchon-Eup,
Chonan, Chungnam, 330-845,
Korea**

Certify and declare under our sole responsibility that the following apparatus:

Type of Equipment: **Inverter (Power Conversion Equipment)**

Model Name: **STARVERT-iS7 series**

Trade Mark: **LS Industrial Systems Co., Ltd.**

conforms with the essential requirements of the directives:

2006/95/EC Directive of the European Parliament and of the Council on the harmonisation of the laws of Member States relating to Electrical Equipment designed for use within certain voltage limits

2004/108/EC Directive of the European Parliament and of the Council on the approximation of the laws of the Member States relating to electromagnetic compatibility

based on the following specifications applied:

**EN 61800-3:2004
EN 50178:1997**

and therefore complies with the essential requirements and provisions of the 2006/95/CE and 2004/108/CE Directives.

Place: **Chonan, Chungnam,
Korea**

 06/02/2009

(Signature /Date)

Mr. Dok Ko Yong Chul/Factory Manager
(Full name / Position)

TECHNICAL STANDARDS APPLIED

The standards applied in order to comply with the essential requirements of the Directives 2006/95/CE "Electrical material intended to be used with certain limits of voltage" and 2004/108/CE "Electromagnetic Compatibility" are the following ones:

• EN 50178 (1997)	"Electronic equipment for use in power installations".
• EN 61800-3 (2004)	"Adjustable speed electrical power drive systems. Part 3: EMC product standard including specific methods"
• EN 55011/A2 (2003)	"Industrial, scientific and medical (ISM) radio-frequency equipment. Radio disturbances characteristics. Limits and methods of measurement"
• EN61000-4-2/A2 (2001)	"Electromagnetic compatibility (EMC). Part 4: Testing and measurement techniques. Section 2: Electrostatic discharge immunity test.
• EN61000-4-3/A2 (2004)	"Electromagnetic compatibility (EMC). Part 4: Testing and measurement techniques. Section 3: Radiated, radiofrequency, electromagnetic field immunity test.
• EN61000-4-4/A2 (2002)	"Electromagnetic compatibility (EMC). Part 4: Testing and measurement techniques. Section 4: Electrical fast transients / burst immunity test.
• EN61000-4-5/A1 (2001)	"Electromagnetic compatibility (EMC). Part 4: Testing and measurement techniques. Section 5: Surge immunity test.
• EN61000-4-6/A1 (2001)	"Electromagnetic compatibility (EMC). Part 4: Testing and measurement techniques. Section 6: Immunity to conducted disturbances, induced by radio-frequency fields.
• CEI/TR 61000-2-1 (1990)	"Electromagnetic compatibility (EMC). Part 2: Environment. Environment description for low-frequency conducted disturbances and signalling in public low voltages supply systems"
• EN 61000-2-2 (2003)	"Electromagnetic compatibility (EMC). Part 2: Environment. Compatibility level for low-frequency conducted disturbances and signalling in public low voltages supply systems"
• EN 61000-2-4 (1997)	"Electromagnetic compatibility (EMC). Part 2: Environment. Compatibility level in industrial plants for low-frequency conducted disturbances"
• EN60146-1-1/A1 (1998)	"Semiconductor converters. General requirements and line commutated converters. Part 1-1: Specifications of basic requirements"

EMI / RFI POWER LINE FILTERS

LS inverters, IS7 series



RFI FILTERS

THE LS RANGE OF POWER LINE FILTERS FF (Footprint) - FE (Standard) SERIES, HAVE BEEN SPECIFICALLY DESIGNED WITH HIGH FREQUENCY LG INVERTERS. THE USE OF LS FILTERS, WITH THE INSTALLATION ADVICE OVERLEAF HELP TO ENSURE TROUBLE FREE USE ALONG SIDE SENSITIVE DEVICES AND COMPLIANCE TO CONDUCTED EMISSION AND IMMUNITY STANDARDS TO EN 50081.

CAUTION

IN CASE OF A LEAKAGE CURRENT PROTECTIVE DEVICES IS USED ON POWER SUPPLY, IT MAY BE FAULT AT POWER-ON OR OFF. IN AVOID THIS CASE, THE SENSE CURRENT OF PROTECTIVE DEVICE SHOULD BE LARGER THAN VALUE OF LAKAGE CURRENT AT WORST CASE IN THE BELOW TABLE.

RECOMMENDED INSTALLATION INSTRUCTIONS

To conform to the EMC directive, it is necessary that these instructions be followed as closely as possible. Follow the usual safety procedures when working with electrical equipment. All electrical connections to the filter, inverter and motor must be made by a qualified electrical technician.

- 1-) Check the filter rating label to ensure that the current, voltage rating and part number are correct.
- 2-) For best results the filter should be fitted as closely as possible to the incoming mains supply of the wiring enclosure, usually directly after the enclosures circuit breaker or supply switch.
- 3-) The back panel of the wiring cabinet of board should be prepared for the mounting dimensions of the filter. Care should be taken to remove any paint etc... from the mounting holes and face area of the panel to ensure the best possible earthing of the filter.
- 4-) Mount the filter securely.
- 5-) Connect the mains supply to the filter terminals marked **LINE**, connect any earth cables to the earth stud provided. Connect the filter terminals marked **LOAD** to the mains input of the inverter using short lengths of appropriate gauge cable.
- 6-) Connect the motor and fit the ferrite core (output chokes) as close to the inverter as possible. Armoured or screened cable should be used with the 3 phase conductors only threaded twice through the center of the ferrite core. The earth conductor should be securely earthed at both inverter and motor ends. The screen should be connected to the enclosure body via and earthed cable gland.
- 7-) Connect any control cables as instructed in the inverter instructions manual.

IT IS IMPORTANT THAT ALL LEAD LENGTHS ARE KEPT AS SHORT AS POSSIBLE AND THAT INCOMING MAINS AND OUTGOING MOTOR CABLES ARE KEPT WELL SEPARATED.

FE SERIES (Standard)



IS7 series / Standard Filters

INVERTER	POWER	CODE	CURRENT	VOLTAGE	SEAWAVE CURRENT	DIMENSIONS L W H	MOUNTING Y X	WEIGHT	MOUNT	FIG.	OUTPUT CHOKE
THREE PHASE						NOM. MAR.					
SV9300B7-4	30kW	FE-T070(x)	70A	380VAC	1.3mA 10mA	350 x 180 x 90	338 x 148	7.5 Kg	—	A	FS-3
SV9370B7-4	37kW	FE-T100(x)	100A	380VAC	1.3mA 10mA	425 x 200 x 130	408 x 198	13.8 Kg	—	A	FS-3
SV9450B7-4	45kW	FE-T120(x)	120A	380VAC	1.3mA 10mA	425 x 200 x 130	408 x 198	13.8 Kg	—	A	FS-3
SV9550B7-4	55kW	FE-T170(x)	170A	380VAC	1.3mA 10mA	480 x 200 x 180	468 x 198	18 Kg	—	A	FS-3
SV9600B7-4	60kW	FE-T200(x)	200A	380VAC	1.3mA 10mA	580 x 250 x 205	560 x 170	23.5 Kg	—	A	FS-4
SV1100B7-4	110kW	FE-T400(x)	400A	380VAC	1.3mA 10mA	392 x 280 x 118	240 x 235	10.3 Kg	—	B	FS-4
SV1320B7-4	132kW	FE-T400(x)	400A	380VAC	1.3mA 10mA	392 x 280 x 118	240 x 235	10.3 Kg	—	B	FS-4

- (x) (1) Industrial environment EN50061-2 (A class)
 (2) Domestic and Industrial environment EN50061-1 (B class)

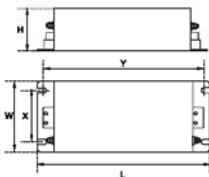
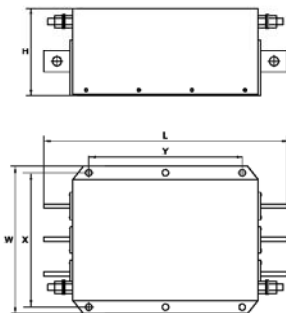
FE SERIES (Standard)
FIG.A

FIG.B

LS VMC
 vector motor control

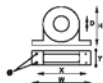
Vector Motor Control Ibérica S.L.
 C/ Mar del Carbó, 10
 Pol. Ind. La Torre del Rector
 08130 Santa Perpètua de Mogoda
 (BARCELONA) ESPAÑA
 Tel. (+34) 935 748 206
 Fax: (+34) 935 748 248
 info@vmc.es
 www.vmc.es

FS SERIES (output chokes)

CODE	B	W	H	X	Y
FS-3	48	180	110	125 x 30	0
FS-4	58	230	170	160 x 45	0

PRO002

Warranty

Maker	LS Industrial Systems Co., Ltd.	Installation (Start-up) Date	
Model No.	SV-IS7	Warranty Period	
Customer Information	Name		
	Address		
	Tel.		
Sales Office (Distributor)	Name		
	Address		
	Tel.		

Warranty period is 12 months after installation or 18 months after manufactured when the installation date is unidentified. However, the guarantee term may vary on the sales term.

IN-WARRANTY service information

If the defective part has been identified under normal and proper use within the guarantee term, contact your local authorized LS distributor or LS Service center.

OUT-OF WARRANTY service information

The guarantee will not apply in the following cases, even if the guarantee term has not expired.

- ▶ Damage was caused by misuse, negligence or accident.
- ▶ Damage was caused by abnormal voltage and peripheral devices' malfunction (failure).
- ▶ Damage was caused by an earthquake, fire, flooding, lightning, or other natural calamities.
- ▶ When LS nameplate is not attached.
- ▶ When the warranty period has expired.

Revision History

Revision History

No	Date	Edition	Version No.	Changes
1	2007.11	First Edition	1.00	-
2	2009.02	2nd Edition	1.10	IP54 contents added
3	2010.04	3rd Edition	1.20	200V contents added



LS values every single customer.
 Quality and service come first at LSIS.
 Always at your service, standing for our customers.

www.lsis.biz

LS Industrial Systems

10310001086

■ **HEAD OFFICE**

Address: LS tower, 1026-6, Hoggje-dong, Dongan-gu, Anyang-si, Gyeonggi-do 431-848, Korea
<http://eng.lsis.biz>

■ **LS Industrial Systems Europe B.V. } Amsterdam, Netherlands**

Address: 1st FL., Tupolevlaan 48, 1119NZ Schiphol-Rijk, The Netherlands
 e-mail: jussticks@sis.biz
 Tel: 31-20-654-1420 Fax: 31-20-654-1429

■ **LS Industrial Systems (Middle East) FZE Office } Dubai, UAE**

Address: LOB 19 Jaiza View Tower Room 205, Jebel Ali Free Zone, P.O.Box 114216, Dubai, UAE.
 e-mail: jungyong@sis.biz
 Tel: 971-4-886-5360 Fax: 971-4-886-5361

■ **Dalian LS Industrial Systems Co., Ltd. } Dalian, China**

Address: No. 15 Liaohexi 3-Road, Economic and Technical Development Zone, Dalian 116600, China
 e-mail: ldx@sis.com.cn
 Tel: 86-411-8273-7777 Fax: 86-411-8730-7560

■ **LS Industrial Systems Wuxi Co., Ltd. } Wuxi, China**

Address: 102-A National High & New Tech Industrial Development Area, Wuxi, Jiangsu 214028, China
 e-mail: xuhg@sis.com.cn
 Tel: 86-510-8534-6666 Fax: 86-510-522-4078

■ **LS-VINA Industrial Systems Co., Ltd. } Hanoi, Vietnam**

Address: Nguyen Khe, Dong Anh, Ha Noi, Vietnam
 e-mail: srio@sisvina.com
 Tel: 84-4-882-0222 Fax: 84-4-882-0220

■ **LS-VINA Industrial Systems Co., Ltd. } Hochiminh, Vietnam**

Address: 41 Nguyen Thi Minh Khai Str, Yoco Bldg 4th FL., Hochiminh City, Vietnam
 e-mail: stoc@sisvina.com
 Tel: 84-8-3822-7941 Fax: 84-4-3822-7942

■ **LS Industrial Systems Tokyo Office } Tokyo, Japan**

Address: 18th FL., Higashi-Kan, Akasaka Twin Tower 17-22, 2-chome, Akasaka, Minato-ku, Tokyo 107-8470, Japan
 e-mail: jachuna@sis.biz

■ **LS Industrial Systems Shanghai Office } Shanghai, China**

Address: Room E-Q, 12th FL., Huamin Empire Plaza, No. 726, West Yan'an Road, Shanghai 200050, China
 e-mail: jinbk@sis.com.cn

■ **LS Industrial Systems Beijing Office } Beijing, China**

Address: B-tower 17th FL., Beijing Global Trade Center B/D, No. 36, BeiSanHuanDong-Lu, DongCheng-District, Beijing 100013, China
 e-mail: cudiaocong@sis.com.cn
 Tel: 86-10-5825-6025, 7 Fax: 86-10-5825-6026

■ **LS Industrial Systems Guangzhou Office } Guangzhou, China**

Address: Room 1403, 14th FL., New Poly Tower, 2 Zhongshan Liu Road, Guangzhou, China
 e-mail: lingz@sis.biz
 Tel: 86-20-8326-6764 Fax: 86-20-8326-6287

■ **LS Industrial Systems Chengdu Office } Chengdu, China**

Address: 12th FL., Guodong Building, No.52 Jindun Road, Chengdu, 610041, P.R. China
 e-mail: yangqi@sis.com.cn
 Tel: 86-28-8612-9151 Fax: 86-28-8612-9236

■ **LS Industrial Systems Qingdao Office } Qingdao, China**

Address: 7B40, Habin Guangchang Shanye B/D B, No. 9, Shan-dong Road, Qingdao 26600, China
 e-mail: lin@sis.com.cn
 Tel: 86-532-8501-6568 Fax: 86-532-563-3793