

GE Consumer & Industrial
Power Protection



VAT200

Instruction Manual



GE imagination at work

Quick Start Guide

This guide is to assist in installing and running the inverter to verify that the drive and motor are working properly. Starting, stopping and speed control will be from the keypad. If your application requires external control or special system programming, consult the VAT200 Instruction Manual supplied with your inverter.

Step 1 Before Starting the Inverter

Please review Preface and Safety Precautions (page 0-1 through 1-3) of the VAT200 Instruction Manual. Verify drive was installed in accordance with the procedures as described in VAT200 Ambient Environment and Installation on pages 3-1 through 3-8. If you feel this was abnormal, do not start the drive until qualified personnel have corrected the situation. (Failure to do so could result in serious injury.)

- **Check inverter and motor nameplates to determine that they have the same HP and voltage ratings. (Ensure that full load motor amps do not exceed that of the inverter.)**
- **Remove the terminal cover to expose the motor and power terminals.**
 - a. Verify that AC power is wired to L1, L2, and L3 (pages 3-12).
 - b. Verify that Motor leads are connected to T1, T2, and T3 (pages 3-12).
(The two leads may need to be reversed if motor rotation is not correct.)



1. **SEQ LED** : 1_00 =1, LED Lit.
2. **FRQ LED** : 1_01 = 1/2/3/4, LED Lit
3. **FWD LED** : Forward Direction, LED action(Flash in stop, Keep Lit in operation).
4. **REV LED** : Reverse Direction, LED action(Flash in stop, Keep Lit in operation).
5. **Four action of FUN, Hz/RPM, VOLT, AMP LED** and display of four 7-segment display, refer to operation description of the keypad.
6. **LCD keypad without FUN, Hz/RPM, VOLT, AMP LED.**

Step 2 Apply Power to the Drive

- **Apply AC power to the Drive and observe Operator. Four 7-segment Display should read Power Voltage for 3~5 seconds and then read Frequency/Speed, 05.00. Four 7-segment Display and FWD LED should be flashed all the time.**

Step 3 Check Motor Rotation Without Load

- **Press RUN key (FWD LED should light); Four 7-segment Display should run from 00.00 to 05.00.**
- **Check motor rotation.**
If it is not correct:
Press STOP key. Remove AC power. Wait for LED “charge” lamp to extinguish.
Reverse motor leads T1 and T2. Restart the drive and check new rotation.
- **Press STOP key to stop the drive.**

Step 4 Check Full Speed at 50Hz/60Hz

- **Frequency/Speed can be changed by pressing the up or down Arrow keys. To move right or left for next digit, press SHIFT / RESET key. Press the READ / ENTER key to set the speed.**
- **Set frequency up to 50Hz/60Hz in accordance with the last rule.**
- **Press RUN key. Check drive acceleration to full speed.**
- **Press STOP key to stop drive and check deceleration.**

Step 5 Other Operations

For information, see VAT200 Instruction Manual.

Please refer to the following pages:

Set Accel	p. 4-11
Set Decel	p. 4-11
Set Max Speed	p. 4-11
Set Min Speed	p. 4-11
Set Motor Rated Current	p. 4-9
Set Control Mode (Vector, V/F)	p. 4-7

Table of Content

Quick Start Guide		i
Chapter 0	Preface	0-1
0.1	Preface	0-1
0.2	Products Inspection	0-1
Chapter 1	Safety Precautions	1-1
1.1	Operation Precaution	1-1
1.1.1	Before Power ON	1-1
1.1.2	During Power ON	1-2
1.1.3	Before Operation	1-2
1.1.4	During Operation	1-3
1.1.5	During Maintenance	1-3
Chapter 2	Definition of Model	2-1
Chapter 3	Ambient Environment and Installation	3-1
3.1	Environment	3-1
3.2	Environmental Precautions	3-2
3.3	Inflammable Materials	3-3
3.3.1	Notice for Wiring	3-3
3.3.2	Applicable Specification of Magnetic Contactor and Wires	3-5
3.3.3	Precautions for Peripheral Applications	3-6
3.4	Specifications	3-9
3.4.1	Products Individual Specifications	3-9
3.4.2	General Specifications	3-10
3.5	Wiring Diagram VAT200 Series Inverter	3-12
3.6	Description of Terminals Troubleshooting Inverter	3-13
3.7	Outline Dimension	3-15
Chapter 4	Software Index	4-1
4.1	Keypad Description	4-1
4.1.1	Keypad Display and Operation Instruction	4-1
4.1.2	Operation Instruction of the Keypad	4-2
4.1.3	Operation Instruction of the LED Keypad	4-3
4.1.4	Operation Instruction of the LCD Keypad	4-4
4.1.5	Keypad Operating Example	4-5
4.2	Control Mode Selection	4-7
4.3	VAT200 Programmable Functions List	4-8
4.4	Parameter Function Description	4-20
4.5	Specification Description on Built-in PLC Function	4-55
4.5.1	Basic Instruction	4-55
4.5.2	Function of Basic Instruction	4-56
4.5.3	Application Instructions	4-57
Chapter 5	Troubleshooting and Maintenance	5-1
5.1	Error Display and Remedy	5-1
5.1.1	Error Which can not be Recovered Manually	5-1
5.1.2	Special Conditions	5-4
5.1.3	Operation Errors	5-5
5.2	General Troubleshooting	5-6
5.3	Quick Troubleshooting VAT200 Series	5-7
5.4	Routine Inspection and Period Inspection	5-13
5.5	Maintenance and Inspection	5-14
Chapter 6	Peripheral Components	6-1

6.1	Reactor Specification at Input Side	6-1
6.2	Reactor Specification at DC Side	6-1
6.3	Braking Resistor	6-2
6.4	Digital Operator and Extension Cable	6-3
6.5	EMC Filter	6-5
6.6	Interface Card	6-7
	6.6.1 RS-485 Interface Card	6-7
	6.6.2 RS-232 Interface Card	6-8
	6.6.3 Program Copy Unit	6-9
Appendix I	VAT200 Motor Internal Parameter List	App1
Appendix II	VAT200 Parameters Setting List	App2

Chapter 0 Preface

0.1 Preface

To extend the performance of the product and ensure your safety, please read this manual thoroughly before using the inverter. Should there be any problem in using the product and can not be solved with the information provided in the manual, contact your nearest GE's distributor or our sales representatives who will be willing to help you. Please keep using GE's products in the future.

※Precautions

The inverter is an electrical electronic product. For your safety, there are symbols such as "Danger", "Caution" in this manual to remind you to pay attention to safety instructions on handling, installing, operating, and checking the inverter. Be sure to follow the instructions for highest safety.



Danger

Indicates a potential hazard could cause death or serious personal injury if misused.

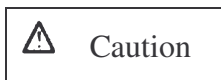

Caution

Indicates that the inverter or the mechanical system might be damaged if misused.

⚠ Danger

- Do not touch any circuit boards or components if the charging indicator is still lit after turned the power off.
- Do not wire when the inverter is electrified. Do not check parts and signals on circuit boards during the inverter operation.
- Do not disassemble the inverter and modify internal wires, circuits and parts.

Ground the ground terminal of the inverter properly. As for 200V class ground to 100 Ω or below, 400v class ground to 10Ω or below.

⚠ Caution

- Do not perform a voltage test on parts inside the inverter. High voltage will easily destroy these semiconductor parts.
- Do not connect T1 (U), T2 (V), and T3 (W) terminals of the inverter to AC power supply.
- CMOS ICs on the inverter's main board are susceptible to static electricity. Do not touch the main circuit board

0.2 Products Inspection

GE's inverters are all passed the function test before delivery. Please check the followings when you received and unpacked the inverter:

- The model and capacity of the inverter are the same as those specified in your purchase order.
- Check where there are any damages caused by transportation. Please do not apply the power, and do contact GE's sales representatives if any of the above problems happened.

Chapter 1 Safety Precautions

1.1 Before Using the Product

1.1.1 Before Power ON

Caution

The line voltage applied must comply with the inverter's specified input voltage.

Danger

Make sure the main circuit connections are correct. L1(L), L2 and L3(N) are power-input terminals and must not be mistaken for T1, T2 and T3. Otherwise, the inverter might be damaged.

Caution

- To avoid the front cover from disengaging, do not pull the cover during handling for the heat sink should be fallen off. Accident falling down will damage the inverter or injure to person, which should be avoided.
- To avoid the risk of fire, do not install the inverter on a flammable object. Install it on nonflammable object such as metal.
- If several inverters are placed in the same control panel, add extra heat sink to keep the temperature below 40□ to avoid overheat or fire.
- When removing or installing the operator, turn OFF the power first, and manipulate the operator following the instruction of the diagram to avoid operator error or no display caused by bad contact.

Warning

This is a product of the restricted sales distribution class according to IEC 61800-3. In a domestic environment this product may cause radio interference in which case the user may be required to take adequate measures.

1.1.2 During Power ON

⚠ Danger

- Do not plug or unplug the connectors on the inverter when electrified to avoid the control panel damage resulting from erratic transition voltage surge due to contact bounce.
- When momentary power loss is longer than 2 seconds (the larger of horse power, the longer of time), the inverter does not have enough storage power to control the circuit; Therefore, when power is regenerated, the operation of the inverter is based on the setup of 1-00 / 2-05 and the condition of external switch, this is considered to be 「restart」 in the following paragraphs.
- When the momentary power loss is short, the inverter still has enough storage power to control the circuit. Therefore, when power is regenerated, the inverter will automatically restart depending on the setup of 2-00/2-01.
- When restart the inverter, the operation of the inverter is based on the setup of 1-00 and 2-05 and the condition of external switch (FWD/REV button). Attention: the start operation is irrelevant with 2-00/2-01/2-02/2-03.
 1. When 1-00=0000, the inverter will not automatically run after restart.
 2. When 1-00=0001 and the external switch (FWD/REV button) is OFF, the inverter will not run after restart.
 3. When 1-00=0001, the external switch (FWD/REV button) is ON, and 2-05=0000, the inverter will run automatically after restart. Attention: In the sake of safety, please turn off the external switch (FWD/REV button) after power loss to avoid underling damage to the machine and the human body after sudden regeneration of power.
- To ensure the safety of people and machine, please refer to the description and suggestion of 2-05

1.1.3 Before Operation

⚠ Danger

Make sure the model and capacity are the same as those set by 15-0.

⚠ Caution

The inverter will flash the power voltage set by 0-07 for 5 seconds when applying power.

1.1.4 During Operation

⚠ Danger

Do not engage or disengage the motor during operation. Otherwise, the over-current will cause the inverter to disconnect or the main circuit to burn.

⚠ Danger

- To avoid electric shock, do not take the front cover off during electrifying
- The motor will restart automatically after stop when auto-restart function is on. In this case, do not get close to the machine.
- Note: The stop switch is different from the usage of the emergency stop switch. It must be set first to be effective.

⚠ Caution

- Do not touch heat-generating components such as heat sink and braking resistor.
- The inverter can drive the motor running from low speed to high speed. Verify the allowable capacities range of the motor and the mechanism.
- Note the settings related to the braking reactor.
- Do not check signals on circuit boards while the inverter is running.

⚠ Caution

It is after 5 minutes that disassembling or checking the components could be performed as power supply OFF and the indicator turned off.

1.1.5 During Maintenance

⚠ Caution

The inverter should be used in a non-condensed environment with temperature from -10°C to $+40^{\circ}\text{C}$ and relative humidity of 95% non-condense.

⚠ Caution

When the inverter top cover has removed, it can be used in a non-condensed environment with temperature from -10°C to $+50^{\circ}\text{C}$ and relative humidity of 95%, but the environment should be free from water and metal dust.

Chapter 2 Description of models

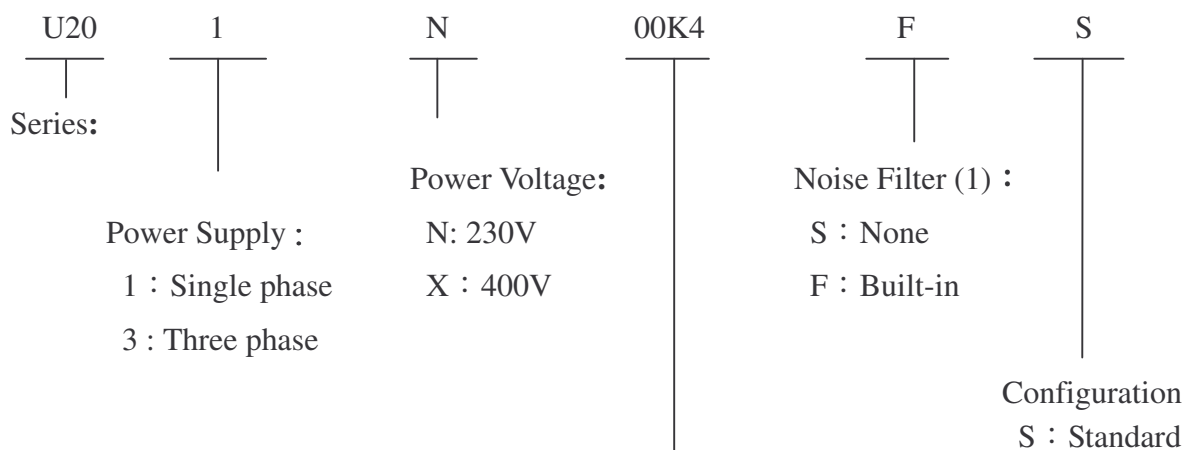
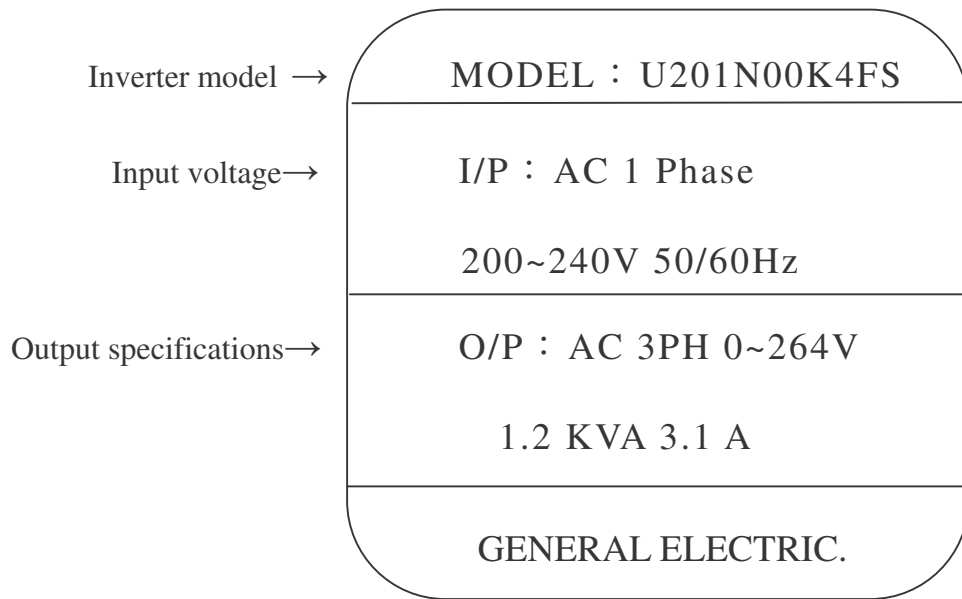

Power KW (2) :

00K4 : 0.4 KW	05K5 : 5.5 KW	22K0 : 22 KW
00K7 : 0.75 KW	07K5 : 7.5 KW	30K5 : 30 KW
01K5 : 1.5 KW	11K0 : 11 KW	37K0 : 37 KW
02K2 : 2.2 KW	15K0 : 15 KW	45K0 : 45 KW
04K0 : 3.7 KW	18K5 : 18.5 KW	55K0 : 55 KW

※Notes:

- 1) Built-in EMC filter not available in three phase 230V, U203N series.
- 2) Maximum power rating allowed
 - Single phase 230V, U201N series: Up to 2.2KW
 - Three phase 230V, U203N series: Up to 7.5 KW
 - Three phase 400V, U203X series: Up to 55 KW

Chapter 3 Ambient Environment and Installation

3.1 Environment

The environment will directly affect the proper operation and the life span of the inverter, so install the inverter in an environment complying with the following conditions:

- Ambient temperature: -10°C - $+40^{\circ}\text{C}$; without cover: -10°C - $+50^{\circ}\text{C}$
- Avoid exposure to rain or moisture.
- Avoid oil mist and salinity.
- Avoid dust, bats, and small metal pieces.
- Avoid electromagnetic interference (soldering machine, power machine).
- Avoid vibration (punching machine). Add a vibration-proof pad if the situation cannot be avoided.
- If several inverters are placed in the same control panel, add extra heat sinks to keep the temperature below 40°C .
- Avoid direct sunlight.
- Avoid erosive liquid and gas.
- Keep away from radioactive and flammable materials.

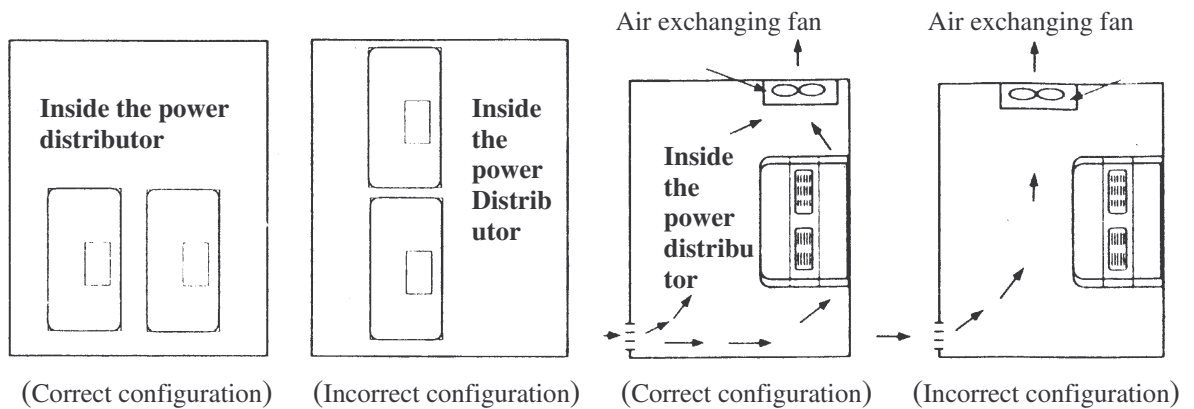

- Place the front side of the inverter onward and top upward to in favor of heat sink.
 - Install the inverter according to the following figures: (take the dustproof cover off in favor of heat sinking if it is installed in a box or the environment allows to do so)

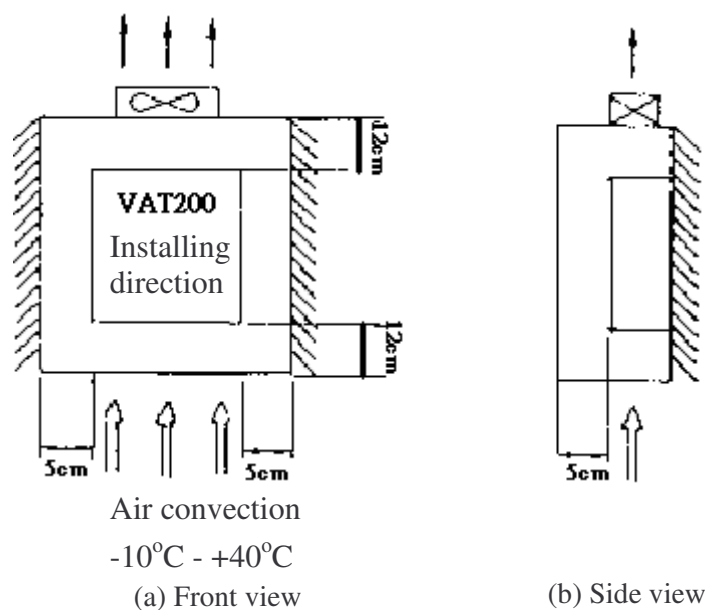

3.2 Environmental precautions

Do not use the inverter in an environment with the following conditions:

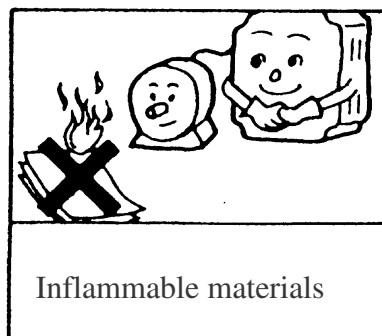
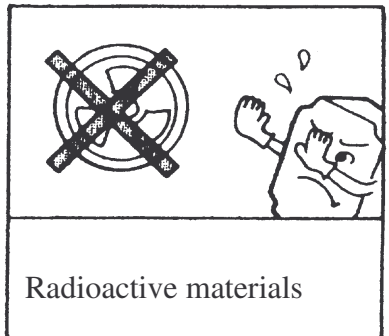
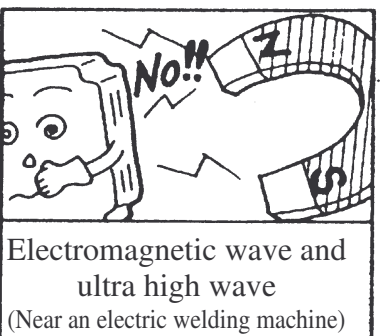
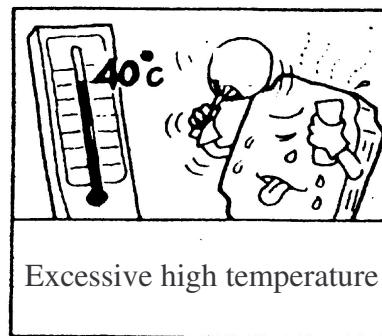
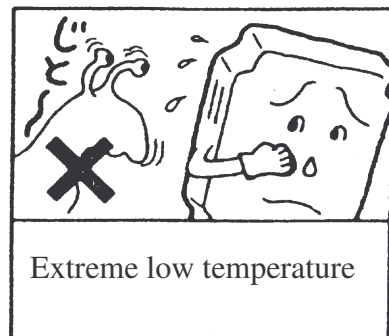
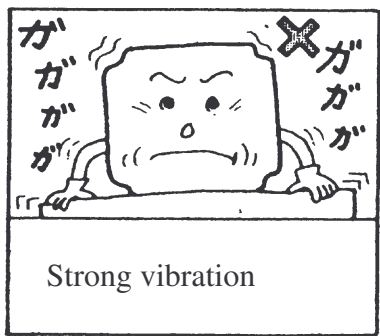
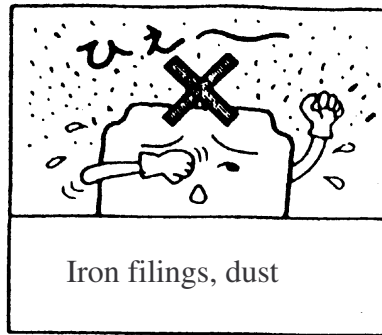
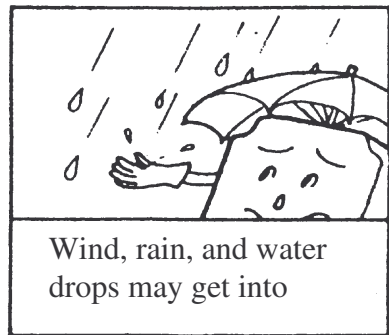
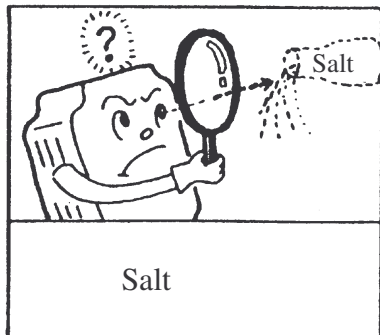
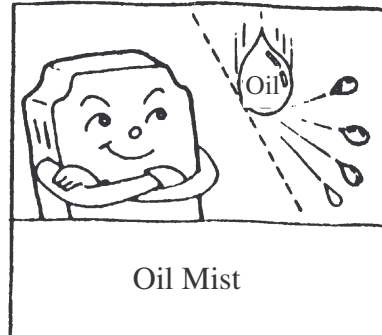
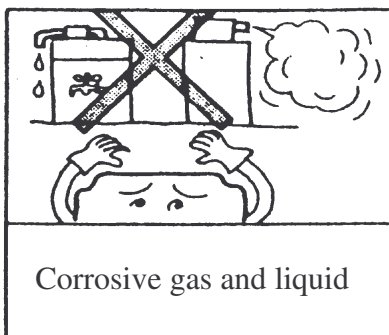
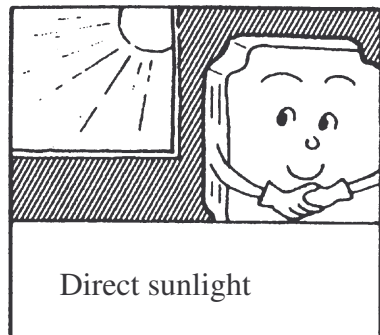

3.3 Inflammable materials

3.3.1 Notice for wiring

A. Screwdriver torque:

Wiring with a screwdriver or other tools and follow the torque listed below:

Securing torque			
Range KW	Power source	Nominal torque for TM1 terminal	
0.4/0.75/1.5(3 ϕ)	200-240V	0.59/0.08 (LBS-FT / KG-M)	7.10/8.20 (LBS-IN/KG-CM)
0.75/ 1.5	380-480V		
1.5(1 ϕ)/2.2/3.7/5.5/7.5	200-240V	1.5/0.21 (LBS-FT/KG-M)	18.00/20.28 (LBS-IN/KG-CM)
2.2/3.7/5.5/7.5/11	380-480V		
15/18.5/22	380-480V	1.84/0.3 (LBS-FT / KG-M)	22.1/30 (LBS-IN/KG-CM)
30/37/45/55	380-480V	4.42/0.66 (LBS-FT/KG-M)	53.1/66 (LBS-IN/KG-CM)

B. Power wires:

Power wires are connecting to L1, L2, L3, T1, T2, T3, P, BR and P1. Choose wires in accordance with the following criteria:

- (1) Use copper wires only. Deciding diameters of wires should be based on rating working at 105°C.
- (2) For rating voltage of wires, the minimum voltage of 230VAC type is 300V, and 460VAC type is 600V.
- (3) For safety reason, the power wires should be fixed by type terminal.

C. Control wires:

Control wires are wires connecting to TM2 control terminal. Choose the wire in accordance with the following criteria:

- (1) Use copper wires only. Deciding diameters of wires should be based on rating working at 105°C.
- (2) For rating voltage of wires, the minimum voltage of 230VAC type is 300V, and 460VAC type is 600V.
- (3) To avoid noise interference, do not route the control wires in the same conduit with power wires and motor wires.

D. Nominal electrical specifications of the terminals Block:

The following list is nominal values of TM1:

Range KW	Power source	Volts	Amps
0.4/0.75/1.5(3 ϕ)	200-240V	600	15A
0.75/1.5	380-480V		
1.5(1 ϕ)/2.2/3.7/5.5/7.5	200-240V		40A
2.2/3.7/5.5/7.5/11	380-480V		
15/18.5/22	380-480V		60A
30/37	380-480V		100A
45/55	380-480V		150A

※Note: Nominal values of input and output signals (TM2) – follow the specifications of class 2 wiring.

E. Fuse types

Drive input fuses are provided to disconnect the drive from power in the event that a component fails in the drive's power circuitry. The drive's electronic protection circuitry is designed to clear drive output short circuits and ground faults without blowing the drive input fuses. Below table shows the VAT200 input fuse ratings.

To protect the inverter most effectively, use fuses with current-limit function.

RK5, C/T TYPE FUSE FOR VAT200**220V class(1 ϕ)**

U201N-	HP	KW	KVA	100% CONT Output AMPS (A)	Max.kk5 FUSE Rating(A)	Max.CC or T FUSE Rating(A)
00K4	0.5	0.4	1.2	3.1	10	20
00K7	1	0.75	1.7	4.5	15	30
01K5	2	1.5	2.9	7.5	20	40
02K2	3	2.2	4.0	10.5	25	50

220v class(3 ϕ)

U203N-	HP	KW	KVA	100% CONT Output AMPS (A)	Max.kk5 FUSE Rating(A)	Max.CC or T FUSE Rating(A)
00K4	0.5	0.4	1.2	3.1	8	10
00K7	1	0.75	1.7	4.5	12	15
01K5	2	1.5	2.9	7.5	15	20
02K2	3	2.2	4.0	10.5	20	30
04K0	5	3.7	6.7	17.5	30	50
05K5	7.5	5.5	9.9	26	50	60
07K5	10	7.5	13.3	35	60	70

440 class(3 ϕ)

U203X-	HP	KW	KVA	100% CONT Output AMPS (A)	Max.kk5 FUSE Rating(A)	Max.CC or T FUSE Rating(A)
00K7	1	0.75	1.7	2.3	6	10
01K5	2	1.5	2.9	3.8	10	15
02K2	3	2.2	4.0	5.2	10	20
04K0	5	3.7	6.7	8.8	20	30
05K5	7.5	5.5	9.9	13	25	35
07K5	10	7.5	13.3	17.5	30	50
11K0	15	11.0	20.6	25	50	60
15K0	20	15.0	27.4	32	60	70
18K5	25	18.5	34.0	40	70	80
22K0	30	22.0	41.0	48	80	100
30K5	40	30.0	54.0	64	100	125
37K0	50	37.0	68.0	80	125	150
45K0	60	45.0	82.0	96	150	200
55K0	75	55.0	110.0	128	200	250

*Fuse ratings are based upon 250V fuses for 230V inverter, and 600V for 460V inverters
For UL, apply UL Designated Class RK5 (delay type fuses), CC or T (non delay fuses)

※Notice

- To avoid shock hazards, do not touch any electrical component when the power is applied or just after five minutes the power plug is unplugged. The other action should be performed after the charge indicator went off.
- Do not perform wiring on the inverter while it is still electrified. Disregard of this notice could cause serious injury or death to persons.

※This product is designed to use in Pollution Degree 2 environment or equivalent environments.

3.3.2 Applicable specification of magnetic contactor and wires

Molded-case circuit breaker/magnetic contactor

- GE bears no responsibility to service for failures caused by the following conditions:
 - (1) A molded-case circuit breaker is not installed, or an improper or overrated breaker is used, between the power source and the inverter.
 - (2) A magnetic contactor, a phase capacitor, or a burst absorber is connected between the inverter and the motor.

VAT200 model	N00K4	N00K7	N01K5	N02K2	N04K0	N05K5	N07K5
Molded-case circuit breaker made by GE	GPS2M_AM 16A	GPS2M_AN 20A	GPS2M_AR 32A	GPS2M_AR 32A	GPS2M_AR 32A	GPS2M_AT 50A	GPS2M_AU 63A
Magnetic contactor (MC) made by GE	CL00	CL01	CL01	CL02	CL25	CL04	CL45
Main circuit terminals (TM1)	Wire gauge 2.0 mm ²			Wire gauge 3.5 mm ²		Wire gauge 5.5 mm ²	
Signal terminals (TM2)	Wire gauge 0.75mm ² (# 18 AWG)						

VAT200 model	X00K7, X01K5, X02K2, X04K0,	X05K5	X07K5	X11K0	X15K0	X18K5	X22K0	X30K0	X37K0	X45K0	X55K0
Molded-case circuit breaker made by GE	GPS2M_AM 16A	_AN 20A	_AR 32	_AT 50A	_AT 50A	FD 80A	FD 100A	FD 100A	FD 125A	FD 100A	FE 200A
Magnetic contactor (MC) made by GE	CL00 CL01 for X04K0	CL02	CL25	CL04	CL45	CL06	CL06	CL07	CL08	CL09	CK75
Main circuit terminals (TM1)	Wire gauge 2.0mm ²	Wire gauge 3.5mm ²	Wire gauge 5.5mm ²	Wire gauge 8mm ²	Wire gauge 14mm ²	Wire gauge 22mm ²	Wire gauge 38mm ²	Wire gauge 60mm ²			
Signal terminals (TM2)	Wire gauge 0.75mm ² (# 18 AWG), terminal screw M3										

- Use three-phase cage induction motor with capacity suitable for the inverter.
- One inverter is driving several motors, the total current of all motors running simultaneously must be less than the rated current of the inverter, and each motor has to be equipped with a proper thermal relay.
- Do not add capacitive component, such as a phase capacitor, LC or RC, between the inverter and the motor.

3.3.3 Precautions for peripheral applications:

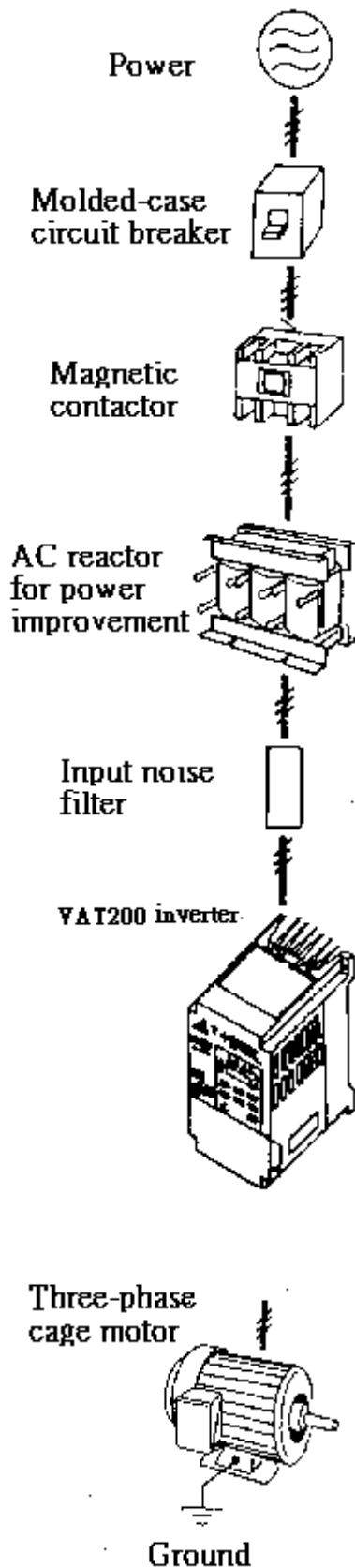

Power supply:

- Make sure the voltage applied is correct to avoid damaging the inverter.
- A molded-case circuit breaker must be installed between the AC source and the inverter

Molded-case circuit breaker:

- Use a molded-case circuit breaker that conforms to the rated voltage and current of the inverter to control the power ON/OFF and protect the inverter.
- Do not use the inverter as the switch for run/stop switch.

Leakage breaker:

- Install a leakage breaker to prevent error operation caused by electric leakage and to protect operators
- Setting current should be 200mA or above and the operating time at 0.1 second or longer to prevent malfunction.

Magnetic contactor:

- Normal operations do not need a magnetic contactor. But a contactor has to be installed in primary side when performing functions such as external control and auto restart after power failure, or when using brake controller.
- Do not use the magnetic contactor as the run/stop switch of the inverter.

AC reactor for power improvement:

- When inverters below 200V/400V 15KW are supplied with high capacity (above 600KVA) power source or an AC reactor can be connected to improve the power performance.

Input noise filter:

- A filter must be installed when there are inductive load around the inverter

Inverter:

- Input power terminals L1, L2, and L3 can be used in any sequence regardless of phases.
- Output terminals T1, T2, and T3 are connected to U, V, and W terminals of the motor. If the motor is reversed while the inverter is forward, just swap any two terminals of T1, T2, and T3.
- To avoid damaging the inverter, do not connect the input terminals T1, T2, and T3 to AC power.
- Connect the ground terminal properly. 200 V series: class 3 grounding, <math><100\Omega</math>; 400 V series : <math><10\Omega</math>.

Make external connections according to the following instruction. Check connections after wiring to make sure all connections are correct. (Do not use the control circuit buzzer to check connections)

- The inverter uses dedicated power line A general noise filter may not provide rightful results



- Add a noise filter or separation transformer whenter shares the power line with other machines.
- the inverter shares the power line with other machines.

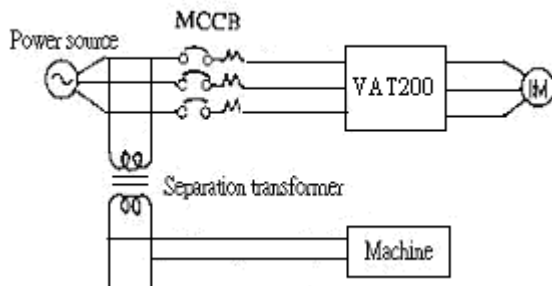
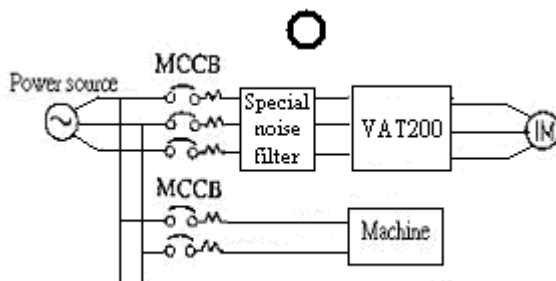

(A) Main circuit's wiring must separate from other high voltage or high current power line to avoid noise interference. Refer to the figures below:

- A noise filter in the output of the main circuit can suppress conductive noise. To prevent radiative noise, the wires should be put in a metal pipe and distance from signal lines of other control machines for more than 30 cm.

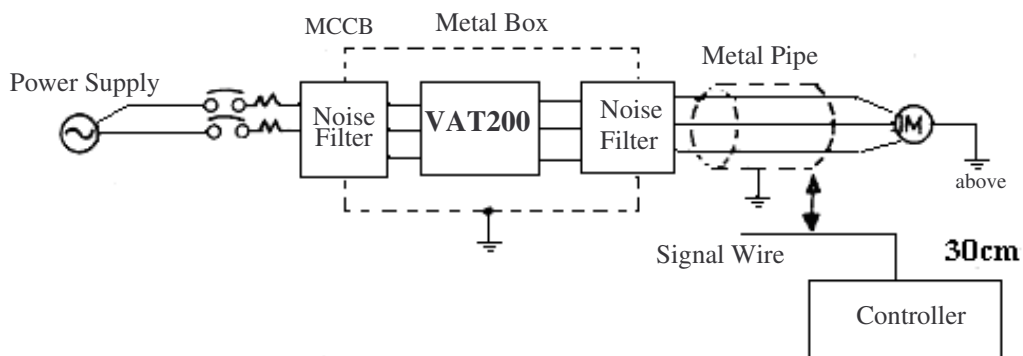

- When the connection between the inverter and the motor is too long, consider the voltage drop of the circuit. Phase-to-phase voltage drop (V) = $\sqrt{3} \times \text{resistance of wire } (\Omega/\text{km}) \times \text{length of line (m)} \times \text{current} \times 10^{-3}$. And the number of carriers must be adjusted based on the length of the line.

The length of the line between the inverter and the motor	Below 25m	Below 50m	Below 100m	Below 100m
Number of carriers allowed	Below 16KHz	Below 12KHz	Below 8KHz	Below 5KHz
Settings of 3-22parameter	16	12	8	5

(B) The wiring of the control circuit must be separated and routed away from the main circuit control line or other high voltage or current power lines to avoid noise interference

- To avoid error actions caused by noise interference, shield the control circuit wiring with a twisted wire, and connect the shielded wire to a ground terminal. Refer to the figure below.

The wiring distance should not exceed 50 m.

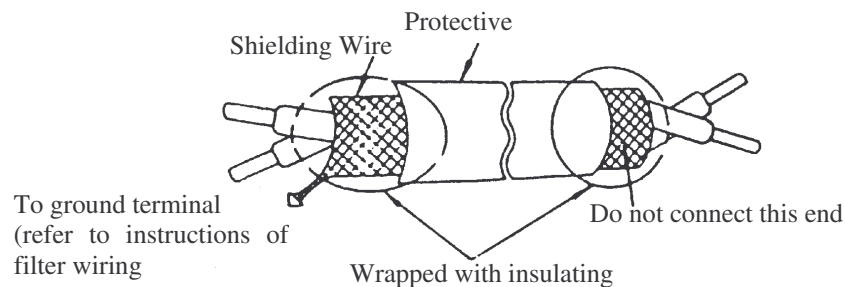

(C) Ground the ground terminal of the inverter properly. For 200V class ground 100Ω or less; for 400V class ground 10Ω or less.

- Ground wiring is based on the electrical equipment technical basis (AWG). The shorter, the better.
- Do not share the ground of the inverter to other high current loads (welding machine, high power motor). Connect the terminals to ground respectively.
- Do not make a loop when several inverters share a common ground point.

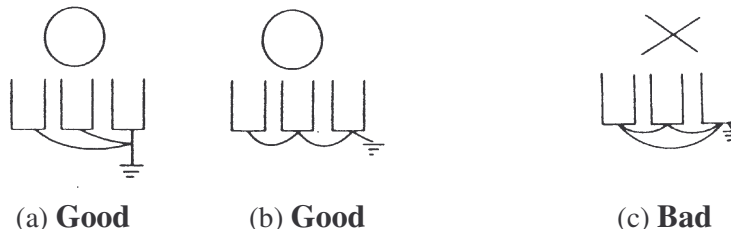

(D) To ensure maximum safety, use proper wire gauges (AWG) for the main power circuit and control circuit according to relative regulations.

(E) After wiring, check that the wiring is correct, wires are intact, and terminal screws are secured.

3.4 Specifications

3.4.1 Products Individual Specifications

Single phase, 200-240V model

Model: U201N □□□□	00K4	00K7	01K5	02K2
Horsepower(HP)	0.5	1	2	3
Suitable Motor Capacity(KW)	0.4	0.75	1.5	2.2
Rated Output Current(A)	3.1	4.5	7.5	10.5
Rated Capacity(KVA)	1.2	1.7	2.9	4.0
Max. Input Voltage	Single Phase: 200~240V +10% -15% , 50/60Hz ± 5%			
Max. Output Voltage	Three Phases: 200~240V			
Input Current(A)	8.5	12	16	23.9
Net Weight(KG)	1.2(1.3)	1.2(1.3)	1.5(1.8)	1.9(2.3)
Allowable momentary power loss time (second)	1.0	1.0	2.0	2.0

Three phases, 200 – 240V model

Model: U203N □□□□	00K4	00K7	01K5	02K2	04K0	05K5	07K5
Horsepower(HP)	0.5	1	2	3	5	7.5	10
Suitable Motor Capacity(KW)	0.4	0.75	1.5	2.2	3.7	5.5	7.5
Rated Output Current(A)	3.1	4.5	7.5	10.5	17.5	26	35
Rated Capacity(KVA)	1.2	1.7	2.9	4.0	6.7	9.9	13.3
Max. Input Voltage	Three Voltage: 200~240V +10% -15% , 50/60Hz ± 5%						
Max. Output Voltage	Three Phase Voltage: 200~240V						
Input Current(A)	4.5	6.5	11	12.5	20.5	33	42
Net Weight(KG)	1.2	1.2	1.2	1.75	1.9	5.6	5.6
Allowable momentary power loss time (second)	1.0	1.0	2.0	2.0	2.0	2.0	2.0

Three phases, 380 – 480V model

Model: U203X □□□□	00K7	01K5	02K2	04K0	05K5	07K5	11K0	15K0	18K5	22K0	30K0	37K0	45K0	55K0
Horsepower(HP)	1	2	3	5	7.5	10	15	20	25	30	40	50	60	75
Suitable Motor Capacity(KW)	0.75	1.5	2.2	3.7	5.5	7.5	11	15	18.5	22	30	37	45	55
Rated Output Current(A)	2.3	3.8	5.2	8.8	13.0	17.5	25	32	40	48	64	80	96	128
Rated Capacity(KVA)	1.7	2.9	4.0	6.7	9.9	13.3	19.1	27.4	34	41	54	68	82	110
Max. Input Voltage	Three Voltage: 380~480V +10% -15% , 50/60Hz ± 5%													
Max. Output Voltage	Three Phase Voltage: 380~480V													
Input Current(A)	4.2	5.6	7.3	11.6	17	23	31	38	48	56	75	92	112	142
Net Weight(KG)	1.2 (1.3)	1.2 (1.3)	1.8 (2.2)	1.8 (2.2)	5.6 (6.6)	5.6 (6.6)	5.6 (6.6)	15	15	15	33	33	50	50
Allowable momentary power loss time (second)	1.0	1.0	2.0	2.0	2.0	2.0	2.0	2.0	2.0	2.0	2.0	2.0	2.0	2.0

3.4.2 General Specifications

Item	VAT200 TYPE	
Control Mode	V/F or Current Vector Control	
Frequency Control	Range	0.1~650.0 Hz
	Start control torque	150%/1Hz (Current Vector)
	Speed control range	1:50 (Current Vector)
	Speed Control Precision	±0.5% (Current Vector)
	Setting resolution	Digital : 0.01Hz(Note *1) ; Analog: 0.06Hz/ 60Hz(10bits)
	Keypad setting	Set directly with ▲ ▼ keys or the VR on the keypad
	Display Function	Four digital LED (or 2×16 LCD) and status indicator; display frequency/ speed/ line speed/ DC voltage/ Output voltage/ Current/ Rotation direction/ Inverter parameter/ Trouble Log/ Program Version
	External signal setting	1. External variable resistor/ 0-10V/ 0-20mA/ 10-0V/ 20-0mA 2. Performs up/down controls, speed control or automatic procedure control with multifunctional contacts on the terminal block (TM2)
	Frequency Limit Function	Respectively setting upper/lower frequency limits and three-stage prohibited frequencies
	Carrier frequency	2 ~ 16 kHz
V/F pattern	18fixable patterns, 1programable curve	
Acc/Dec control	Two-stage Acc/Dec time (0.1 – 3,600 seconds) and two-stage S curves (refer to descriptions on 3-05)	
Multifunctional analog output	6 functions (refer to description on 8-00/8-01)	
Multifunctional input	30 functions (refer to description on 5-00~5-06)	
Multifunctional output	16 functions (refer to description on 8-02~8-03)	
Digital Input Signal	NPN (SINK) / PNP (SOURCE) toggle	
Other Function	Momentary Power Loss Restart, Speed Search, Overload Detection, 8 preset speeds(PLC use 16 preset speeds). Acc/Dec Switch (2 Stages), S Curves, 3-wire Control, PID control, torque boost, Slip Compensation, Frequency Upper/ Lower Limit, Auto energy saving, Modbus slave and PC/PDA Link, Auto Restart, Built-in Simple PLC Function.	

Item	VAT200 TYPE	
Communication Control	1. Control by RS232 or RS485 2. One to one or One to more (RS485 ONLY) control. 3. BAUD RATE/STOP BIT/PARITY/bit can be set	
Braking Torque	About 20% , the model built-in braking transistor and connected braking resistor is 100%	
Operation temperature	-10 ~ 50°C (note 2)	
Storage temperature	-20 ~ 60°C	
Humidity	0 – 95% Relative Humidity(Non-condense)	
Vibration Sustention	1G (9.8m/s ²)	
EMC	Comply with requirement EN 61800-3 (with optional Filter).	
LVD	Comply with requirement EN 50178	
Enclosure	IP20 (NEMA 1 by external box attached)	
Safety Level	UL 508C	
Protective Functions	Overload protection	The relays to protect the motor (the curve can be set) and the inverter (150 % / 1min)
	FUSE protection	The motor stops after FUSE melt
	Over Voltage	200V class : DC Voltage > 410V 400V class : DC Voltage > 820V
	Under Voltage	200V class : DC Voltage < 190V 400V class : DC Voltage < 380V
	Momentary Power Loss Restart	Stop for more than 15ms-power-loss can be restarted with spin start after momentary power loss in Max 2 sec.15ms
	Stall Prevention	Stall prevention for Acceleration/ Deceleration/ Operation.
	Short-circuit output terminal	Electronic Circuit Protection
	Grounding Fault	Electronic Circuit Protection
	Other Function	Protection for overheating of heat sink, over torque detection, error contact control, reverse restriction, restrictions for direct start after power up and error recovery, parameter lock up.

※Note 1 : The setting resolution of above 100Hz is 0.1Hz when controlled with operation keypad, and 0.01 Hz when controlled using computer(PC) or programmable controller(PLC).

※Note 2 : -10 ~ 50°C in distributor (without dustproof cover),
-10 ~ 40°C outside distributor (with dustproof cover).

3.5 Wiring diagram VAT200 series inverter

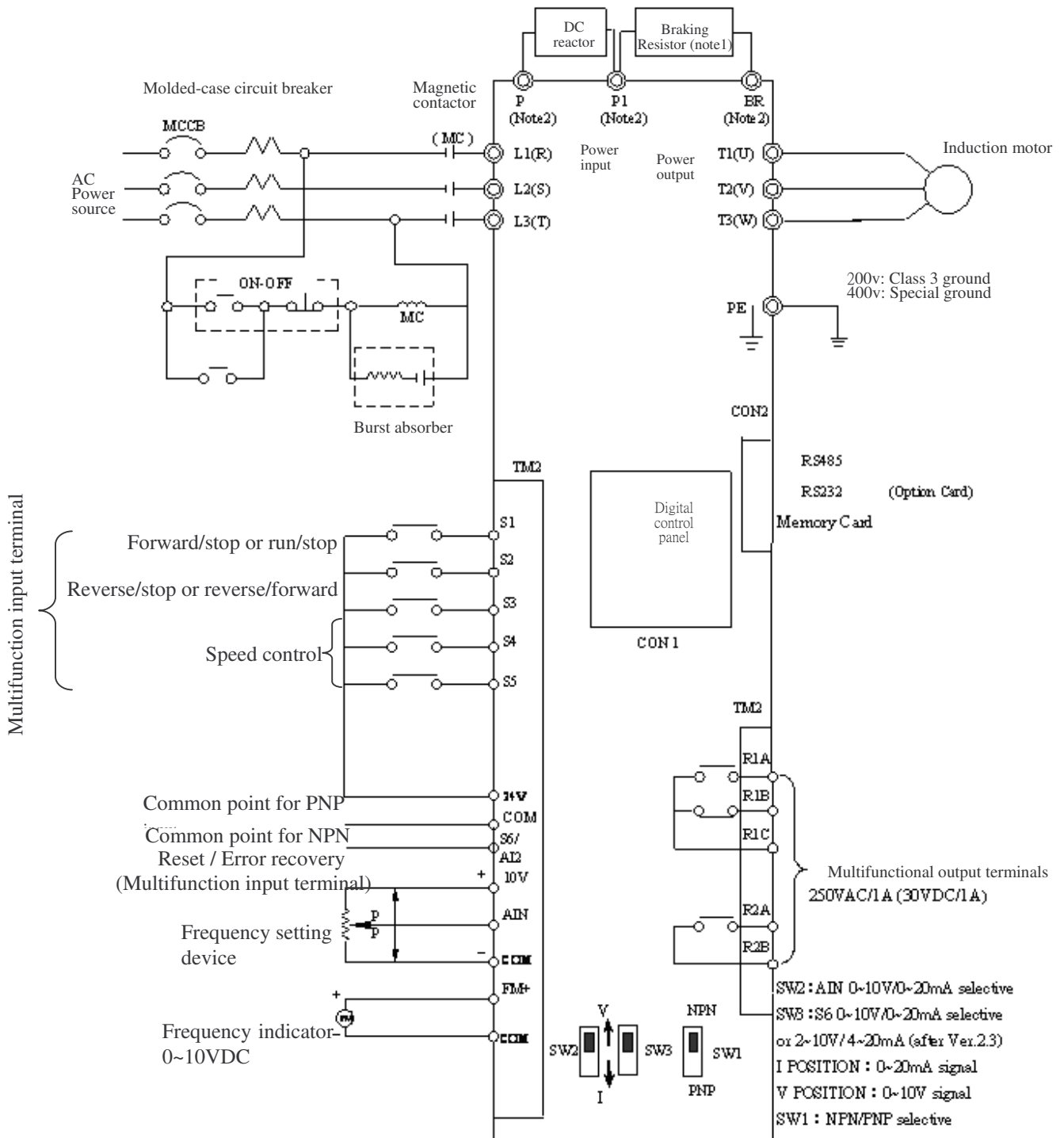

※Note 1 : Please refer to description of main circuit terminals (P1, BR) and specification of braking resistor for value selection.

※Note 2 : Above scheme refers for 220V:0.4~7.5KW and 440V:0.75~11KW only

3.6 Description of terminals of troubleshooting inverter

Descriptions of main circuit terminals

Symbol	Description	
R / L1 (L)	Main power input Single-phase: L/N Three-phase: L1/L2/L3	
S / L2		
T / L3 (N)		
P1	Braking resistor or connecting terminal: Used in cases where the inverter frequently disconnects due to large load inertia or short deceleration time (refer to specifications of braking resistor)	For 220V:0.5~10HP, 440V:1~15HP
BR		
P1、 P	DC reactor connecting terminals	
B1/P	<ul style="list-style-type: none"> ● B1/P-\ominus : DC power supply input B1/P-B2 : External braking resistor For 440V : 15KW 	-
B2		
\ominus		
\oplus	-	<ul style="list-style-type: none"> ● \oplus-\ominus : DC power supply input or External braking unit. Check Chapter 6.3 For 440V : 18.5~55KW
U / T1	Inverter outputs	
V / T2		
W / T3		

Descriptions of VAT200 control circuit terminals

Symbol	Description	
R2A	Multifunctional terminal – Normal open	Contact rated capacity: (250VAC/1A or 30VDC/1A) Contact using description:(refer to 8-02, 8-03)
R2B		
R1C	Common contact	
R1B	Normal close contact	
R1A	Normal open contact	
10V	Frequency knob (VR) power source terminal (pin 3)	
AIN	Analog frequency signal input terminal or multifunction input terminals S7 (H level:>8V, L level:<2V, PNP only) (refer to 5-06 description)	
24V	Common contact for S1~S5 (S6, S7) in PNP (Source) input. Short-circuit pin 2 and pin 3 (refer to VAT200 wiring diagram) of SW1 when used PNP input	
COM	Common contact and analog input /output signal for S1~S5 in NPN (Sink) input. Short-circuit pin 2 and pin 3 (refer to VAT200 wiring diagram) of SW1 when used NPN input	
FM+	The positive analog output for multifunction (refer to 8-00 description), the signal for output terminal is 0-10VDC (below 2mA).	

• 440V : 15KW

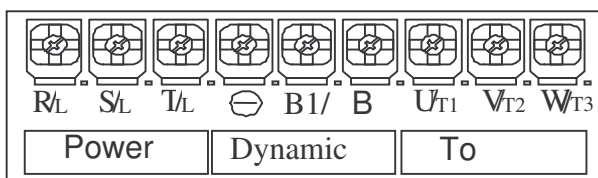



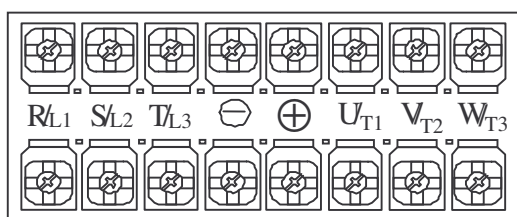

• 440V : 18.5~55KW



Symbol	Function Description
S1	Multifunction input terminals(refer to 5-00 ~ 5-04 description) (S5 = Encoder input terminal, the Encoder voltage range: 19.2V~24.7V)
S2	
S3	
S4	
S5	
S6	Multifunction input terminals (Digital terminal H level:>8V, L level:<2V, PNP only) or analog input terminal AI2(0~10Vdc/4~20mA)(refer to 5-05 description)

Descriptions of SW function

SW2/SW3	Type of external signal	Remarks
	0~10VDC analog signal	External control is available as 1-06=0002
	0~20mA analog signal	

SW1	Type of external signal	Remarks
	NPN (SINK) input	
	PNP (SOURCE) input	Factory default

3.7 Outline Dimensions

(1) Frame1 : Single phase models U201__ : N00K4, N00K7.

Three phase models U203__ : N00K4, N00K7, N01K5, X00K7, X01K5.

(2) Frame2 : Single phase models U201__ : N01K5, N02K2.

Three phase models U203__ : N02K2, N04K0, X02K2, X04K0.

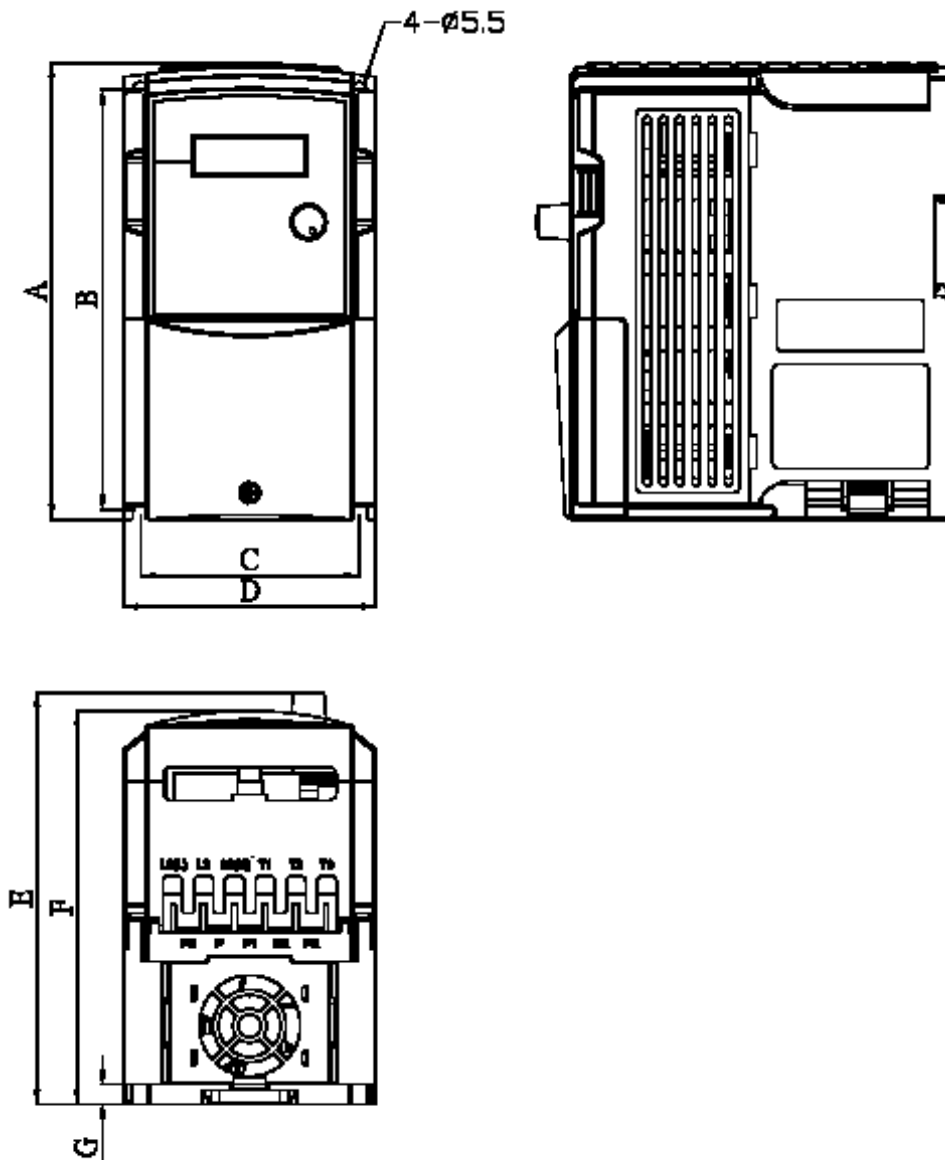

Unit : mm/inch

MODEL \ LENGTH		A	B	C	D
Frame 1		163/6.42	150/5.9	78/3.07	90/3.54
Frame 2		187.1/7.36	170.5/6.71	114.6/4.51	128/5.04
MODEL \ LENGTH		E	F	G	
Frame 1		147/5.79	141/5.55	7/0.28	
Frame 2		148/5.83	142.1/5.59	7/0.28	

(3) Frame3 : Three phase models U203__: N05K5, N07K5, X05K5, X07K5, X11K0.

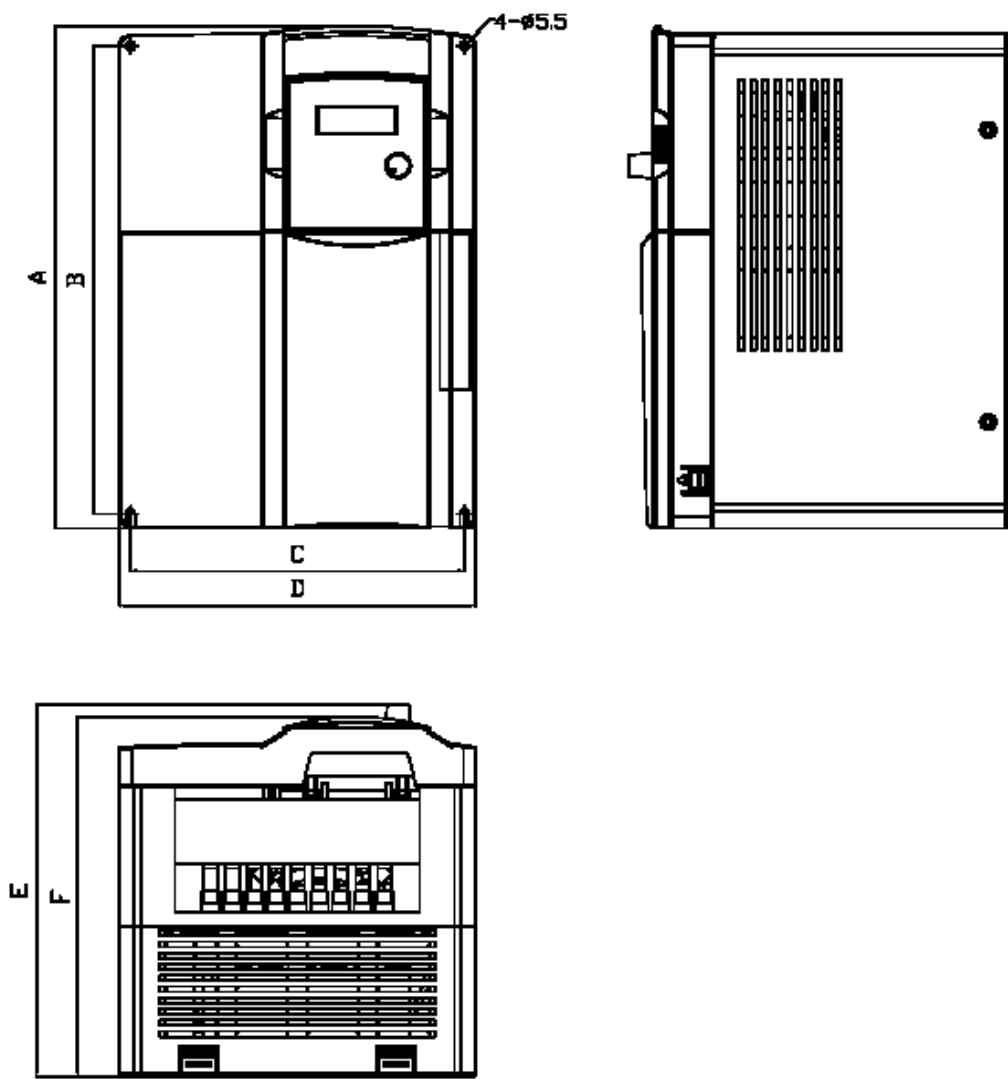

Unit : mm/inch

MODEL	LENGTH					
	A	B	C	D	E	F
Frame 3	260/10.24	244/9.61	173/6.81	186/7.32	195/7.68	188/7.4

(4) Frame4 : Three phase models U203__ : X15K0, X18K5, X22K0

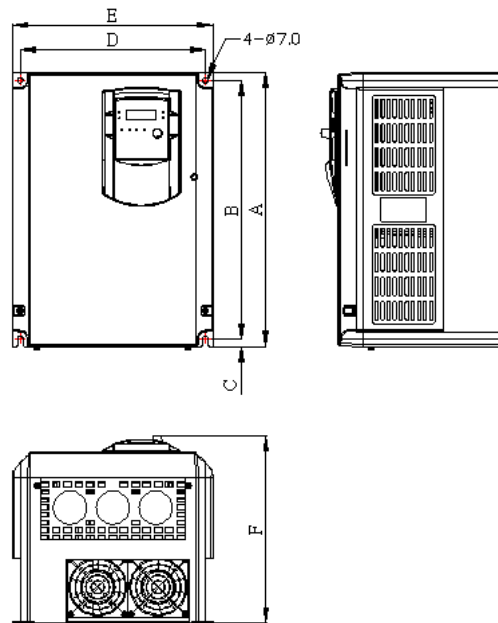

(5) Frame5 : Three phase models U203__ : X30K0, X37K0

(6) Frame6 : Three phase models U203__ : X45K0, X55K0

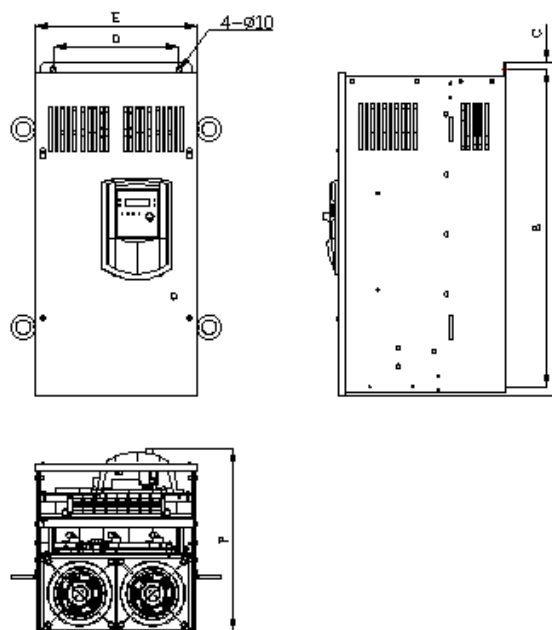

(Open Chassis Type — IP00)

Unit : mm/inch

LENGTH MODEL	A	B	C	D	E	F
Frame4	360/14.2	340/13.4	10/0.4	245/9.6	265/10.4	247.5/9.7
Frame5	553/21.8	530/20.9	10/0.4	210/8.3	269/10.6	303.6/12
Frame6	653/25.7	630/24.8	10/0.4	250/9.8	308/12.1	308.6/15.2

Chapter 4 Software Index

4.1 Keypad Description

4.1.1 Keypad Display and Operation Instruction

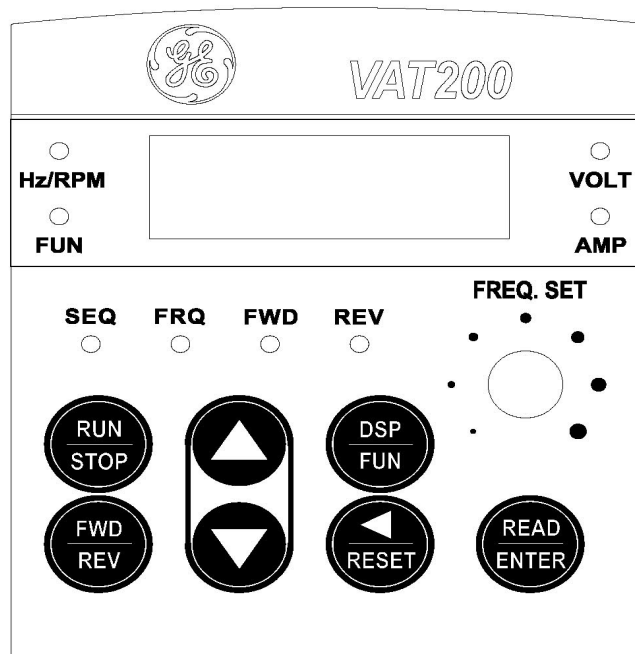

1. SEQ LED : 1_00 = 1/2/3, LED Lit.
2. FRQ LED : 1_06 = 1/2/3/4, LED Lit
3. FWD LED : Forward Direction, LED action(Flash in stop, Keep Lit in operation).
4. REV LED : Reverse Direction, LED action(Flash in stop, Keep Lit in operation).
5. Four action of FUN、Hz/RPM、VOLT、AMP LED and display of four 7-segment display, refer to operation description of the keypad.
6. LCD keypad without FUN, Hz/RPM, VOLT, AMP LED and FREQ.SET knob.

⚠ Caution

To avoid impairing the keypad, do not operate it with screwdriver or sharp and hard tool.

Remote/Local Mode

- Local mode – Operation Command by RUN/STOP key on keypad
 - Frequency Command by ▲▼ key on keypad
- Remote mode – Operating Command by 1-00
 - Frequency Command by 1-06

To Change the Remote/Local mode, you must push **FWD/REV** and **⏪/RESET** key at the same time.

The Remote /Local mode of change can used in STOP mode, it can't used in Run mode.

4.1.2 Operation Instruction of the keypad

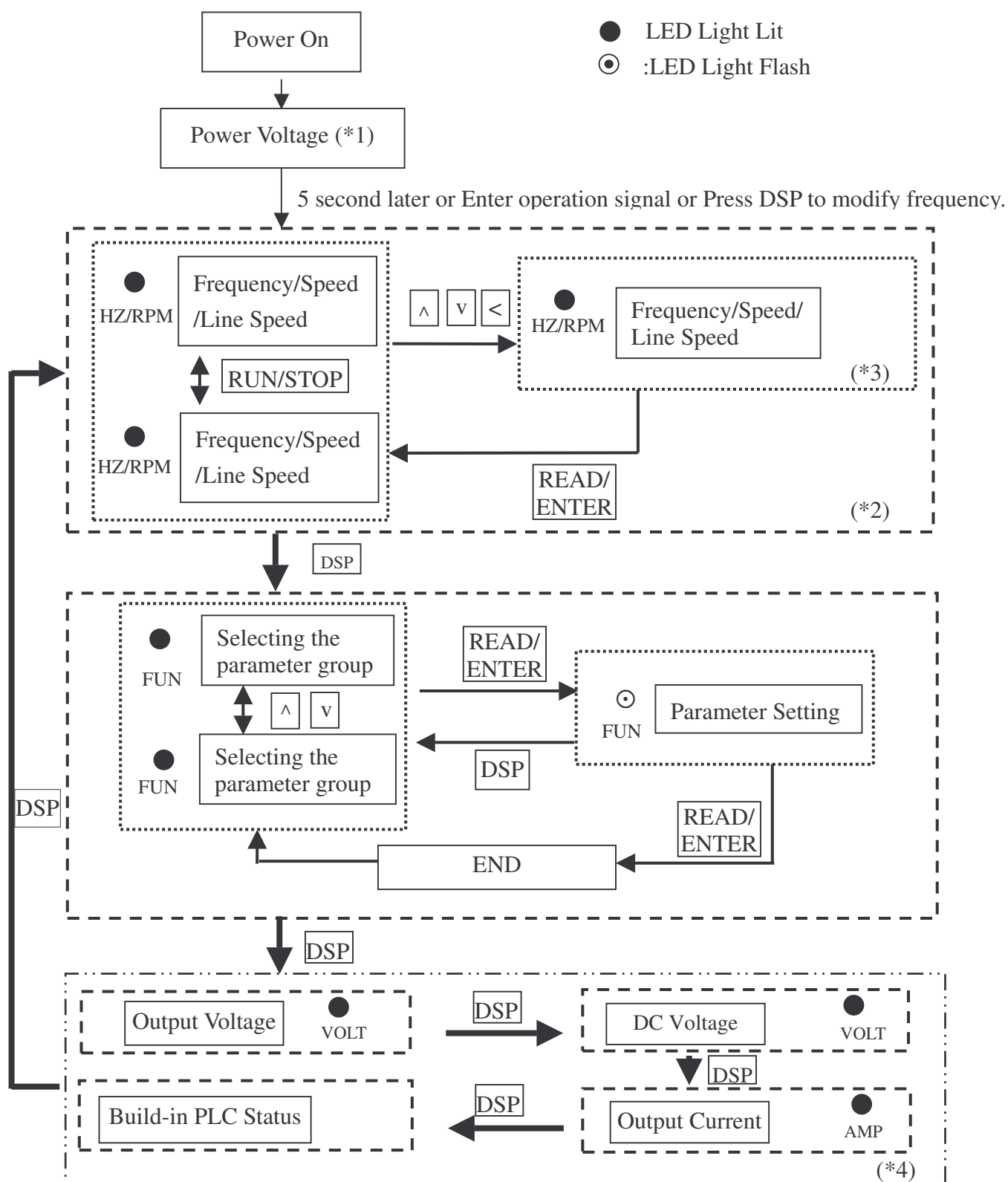

- *1 : The inverter will flash the current setting of 0-07 (power supply voltage) after power up.
- *2 : 4-04, 4-05 determines the displaying of frequency, speed or line speed.
- *3 : It is not necessary to press ENTER key when stopped for modification. Refer to example 1, 2.
- *4 : Whether output current, output voltage, DC voltage, status of built-in PLC is displayed or not is determined by 4-00 ~ 4-03 respectively.

4.1.3 Operation Instruction of the LED keypad

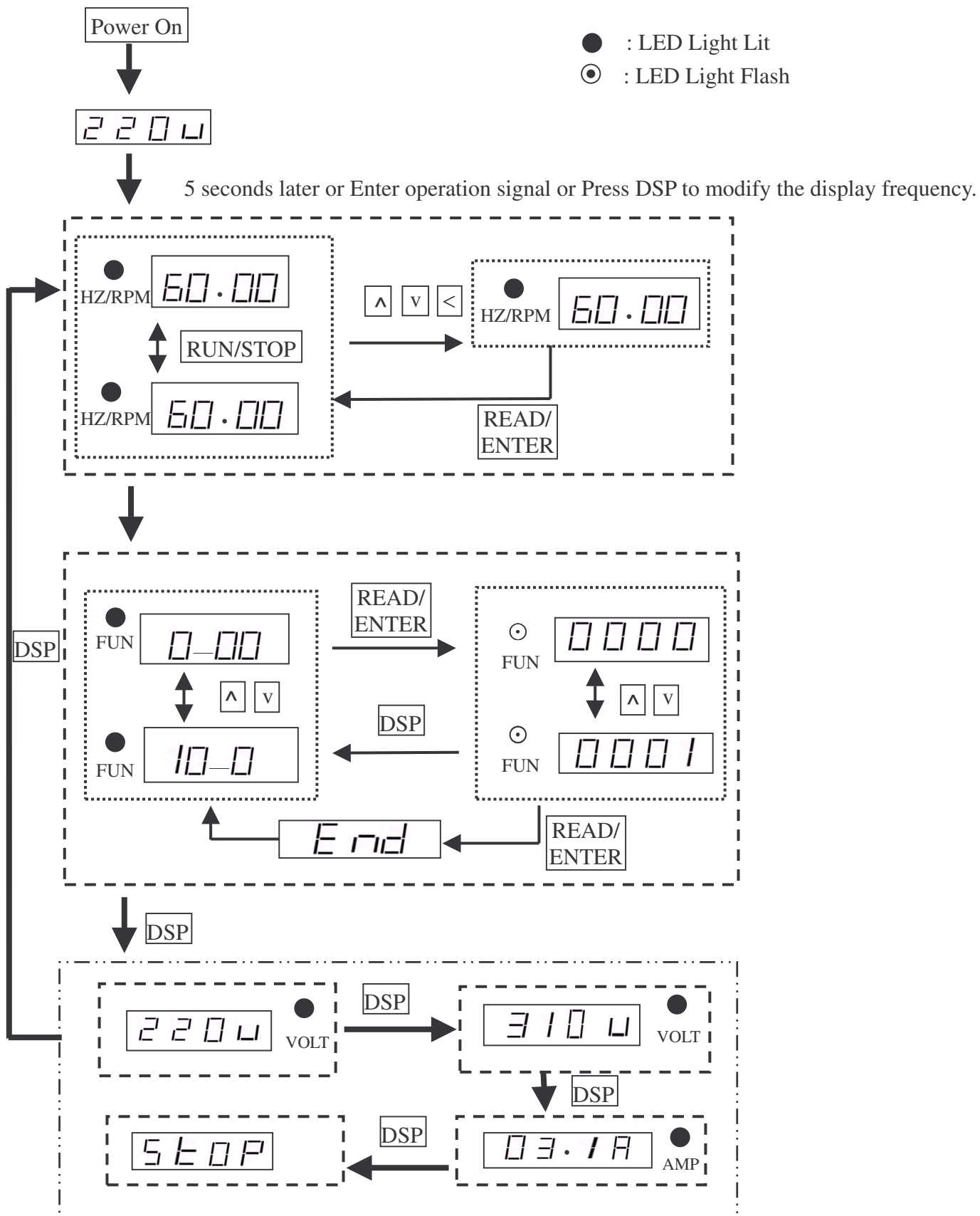

4.1.4 Operation Instruction of the LCD keypad

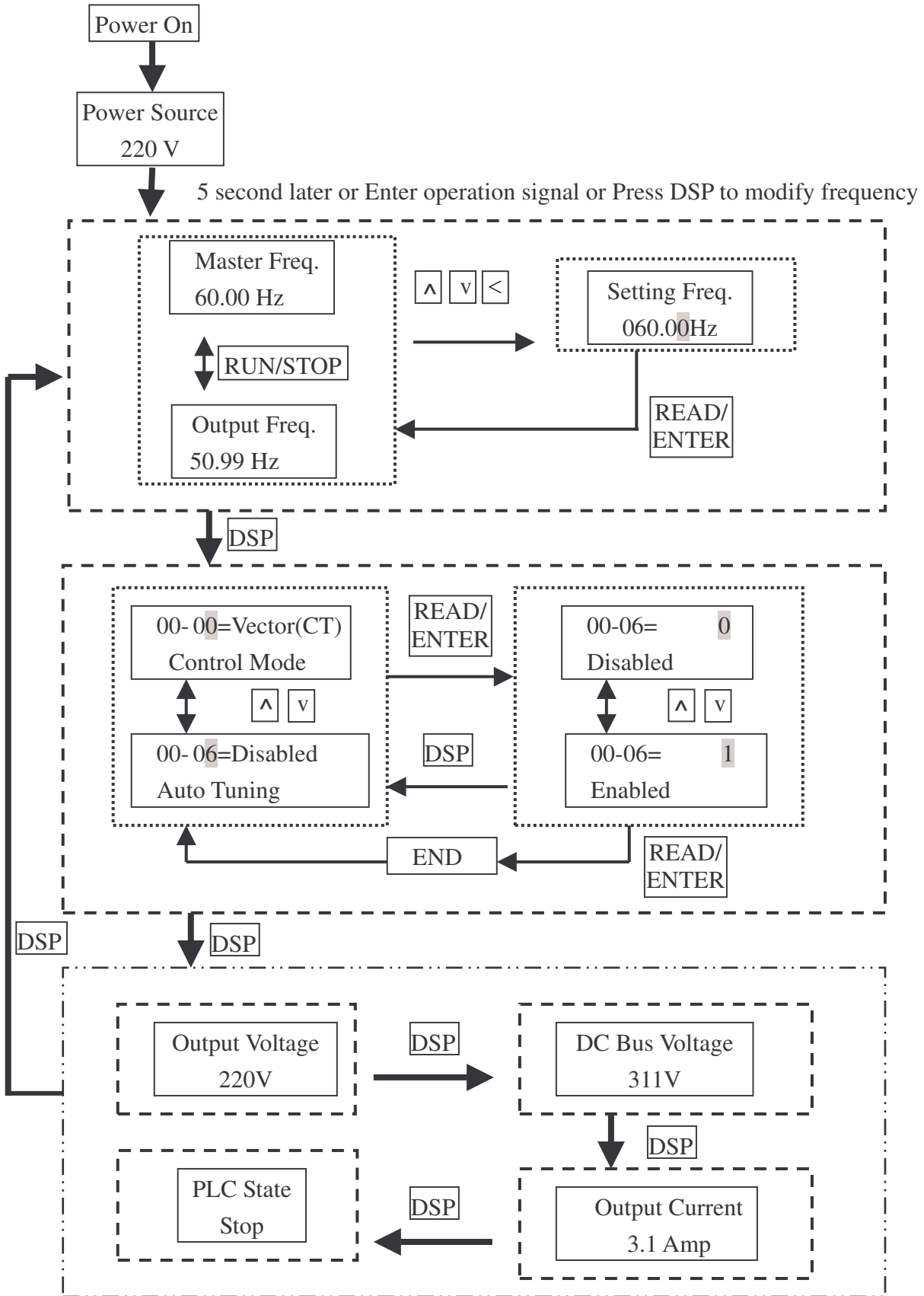

4.1.5 Keypad Operating Example

Example 1. Modify frequency in stopping

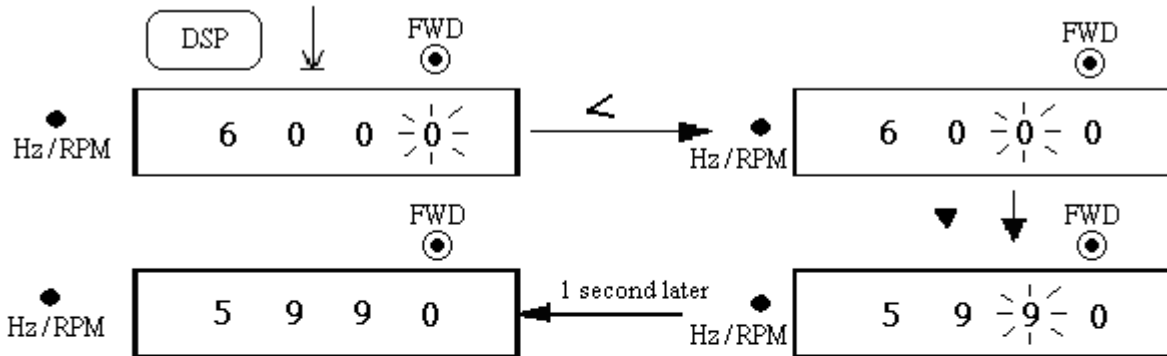

Example 2. Modify frequency in operating

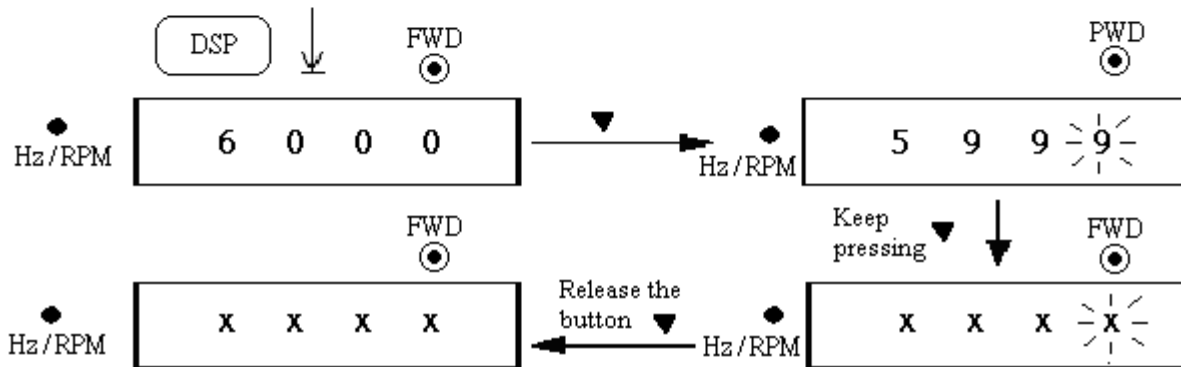

Note : XX.XX shows the present output frequency. The value ranges from 59.58 to 0 Hz, depending on the length of time the key ▼ pressed.

Example 3. Modify frequency in running

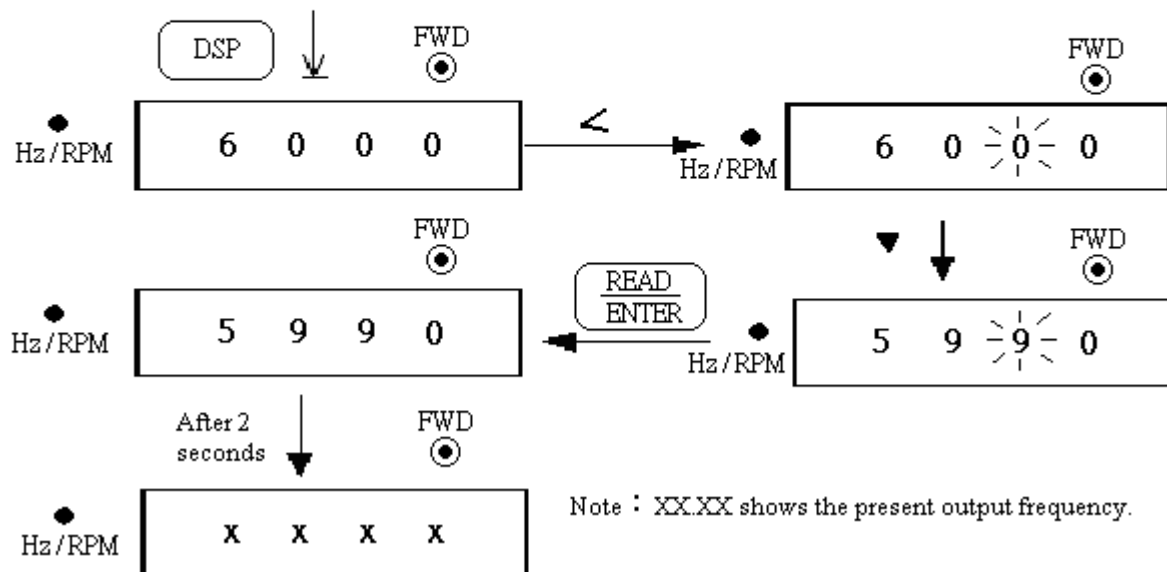

Note : XXX.XX shows the present output frequency.

Example4. Modify the Value of Parameter

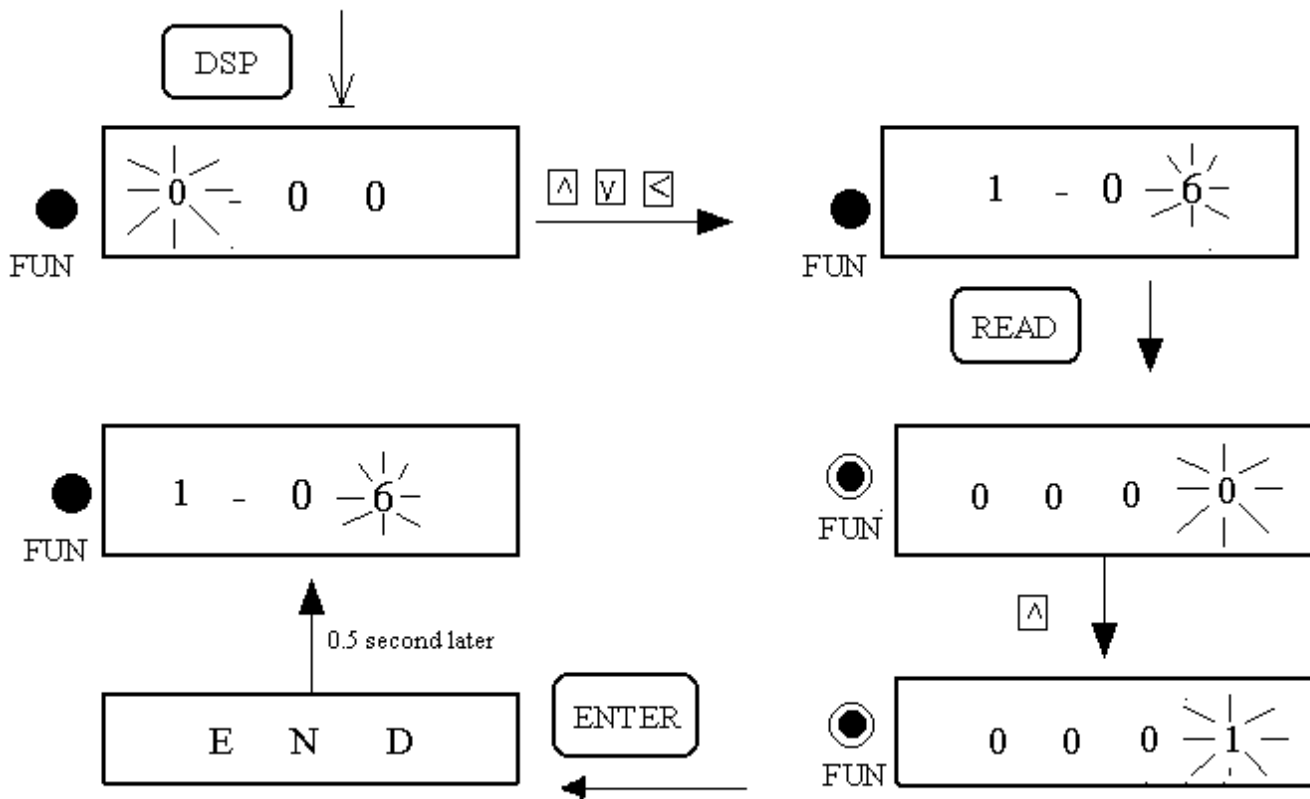

Example 5. Operation Control

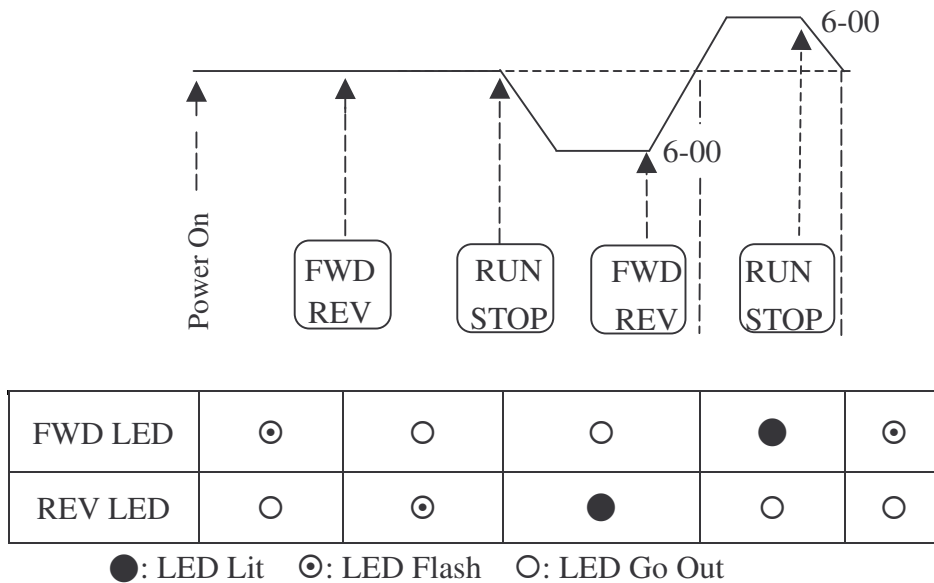

4.2 Control Mode Selection

VAT200 Series inverter has three control modes:

1. General Vector Control Mode
2. VT Vector Control Mode (Special for Blower, Pump).
3. V/F Control Mode.

The user can choose these modes with the digital keypad according to the application characteristics. The factory setting is general vector control mode. Before operation, please set the control mode and the relative parameters of the motor in accordance with the following flow chart. (The Vector control mode only suits for the inverter with same capacity comparing to the motor, or a grade bigger or smaller one).

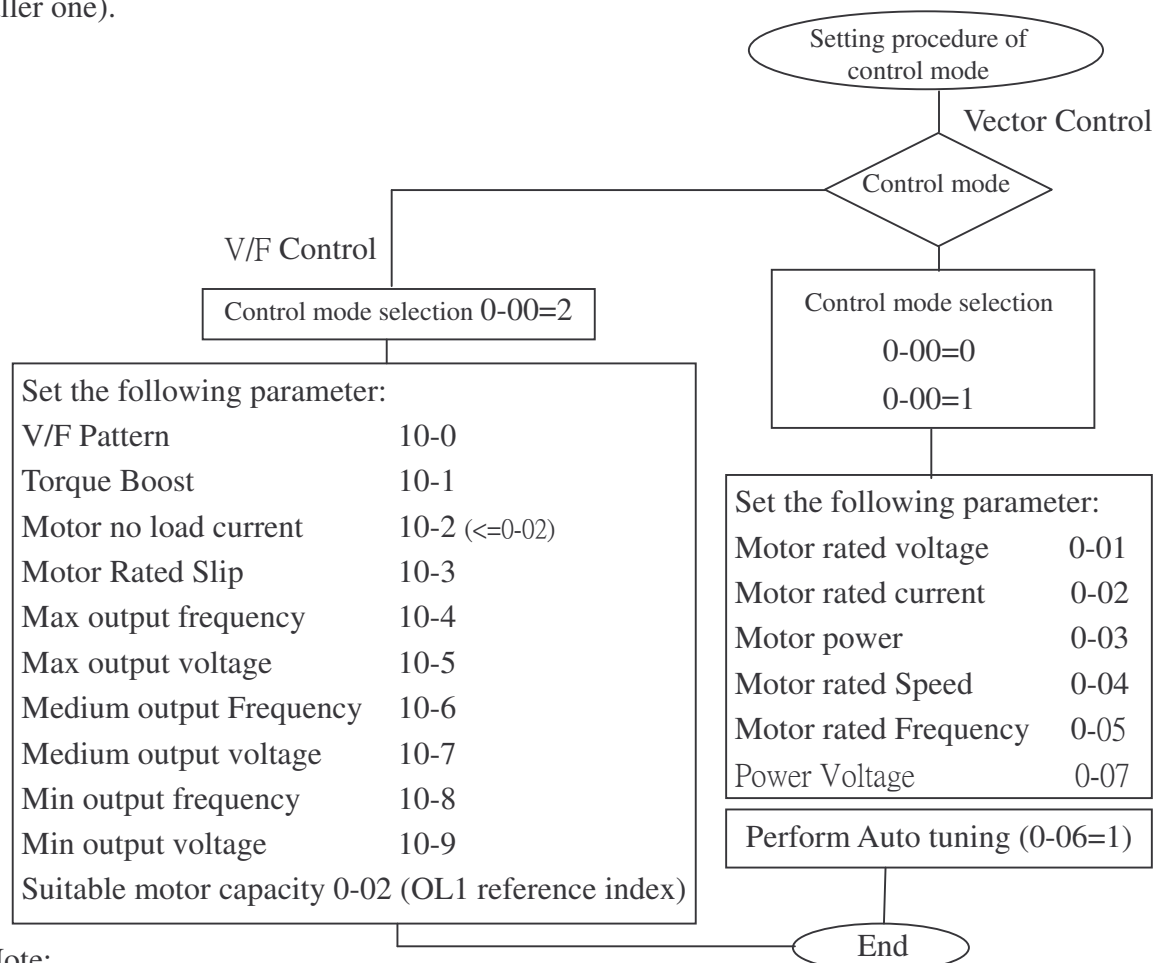

※Note:

1. Use V/F Control Mode:
 - (1) Use one inverter to drive several motors simultaneously
 - (2) Motor's nameplate is unknown or motor's specifications are too special, it will cause Auto-tuning fault.
 - (3) Specification of inverter and motor differ more than 1 class.
2. One inverter drives several motors (Only V/F mode available), set the motor parameter complying with the following rules:
 - (1). As for the current, sum the rated current of all motors.
 - (2). As for others, input correct VF Pattern parameter (10-4~10-9).
3. When the nameplate of the motor is unknown, the inverter will set the internal parameter according to the standard GE motor.
4. When parameter 0-00 does set to 2, the keypad will display 'Err2' in performing Auto tuning.
5. When VF control, 0-01~0-05 max. & min. value by the GE standard motor specification limit(one more & one less level). When VF control, no district.

4.3 VAT200 Programmable Functions List

Parameter Group No.	Description
0-	Drive Operation Mode
1-	Start/Stop and Frequency Control Modes
2-	Manual/Automatic Restart Modes
3-	Operating Parameters
4-	Digital Display Operation Mode
5-	Multifunction Input Terminals (MFIT)
6-	Jog, and Preset (MFIT) Speed Setting on Keypad
7-	Analog Input Signal Operation
8-	Multifunction Output Relays and Output Signal Operation
9-	Drive and Load Protection Modes
10-	Volts/Hz Pattern Operation Mode
11-	PID Operation Mode
12-	PID "Limits" and "Out of Range" Mode
13-	Communication Mode
14-	Motor Auto-Tuning Parameters
15-	Drive Status and Function Reset

0- Drive Operation Mode

Function Code No.	LCD Display	Description	Range/Code	Factory Setting	Remarks
0-00	(Control Mode)	Control Mode	0000: Vector (General Purpose) 0001: Vector (Variable Torque) 0002: Volts/Hz (Refer to Parameter Group 10- Volts/Hz Mode)	0000	*3
0-01	(Motor Rated Volt)	Motor Rated Voltage (Vac)	-----		*3*5
0-02	(Motor Rated Amp)	Motor Rated Current (Amp)	-----		*3*5
0-03	(Motor Rated KW)	Motor Rated Power (kW)	-----		*3*5
0-04	(Motor Rated RPM)	Motor Rated Speed (RPM)X100*7	-----		*3*5
0-05	(Motor Rated Hz)	Motor Rated Frequency (Hz)	-----		*3*5
0-06	(Auto Tuning)	Motor Parameter Auto Tuning	0000: Invalid 0001: Valid	0000	
0-07	(AC Input Volt)	AC Line Input Voltage (Vac)	220V SERIES: 170.0~264.0 440V SERIES: 323.0~528.0		*3
0-08	(Select Language)	Language Selection	0000: English 0001: German 0002: French 0003: Italian 0004: Spanish	0000	Only for LCD keypad

1- Start/Stop and Frequency Control Modes

Function Code No.	LCD Display	Description	Range/Code	Factory Setting	Remarks
1-00	(Run Source)	Run Command Source Selection	0000: Keypad 0001: External Run/Stop Control (See 1-01) 0002: Communication 0003: Built-In PLC	0000	
1-01	(MFIT Run Mode)	Run/Stop-Forward/Reverse Operation Mode with External Terminals	0000: Forward/Stop-Reverse/Stop 0001: Run/Stop-Forward/Reverse 0002: 3-Wire Control Mode-Run/Stop	0000	
1-02	(Reverse Oper)	Prohibition of Reverse operation	0000: Enable Reverse Command 0001: Disable Reverse Command	0000	
1-03	(Keypad Stop)	Keypad Stop Button	0000: Stop Button Enabled 0001: Stop Button Disabled	0000	
1-04	(Starting Method)	Starting Method Selection	0000: Normal Start 0001: Enable Speed Search	0000	
1-05	(Stopping Method)	Stopping Method Selection	0000: Controlled Deceleration-to-Stop with DC Injection Braking (Rapid Stop) 0001: Free run Stop		

1-06	(Frequency Source)	Frequency Command Source Selection	0000: Keypad 0001: Potentiometer on Keypad 0002: External Analog Signal Input or Remote Potentiometer 0003: Up/Down Frequency Control Using MFIT (S1 - S6) 0004: Communication setting frequency 0005: Inpulse (S5) setting frequency (ver2.3)	0000	
1-07	(Keypad Up/Down)	Keypad Operation with Up/Down Keys in Run Mode	0000: 'Enter' must be pressed after frequency change with Up/Down Keys on keypad. 0001: Frequency will be changed directly when Up/Down Keys are Pressed	0000	

2- Manual/Automatic Restart Modes

Function Code No.	LCD Display	Description	Range/Code	Factory Setting	Remarks
2-00	(PwrL Selection)	Momentary Power Loss and Restart	0000: Momentary power loss and restart disable 0001: Momentary power loss and restart enable 0002: Momentary power loss and restart enable while CPU is operating. (According to the capacity of DC power)	0000	
2-01	(PwrL Ridethru T)	Momentary Power Loss Ride-Thru Time (Seconds)	0.0 - 2.0	0.5	
2-02	(Delay of Restart)	Auto Restart Delay Time (Seconds)	0.0 - 800.0	0.0	
2-03	(Num of Restart)	Number of Auto Restart Attempts	0 - 10	0	
2-04	(Auto Restart)	Auto Restart Method	0000: Enable Speed Search 0001: Normal Start	0000	
2-05	(Direct Start Sel)	Direct Running After Power Up	0000: Enable Direct running after power up 0001: Disable Direct running after power up	0001	
2-06	(Delay-on Timer)	Delay-ON Timer (Seconds)	0.0-300.0	0.0	
2-07	(Reset Mode Sel)	Reset Mode Setting	0000: Enable Reset Only when Run Command is Off 0001: Enable Reset when Run Command is On or Off	0000	
2-08	(KEB_Decel_Time)	Kinetic Energy Back-up Deceleration Time	0.0:Disable 0.1~25.0: KEB Deceleration Time	0.0	

3- Operating Parameters

Function Code No.	LCD Display	Description	Range/Code	Factory Setting	Remarks
3-00	(Freq Upper Limit)	Frequency Upper Limit (Hz)	0.01 - 650.00	50.00 / 60.00	*4
3-01	(Freq Lower Limit)	Frequency Lower Limit (Hz)	0.00 - 650.00	0.00	
3-02	(Accel Time 1)	Acceleration Time # 1 (Seconds)	0.1 - 3600.0	10.0	*1
3-03	(Decel Time 1)	Deceleration Time # 1 (Seconds)	0.1 - 3600.0	10.0	*1
3-04	(S-Curve 1)	S-Curve Acc/Dec # 1 (Seconds)	0.0 - 4.0	0.2	
3-05	(S-Curve 2)	S-Curve Acc/Dec # 2(Seconds)	0.0 - 4.0	0.2	
3-06	(Accel Time 2)	Acceleration Time # 2 (MFIT) (Seconds)	0.1 - 3600.0	10.0	*1
3-07	(Decel Time 2)	Deceleration Time # 2 (MFIT) (Seconds)	0.1 - 3600.0	10.0	*1
3-08	(Jog Acc Time)	Jog Acceleration Time (MFIT) (Seconds)	0.1 - 25.5	0.5	*1
3-09	(Jog Dec Time)	Jog Deceleration Time (MFIT) (Seconds)	0.1 - 25.5	0.5	*1
3-10	(DCInj Start Freq)	DC Injection Brake Start Frequency (Hz)	0.1 - 10.0	1.5	
3-11	(DCInj Level)	DC Injection Brake Level (%)	0.0 - 20.0	5.0	*7
3-12	(DCInj Time)	DC Injection Brake Time (Seconds)	0.0 - 25.5	0.5	
3-13	(Skip Freq 1)	Skip Frequency # 1 (Hz)	0.00 - 650.00	0.0	*1
3-14	(Skip Freq 2)	Skip Frequency # 2 (Hz)	0.00 - 650.00	0.0	*1
3-15	(Skip Freq 3)	Skip Frequency # 3 (Hz)	0.00 - 650.00	0.0	*1
3-16	(Skip Bandwidth)	Skip Frequency Bandwidth(± Hz)	0.00 - 30.00	0.0	*1
3-17	(Parameter Lock)	Parameter Lock	0000: Enable all Functions 0001: 6-00 - 6-08 cannot be changed 0002: All Functions Except 6-00 - 6-08 cannot be changed 0003: Disable All Function	0000	
3-18	(ROM Pack Operate)	Copy Unit	0000: Disable 0001: Inverter to Copy Unit 0002: Copy Unit to Inverter 0003: Verify	0000	
3-19	(Fan Control)	Fan Control	0000: Auto (Depend on temp.) 0001: Operate while in RUN mode 0002: Always Run 0003: Always Stop	0000	
3-20	(Energy Save Mode)	Energy Saving Mode * ¹	0000: Disabled 0001: Controlled by MFIT at Set Frequency	0000	*6
3-21	(Energy Save Gain)	Energy Saving Gain (%)* ¹	0 - 100	80	*6
3-22	(Carrier Freq)	Carrier Frequency (kHz)	2 - 16	10	

3-23	(Center F of Trav)	Center Frequency (CF) of Traverse Run (%)	5.00 – 100.00	20.00	
3-24	(Amplit of Trav)	Amplitude (A) of Traverse Run (%)	0.1 – 20.0	10.0	
3-25	(Drop of Trav)	Drop (D) of Traverse Run (%)	0.0 – 50.0	0.0	
3-26	(Acc T of Trav)	Acc Time (AT) of Traverse Run (Seconds)	0.5 – 60.0	10.0	
3-27	(Dec T of Trav)	Dec Time (DT) of Traverse Run (Seconds)	0.5 – 60.0	10.0	
3-28	(Rise Deviated)	Rise (X) Deviated Traverse (%)	0.0 – 20.0	10.0	
3-29	(Lower Deviated)	Lower (Y) Deviated Traverse (%)	0.0 – 20.0	10.0	

※ Notes: 1. Energy Saving Mode is available only under Volts/Hz Mode (0-00 = 0002).

4- Digital Display Operation Mode

Function Code No.	LCD Display	Description	Range/Code	Factory Setting	Remarks
4-00	(Motor Curr Disp)	Motor Current Display Selection	0000: Disable Motor Current Display 0001: Enable Motor Current Display	0000	*1
4-01	(Motor Volt Disp)	Motor Voltage Display Selection	0000: Disable Motor Voltage Display 0001: Enable Motor Voltage Display	0000	*1
4-02	(Bus Volt Disp)	DC Bus Voltage Display Selection	0000: Disable Bus Voltage Display 0001: Enable Bus Voltage Display	0000	*1
4-03	(PLC Status Disp)	PLC Status Display Selection	0000: Disable PLC Status Display 0001: Enable PLC Status Display	0000	*1
4-04	(Display Scaling)	Custom Units (Line Speed) Value	0 - 9999	1800	*1
4-05	(Display Units)	Custom Units (Line Speed) Display Mode	0000: Drive Output Frequency is Displayed 0001: Line Speed is Displayed in Integer (xxxx) 0002: Line Speed is Displayed with One Decimal Place (xxx.x) 0003: Line Speed is Displayed with Two Decimal Places (xx.xx) 0004: Line Speed is Displayed with Three Decimal Places (x.xxx)	0000	*1
4-06	(PID Feed Disp)	PID Feedback Display Selection	0000: Disable PID Feedback Display 0001: Enable PID Feedback Display	0000	*1

5- Multifunction Input Terminals (MFIT)

Function Code No.	LCD Display	Description	Range/Code	Factory Setting	Remarks
5-00	(MFIT S1 Sel)	Multifunction Input Term. S1	0000: Forward/Stop Command * ¹ 0001: Reverse/Stop Command * ² 0002: Preset Speed # 1 (6-02) 0003: Preset Speed # 2 (6-03)	0000	
5-01	(MFIT S2 Sel)	Multifunction Input Term. S2	0004: Preset Speed # 3 (6-05) * ³ 0005: Jog 0006: Acc/Dec # 2 0007: Emergency Stop A Contact 0008: Base Block	0001	
5-02	(MFIT S3 Sel)	Multifunction Input Term. S3	0009: Speed Search 0010: Energy Saving 0011: Control Signal Selection 0012: Communication Selection	0002	
5-03	(MFIT S4 Sel)	Multifunction Input Term. S4	0013: Acc/Dec Disabled 0014: Up Command 0015: Down Command 0016: Master/Auxiliary Speed 0017: PID Function Disabled	0003	
5-04	(MFIT S5 Sel)	Multifunction Input Term. S5	0018: Reset 0019: Encoder input terminal (terminal S5) 0020: PID feedback signal A12 (terminal S6)	0004	
5-05	(MFIT S6 Sel)	Multifunction Input Term. S6	0021: AI2 Bias signal 1 input (terminal S6) 0022: AI2 Bias signal 2 input (terminal S6)	0018	
5-06	(MFIT AIN Sel)	Multifunction Input Term. AIN	0023: Analog input (terminal AIN) 0024: PLC Application 0025: Traverse Run 0026: Traverse run upper deviation 0027: traverse run lower deviation 0028: Power Source Detect for KEB Function 0029: Emergency Stop B Contact * ⁷	0023	
5-07	(MFIT Scan Time)	Multifunction Input Term. S1 - S6 Signal Verification Scan Time (mSec X 4)	1 – 100	5	

5-08	(Stop Sel by MFIT)	Stop Mode Using MFIT	0000: When the MFITs are Programmed for Up/Down Frequency Control, the Set Frequency will remain when the Drive stops. And when the Drive stops, Up/Down Function Disabled. 0001: Up/Down is used. The preset frequency is reset to 0 Hz as the inverter stops. 0002: When the MFITs are Programmed for Up/Down Frequency Control, the Set Frequency will remain when the Drive stops. And when the Drive stops, Up/Down Function Enabled. *7	0000	
5-09	(Step Up/Down Fun)	Step of Up/Down Function (Hz)	0.00 – 5.00	0.00	
5-10	(Pulse Inp. Mult.)	Encoder Inpulse Ratio	0.001 – 9.999	1.000	*7
5-11	(Ref.Source2)	Select the source of auxiliary frequency command	0 - 4	0	*7

※Notes: 1. To switch to Run/Stop with Function 1-01 = 0001.

2. To switch to Forward/Reverse with Function 1-01 = 0001.

3. Preset Speed # 3 is obtained by activating Terms. S3 and S4 simultaneously.

6- Jog, and Preset (MFIT) Frequency Setting on Keypad

Function Code No.	LCD Display	Description	Range/Code	Factory Setting	Remarks
6-00	(Keypad Freq)	Keypad Frequency (Hz)	0.00 - 650.00	5.00	*1
6-01	(Jog Freq)	Jog Frequency (Hz)	0.00 - 650.00	2.00	*1
6-02	(Preset Speed #1)	Preset Speed # 1 (Hz)	0.00 - 650.00	5.00	*1
6-03	(Preset Speed #2)	Preset Speed # 2 (Hz)	0.00 - 650.00	10.00	*1
6-04	(Preset Speed #3)	Preset Speed # 3 (Hz)	0.00 - 650.00	20.00	*1
6-05	(Preset Speed #4)	Preset Speed # 4 (Hz)	0.00 - 650.00	30.00	*1
6-06	(Preset Speed #5)	Preset Speed # 5 (Hz)	0.00 - 650.00	40.00	*1
6-07	(Preset Speed #6)	Preset Speed # 6 (Hz)	0.00 - 650.00	50.00	*1
6-08	(Preset Speed #7)	Preset Speed # 7 (Hz)	0.00 - 650.00	60.00	*1

7- Analog Input Signal Operation

Function Code No.	LCD Display	Description	Range/Code	Factory Setting	Remarks
7-00	(AIN Gain)	AIN Gain (%)	0 - 200	100	*1
7-01	(AIN Offset)	AIN Bias (%)	0 - 100	0	*1
7-02	(AIN Bias)	AIN Bias Selection	0000: Positive 0001: Negative	0000	*1
7-03	(AIN Slope)	AIN Slope	0000: Positive 0001: Negative	0000	*1
7-04	(AIN Scan Time)	AIN Signal Verification Scan Time (AIN, AI2) (mSec x 2)	1 - 100	50	
7-05	(AI2 Gain)	AI2 Gain (%) (S6)	0 - 200	100	*1

※ Notes: Group 7 is available when 5-06=0023 (AIN term.=Analog input)

8- Multifunction Output Relays and Output Signal Operation

Function Code No.	LCD Display	Description	Range/Code	Factory Setting	Remarks
8-00	(AO Mode Sel)	Analog Output Voltage Mode (0 - 10 VDC, Term. FM+)	0000: Output Frequency 0001: Frequency Setting 0002: Output Voltage 0003: DC Voltage 0004: Output Current 0005: PID Feedback *7	0000	*1
8-01	(AO Gain)	Analog Output Gain (%)	0 - 200	100	*1
8-02	(Relay R1 Sel)	Output Relay R1 Operation Mode	0000: Run 0001: Frequency Reached (Frequency Command) (Set Frequency \pm 8-05) 0002: Set Frequency (8-04 \pm 8-05) 0003: Frequency Threshold Level (> 8-04) - Frequency Reached 0004: Frequency Threshold Level (< 8-04) - Frequency Reached 0005: Over torque Threshold Level 0006: Fault 0007: Auto Restart	0006	
8-03	(Relay R2 Sel)	Output Relay R2 Operation Mode	0008: Momentary AC Power Loss 0009: Rapid Stop Mode 0010: Coast-to-Stop Mode 0011: Motor Overload Protection 0012: Drive Overload Protection 0013: PID Feedback Signal Loss 0014: PLC Operation 0015: Power On *7	0000	
8-04	(Freq Agree)	Frequency Reached (Hz) (Refer to 8-02: 0001)	0.00 - 650.00	0.00	*1
8-05	(Freq Agree width)	Frequency Reached Bandwidth (\pm Hz)	0.00 - 30.00	2.00	*1

9- Drive and Load Protection Modes

Function Code No.	LCD Display	Description	Range/Code	Factory Setting	Remarks
9-00	(Trip ACC Sel)	Trip Prevention Selection During Acceleration	0000: Enable Trip Prevention During Acceleration 0001: Disable Trip Prevention During Acceleration	0000	
9-01	(Trip ACC Level)	Trip Prevention Level During Acceleration (%)	50 - 300	200	
9-02	(Trip DEC Sel)	Trip Prevention Selection During Deceleration	0000: Enable Trip Prevention During Deceleration 0001: Disable Trip Prevention During Deceleration	0000	
9-03	(Trip DEC Level)	Trip Prevention Level During Deceleration (%)	50 - 300	200	

9-04	(Trip RUN Sel)	Trip Prevention Selection in Run Mode	0000: Enable Trip Prevention in Run Mode 0001: Disable Trip Prevention in Run Mode	0000	
9-05	(Trip Run Level)	Trip Prevention Level In Run Mode (%)	50 - 300	200	
9-06	(Dec Sel Trip RUN)	Trip Prevention Deceleration Time Selection in Run Mode	0000: Trip Prevention Deceleration Time Set by 3-03 0001: Trip Prevention Deceleration Time Set by 9-07	0000	
9-07	(Dec Time Trip RUN)	Deceleration Time In Trip Prevention Mode (Seconds)	0.1 – 3600.0	3.0	
9-08	(Motor OL1 Sel)	Electronic Motor Overload Protection Operation Mode	0000: Enable Electronic Motor Overload Protection 0001: Disable Electronic Motor Overload Protection	0000	
9-09	(Motor Type)	Motor type Selection	0000: Electronic Motor Overload Protection Set for Non-Inverter Duty Motor 0001: Electronic Motor Overload Protection Set for Inverter Duty Motor	0000	
9-10	(Motor OL1 Curve)	Motor Overload Protection Curve Selection	0000: Constant Torque (OL =103 %) (150 % for 1 Minute) 0001: Variable Torque (OL = 113 %) (123 % for 1 Minute)	0000	
9-11	(Motor OL1 Operat)	Operation After Overload Protection is Activated	0000: Coast-to-Stop After Overload Protection is Activated 0001: Drive Will Not Trip when Overload Protection is Activated (OL1)	0000	
9-12	(Torq Det Sel)	Over torque Detection Selection	0000: Disable Over torque Operation 0001: Enable Over torque Operation Only if at Set Frequency 0002: Enable Over torque Operation while the Drive is in Run Mode	0000	
9-13	(Torq Det Operat)	Operation After Over torque Detection is Activated	0000: Drive will Continue to Operate After Over torque is Activated 0001: Coast-to-Stop After Over torque is Activated	0000	
9-14	(Torq Det Level)	Over torque Threshold Level (%)	30 - 200	160	
9-15	(Torq Det Delay)	Over torque Activation Delay Time (Seconds)	0.0 - 25.0	0.1	

10- Volts/Hz Operation Mode

Function Code No.	LCD Display	Description	Range/Code	Factory Setting	Remarks
10-0	(V/F Selection)	Volts/Hz Patterns	0 - 18	0/9	*4*6
10-1	(Torque Boost)	Volts/Hz Curve Modification (Torque Boost) (%)	0 – 30.0	0.0	*1*6
10-2	(Motor noLoad Amp)	Motor No Load Current (Amps AC)	-----		*5*6
10-3	(Motor rated Slip)	Motor Slip Compensation (%)	0.0 – 100.0	0.0	*1*6
10-4	(Max frequency)	Maximum Frequency (Hz)	0.20 - 650.00	50.00/ 60.00	*4*6
10-5	(Max Voltage)	Maximum Frequency Voltage Ratio (%)	0.0 - 100.0	100.0	*6
10-6	(Mid frequency)	Mid Frequency (Hz)	0.10 - 650.00	25.00/ 30.00*7	*4*6
10-7	(Mid Voltage)	Mid Frequency Voltage Ratio (%)	0.0 - 100.0	50.0*7	*6
10-8	(Min frequency)	Minimum Frequency (Hz)	0.10 - 650.00	0.50/ 0.60	*6
10-9	(Min Voltage)	Minimum Frequency Voltage Ratio (%)	0.0 - 100.0	1.0*7	*6

11- PID Operation Mode

Function Code No.	LCD Display	Description	Range/Code	Factory Setting	Remarks
11-0	(PID Mode Sel)	Mode Selection	0000: Disabled 0001: Bias D Control 0002: Feedback D Control 0003: Bias D Reversed Characteristics Control 0004: Feedback D Reversed Characteristics Control 0005: Frequency Command + Bias D Control 0006: Frequency Command + Feedback D Control 0007: Frequency Command + Bias D Reversed Characteristics Control 0008: Frequency Command + Feedback D Reversed Characteristics Control	0000	
11-1	(Feedback Gain)	Feedback Gain (%)	0.00 - 10.00	1.00	*1
11-2	(PID Gain)	Proportional Gain (%)	0.0 - 10.0	1.0	*1
11-3	(PID I Time)	Integration Time (Seconds)	0.0 - 100.0	10.0	*1
11-4	(PID D Time)	Differentiation Time (Seconds)	0.00 - 10.00	0.00	*1
11-5	(PID Offset)	PID Offset	0000: Positive 0001: Negative	0000	*1
11-6	(PID Offset Adj)	PID Offset Adjust (%)	0 - 109	0	*1
11-7	(Output Filter T)	Output Lag Filter Time (Seconds)	0.0 - 2.5	0.0	*1

12- PID "Limits" and "Out of Range" Mode

Function Code No.	LCD Display	Description	Range/Code	Factory Setting	Remarks
12-0	(Fb Los Det Sel)	Feedback Loss Detection Mode	0000: Disabled 0001: Enabled - Drive Continues to Operate After Feedback Loss 0002: Enabled - Drive "STOPS" After Feedback Loss	0000	
12-1	(Fb Los Det Lvl)	Feedback Loss Detection Level (%)	0 - 100	0	
12-2	(Fb Los Det Time)	Feedback Loss Detection Delay Time (Seconds)	0.0 -25.5	1.0	
12-3	(PID I Limit)	Integration Limit Value (%)	0 - 109	100	*1
12-4	(I Time value Sel)	Integration Value Resets to Zero when Feedback Signal Equals the Intended Value	0000: Disabled 0001: 1 Second 0030: 30 Seconds	0000	
12-5	(I Error Margin)	Allowable Integration Error Margin (Units) (1 Unit = 1/8192)	0 - 100	0	
12-6	(PID Comm. Source)	PID Feedback signal	0000: 0~10V or 0~20mA 0001: 2~10V or 4~20mA	0000	*7
12-7	(Sleep Level)	Sleep Function Operation Level	0.00-650.00	0.0	
12-8	(Sleep Delay Time)	Sleep Function Delay Time	0.0-25.5	0.0	

13- Communication Mode

Function Code No.	LCD Display	Description	Range/Code	Factory Setting	Remarks
13-0	(Serial Comm Adr)	Assigned Communication Station Number	1 - 254	1	*2*3
13-1	(Serial Baud Rate)	Baud Rate Setting (bps)	0000: 4800 0001: 9600 0002: 19200 0003: 38400	0003	*2*3
13-2	(Comm Stop Bit)	Stop Bit Selection	0000: 1 Stop Bit 0001: 2 Stop Bits	0000	*2*3
13-3	(Comm Parity Sel)	Parity Selection	0000: Without Parity 0001: With Even Parity 0002: With Odd Parity	0000	*2*3
13-4	(Comm Data Format)	Data Format Selection	0000: 8-Bits Data 0001: 7-Bits Data	0000	*2*3

14- Motor Auto-Tune Parameters

Function Code No.	LCD Display	Description	Range/Code	Factory Setting	Remarks
14-0	(Stator Resistor)	Stator Resistance (Ohms)	-----		*3*5
14-1	(Rotor Resistor)	Rotor Resistance (Ohms)	-----		*3*5
14-2	(Equi Inductance)	Equivalent Inductance (mH)	-----		*3*5
14-3	(Magnet Current)	Magnetizing Current (Amps AC)	-----		*3*5
14-4	(Ferrite Loss)	Ferrite Loss Conductance (gm)	-----		*3*5

15- Drive Status and Function Reset

Function Code No.	LCD Display	Description	Range/Code	Factory Setting	Remarks
15-0	(Drive Model)	Drive Horsepower Code	(See page 4-53)		*3
15-1	(Software Version)	Software Version	-----	-----	*3
15-2	(Fault Log)	Fault Jog (Last 3 Faults)	(See page 4-53)	-----	*3
15-3	(Elapsed Hours)	Accumulated Operation Time (Hours)	0 - 9999	-----	*3
15-4	(Elapsed Hr*10000)	Accumulated Operation Time (Hours X 10000)	0 - 27	-----	*3
15-5	(Elapsed Time Sel)	Accumulated Operation Time Mode	0000: Time Under Power 0001: Run Mode Time Only	0000	*3
15-6	(Reset Parameter)	Reset Drive to Factory Settings	1110: Reset for 50 Hz Motor Operation 1111: Reset for 60 Hz Motor Operation 1112: Reset PLC Program	0000	*4

※Notes: *1 can be modified during operation

*2 cannot be modified during communication

*3 do not change while making factory setting

*4 as parameter related to factory setting

*5 the parameter will be changed by replacing model (see descriptions of the POSTSCRIPT 1)

*6 only available in V/F mode

*7 only for version 2.3 and above.

4.4 Parameter Function Description

Parameter Group 0: Drive Operation Mode

0-00: Control Mode

0000: Vector mode (General Mode)

0001: Vector mode (VT Mode)

0002: V/F mode

To select the most suitable vector control mode or V/F mode according to the load characteristics.

1. Vector (general mode) is inclined to control the general load or rapidly-changed torque load.
2. Vector (VT mode) is suitable for Blower/ Pump and HVAC load. The magnetic current of motor will be variable with the torque, which will reduce the current to save the energy.
3. As V/F mode is selected, please set the parameter group10 comply with the load features.

0-01:Motor Rated Voltage (Vac)

0-02:Motor Rated Current (A)

0-03:Motor Rated Power (kW)

0-04:Motor Rated Speed (RPM)

0-05:Motor Rated Frequency (Hz)

0-06:Motor Parameter Auto Tuning

0000: Disabled

0001: Enabled

It is necessary to input the data on nameplate and auto tuning as long as changing the motor as vector mode is selected.

Auto tuning: firstly input the data to 0-01~0-05 according to the nameplate after power off, then set 0-06=0001and perform auto tuning; the motor will run. It will stop as the inverter finishes auto tuning. The detected internal data will auto be written to parameter group 14.

⚠ Precaution

1. The motor parameter auto tuning is the stationary auto tuning. During motor auto tuning, the motor does not rotate, and the keypad display -AT-.
2. During motor parameter auto tuning, the input signal in control circuit is invalid.
3. Before motor parameter auto tuning, please confirm the stop state of the motor.
4. The motor parameter auto tuning is only available for vector control mode (0-00=0000or 0-00=0001).

0-07 AC Line Input Voltage (Volts AC)

220V series: 170.0~264.0

440V series: 323.0~528.0

To make sure the voltage level of inverter, please input the actual on-site voltage value.

0-08 Language Selection

0000: English

0001: German

0002: French

0003: Italian

0004: Spanish

The function is only available for the products with LCD operation keypad. The operation is not necessary for the one with LED.

Parameter Group 1 - Start/Stop and Frequency Control Modes

1-00 : Run Command Source Selection

0000:Keypad

0001:External terminal control

0002:Communication control

0003:Built-in PLC

- 1.) 1-00=0000 the inverter is controlled by the keypad.
- 2.) 1-00=0001 the inverter is controlled by the external terminals, and the Stop key for emergency does work. (Refer to 1-03 description).
Note: 1-00=0001, please refer to parameter group 2-00, 2-01, 2-02 and 2-03 for detail description to make secure of persons and machines.
- 3.) 1-00=0002 the inverter is communication controlled.
- 4.) 1-00=0003 the inverter is built-in PLC controlled, and 1-06 preset value is invalid.

1-01 : Operation modes for external terminals

0000:Forward/stop-reverse/stop

0001:Run/stop-forward/reverse

0002:3-wire control mode -run/stop

- 1.) When operation command 1-00 = 0001 (external terminal), 1-01 is valid.
- 2.) When operation command 1-00 = 0001 (external terminal control), the stop button for emergency is available. (Refer to 1-03 for detail description).
- 3.) That both forward and reverse commands are ON will be treated as STOP.

1-01 = 0000, Control mode is as below:

(1). Input signal is NPN:

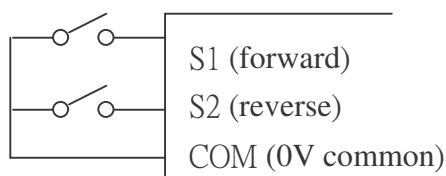

(2). Input signal is PNP:

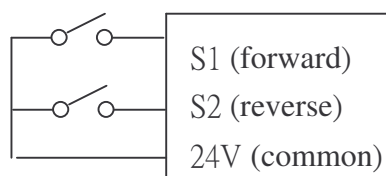

1-01 = 0001, Control mode is as below:

(1). Input signal is NPN:

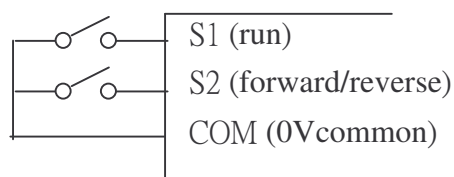

(2). Input signal is PNP:

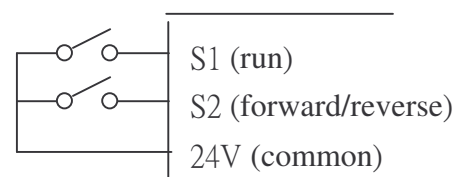

1-01 = 0002, Control mode is as below:

(1). Input signal is NPN:

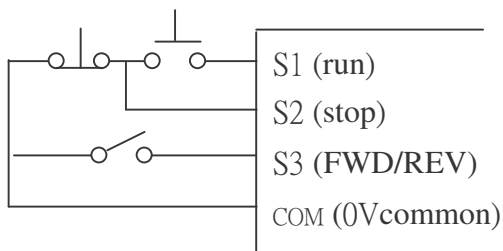

(2). Input signal is PNP:

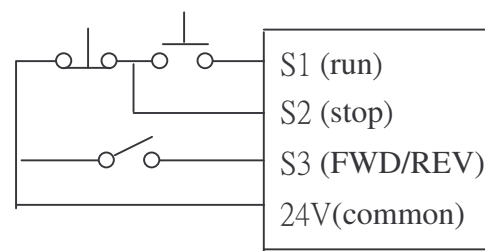

※Note: As 3 wire control mode is selected, the terminal S3 is not controlled by 5-02.

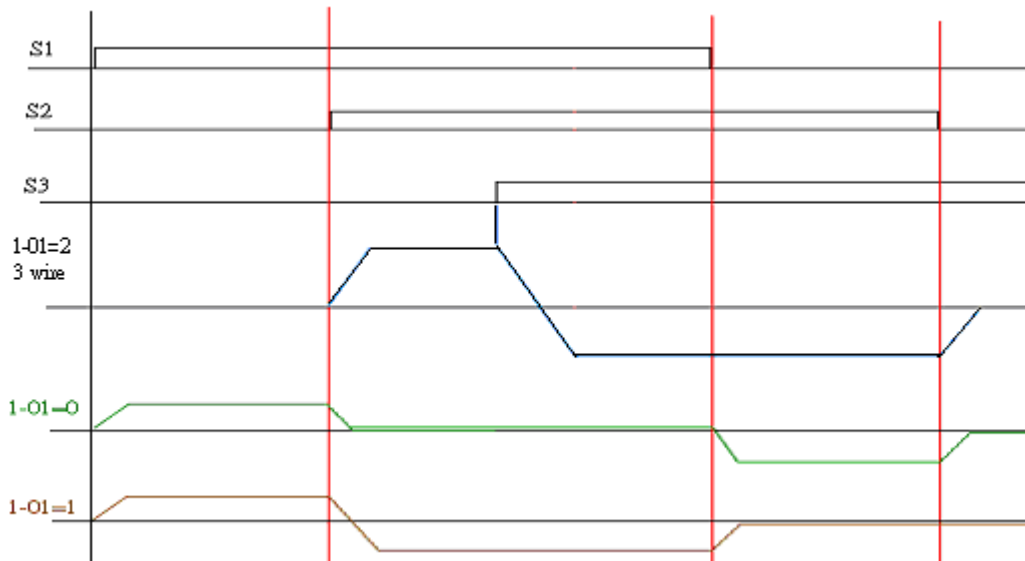

※Note: 1-02=0001, the reverse command is unavailable.

1-02 : Prohibition of Reverse Operation 0000: Enable Reverse Command
0001: Disable Reverse Command

1-02=0001, the reverse command is invalid.

1-03 : Keypad Stop Button 0000: Stop Button Enable
0001: Stop Button Disable

1-03=0000, The STOP key is available for controlling the inverter to stop.

1-04 : Starting Method Selection 0000: Normal Start
0001: Enable Speed Search

1.) 1-04=0000: As starting, the inverter accelerates from 0 to target frequency in the set time.

2.) 1-04=0001: As starting, the inverter accelerates to target frequency from the detected speed of motor.

1-05 : Stopping Method 0000: Controlled Deceleration-to- Stop with DC Injection Braking (Rapid Stop)
0001: Free run stop

1.) 1-05=0000: the inverter will decelerate to 0Hz in preset deceleration time after receiving the stop command.

- 2.) 1-05=0001: the inverter will stop output as receiving the stop command. The motor will inertia free run to stop.

1-06 : Frequency Command Source Selection

0000: Set the Frequency with Keypad

0001: Potentiometer on Keypad

0002: External Analog Signal Input or Remote Potentiometer

0003: Up/Down Frequency Control Using MFIT (S1 - S6)

0004: Communication Setting Frequency

0005: Impulse frequency (S5) setting frequency (ver2.3)

- 1.) 1-06=0001, as one of the parameter in group 5-00~ 5-06 is set 16 and multifunction terminal is OFF, the frequency is set by the KNOB(VR for principal speed) on keypad. While the multifunction is ON, the frequency is set by analog signal (auxiliary speed) on terminal block (TM2).
- 2.) 1-06=0002, as one of the parameter in group 5-00~ 5-06 is set 16 and the multifunction terminal is OFF, the frequency is set by analog signal (principal speed) on terminal block (TM2), While the multifunction is ON, the frequency is set by the KNOB(VR for auxiliary speed) on keypad.
- 3.) Please refer to description of parameter group 5-00~ 5-06 (multifunction input terminals) for the function Up/Down terminal.
- 4.) The priority in reading frequency is PLC frequency control >traverse run >Jog> preset speed>▲▼ on keypad or Up / Down or communication control.
- 5.) Impulse frequency command input source should be setting as S5 terminal and need to coordinate with 5-10 frequency exchange times ratio. For example, the input value S5 is 4KHZ, 5-10 is 1.500 times, and output frequency is $40.00 * 1.5 = 60.00\text{HZ}$. 5-04(S5) should be setting as 19.

1-07:Keypad Operation with Up/Down Keys in Run Mode

0000: 'Enter' must be pressed after frequency change with Up/Down Keys on keypad.

0001: Frequency will be changed directly when Up/Down Keys are Pressed

Parameter Group 2 - Manual/Automatic Restart Modes

2-00: Momentary Power Loss and Restart

0000: Momentary Power Loss and Restart Disable

0001: Momentary Power Loss and Restart is Enable

0002: Momentary Power Loss and Restart Enable while CPU is Operating.

2-01 : Momentary Power Loss Ride-Thru Time(sec): 0.0 - 2.0 second

- 1.) As start of the other load of power supply results in lowering the voltage below the under voltage level, the inverter will stop output at once. If the power supply recovers in the 2-01 preset time, it will spin start tracing from the trip frequency, or the inverter will trip with 'LV-C' displayed.
- 2.) The allowable power loss time differs with the models. The range is from 1second to 2 second.
- 3.) 2-00=0000: as power lost, the inverter will not start.
- 4.) 2-00=0001: if the loss time is less than the value of 2-01, the inverter will Spin Start in 0.5 second as the power supplied and restart times are infinite.
- 5.) 2-00=0002: the power lost for long time, before the inverter lost the control power for the CPU, the inverter will restart according to the 1-00 and 2-04 setting and status of external switch as the power resupplied.

※Note: 1-00=0001, 2-04=0000, 2-00=0001or 0002 after power lost for a long time, please OFF the power and power switches in case of injury to person and machine by the resupplied power.

2-02: Auto restart Delay Time :0 ~ 800.0 second

2-03: Number of Auto restart Attempts :0 ~ 10 times

- 1.) 2-03=0: the inverter will not auto restart as trip for accident.
- 2.) 2-03>0, 2-02= 0:
The inverter will conduct SPIN START in 0.5 second after trip for accident. The motor will inertia run to frequency at the trip stop, then according to setting accelerate or decelerate time to target frequency.
- 3.) 2-03>0, 2-02>0:
The output will be stopped for a period which is determined by the 2-02 after accident trip. Then, spin start to present target frequency.
- 4.) As the inverter is set in braking deceleration or DC braking, it will not perform restart after accident.

2-04 : Start Method:

0000: Enable Speed Search

0001: Normal Start

- 1.) 2-04=0000 : the inverter will detect motor speed and accelerated the setting frequency as speed search enable.
- 2.) 2-04=0001 : the inverter will accelerated the motor speed from stop (zero speed) to setting frequency.

2-05 :Direct running after power up:

0000: Enable Direct Running After Power Up

0001: Disable Direct Running After Power Up

! Danger:

- 1.) 2-05=0000 and the inverter is set external terminal controlled (1-00=0001), if the run switch is ON as power is supplied, the inverter will auto start. It is recommend that to cut off the power switch and run switch in case of injury to persons or machine as power is resupplied.
- 2.) 2-05=0001 and the inverter is set external terminal controlled (1-00=0001), if the run switch is ON as power is supplied, the inverter will not auto start and flash STP1. It is necessary to OFF the run switch and then ON to normally start.

2-06 : Delay-ON Timer (seconds): 0 ~ 300.0 second

As power on and 2-05=0000, the inverter will perform auto restart in the setting time for delay.

2-07: Error reset mode setting 0000: Enable Reset Only when Run Command is Off

0001: Enable Reset when Run Command is On or Off

2-07=0000 as the inverter is detected the accident, please cut off the Run switch to perform reset, or restarting does not work.

2-08: Kinetic Energy Back-up Deceleration Time:0.00~25.00 second

2-08 = 0 KEB function disable

2-08 ≠ 0 KEB function enable

Ex: 220V system

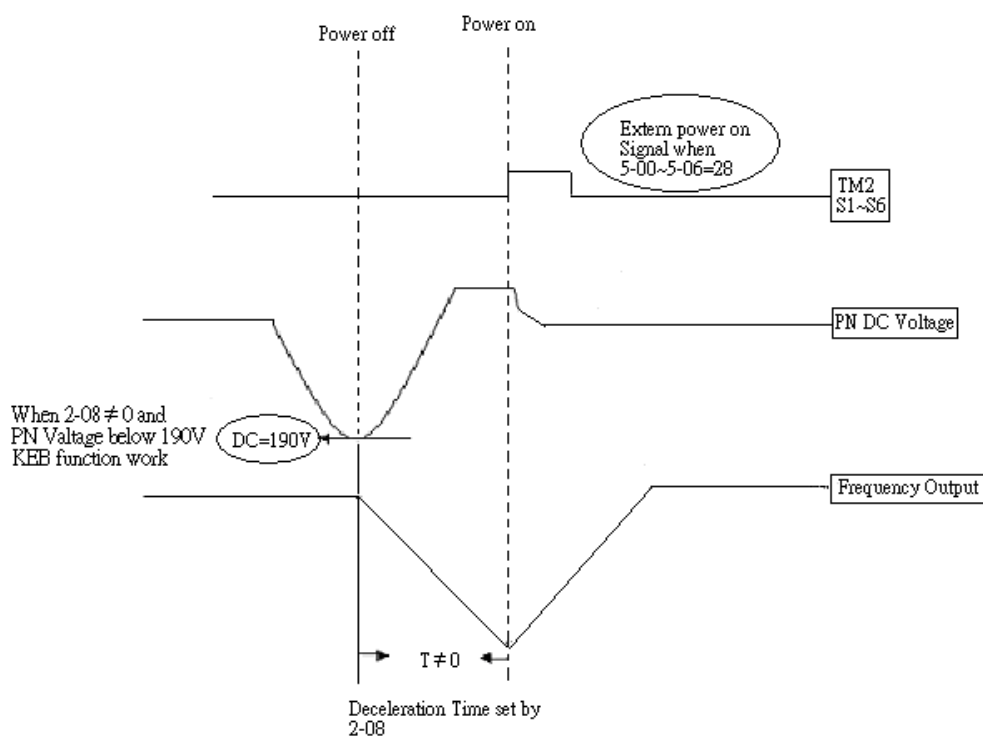

※NOTE:

1. When 2-08 ≠ 0, the momentary power loss and Restart is disabled, the inverter will do KEB Function.
2. When power off, CPU detect the DC Voltage. KEB function enable when DC Voltage below than 190V (220V system) or 380V (440V system).
3. When KEB function enabled, the inverter decelerate to zero by 2-08, and the inverter stop.
4. IF the power on signal enabled during the KEB function, the inverter accelerate to original frequency.

Parameter Group 3 - Operating Parameters

3-00: Frequency Upper limit(Hz) : 0.01 - 650.00

3-01: Frequency Lower limit(Hz) : 0.01 - 650.00

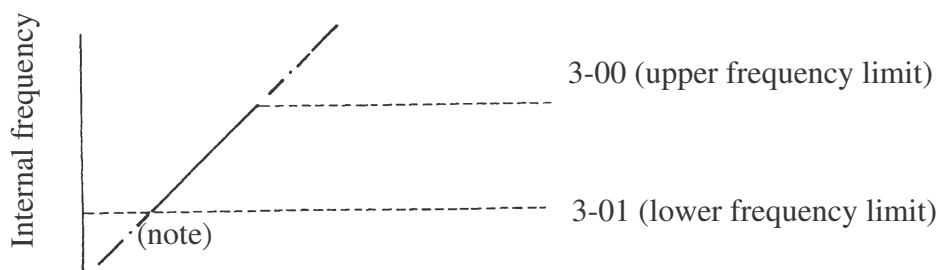

※Note: When 3-01 = 0 Hz and frequency command is 0 Hz, the inverter will stop at 0 speed.
When 3-01 > 0 Hz and frequency command \leq 3-01, the inverter will output 3-01 preset value.

3-02 : Acceleration Time #1 (second) : 0.1 – 3600.0

3-03 : Deceleration Time #1 (second) : 0.1 – 3600.0

3-04 : S Curve of First Acceleration Stage (second) : 0.0 – 4.0

3-05 : S Curve of Second Acceleration Stage (second) : 0.0 – 4.0

3-06 : Acceleration Time #2 (second) : 0.1 – 3600.0

3-07 : Deceleration Time #2 (second) : 0.1 – 3600.0

3-08 : Jog Acceleration Time (second) : 0.1 – 25.5

3-09 : Jog Deceleration Time (second) : 0.1 – 25.5

1.) Formula for calculating acceleration and deceleration time: The denominator is base on the rated frequency of motor.

$$\text{Acceleration time} = 3-02 \text{ (or } 3-06) \times \frac{\text{Preset frequency}}{0-05}, \quad \text{Deceleration time} = 3-03 \text{ (or } 3-07) \times \frac{\text{Preset frequency}}{0-05}$$

2.)When 5-00 – 5-06 is set 06 (the second acceleration and deceleration time), the first acceleration/ deceleration/ S curve or the second acceleration/ deceleration/ S curve will be set by ON the external input terminal.

3.) When 5-00 – 5-06 is set 05 (Jog), Jog run is controlled by external terminals. The acceleration and deceleration action will be at Jog acceleration and deceleration time.

4.)When 5-00 – 5-06 is set as 05(Jog) and 06(acceleration and deceleration time toggle), to change the acceleration and deceleration time by ON the external terminals, and the list setting:

Function	Acc/ Dec time 1(3-02/3-03)	Acc/ Dec time 2 (3-06/3-07)	JOG Acc/Dec time (3-08/3-09)
preset value	1-06 determines the output frequency	1-06 determines the output frequency	Run at 6-01Jog frequency
5-00~5-05=05 Jog command	Off	Off	On
5-00~5-05=04 Toggle Acc/Dec time.	Off	On	Off

5.)When S curve time (3-04/3-05) is set as 0, the S curve is useless. Namely, acceleration and deceleration

is at line.

6.)When S curve time (3-04/3-05) is larger than 0, the acceleration and deceleration action is as following diagram.

7.)Regardless of the stall prevention period, actual acceleration and deceleration time =preset acceleration / deceleration time + S curve time. For example: acceleration time = 3-03+ 3-04。

8.)During acceleration and deceleration process, there might be residual error in acceleration and deceleration toggling. Please set the S curve time as 0 (3-04/3-05), if you need to toggle acceleration and deceleration time in acceleration / deceleration process.

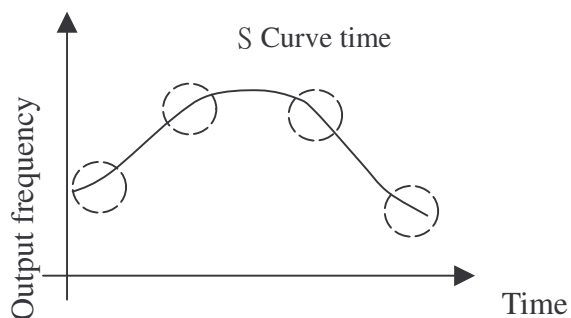

3-10 : DC Injection Brake Start Frequency (Hz) : 0.1 – 10.0

3-11 : DC Injection Brake Level (%) : 0.0 – 20.0

3-12 : DC Injection Brake Time(second) : 0.0 – 25.5

3-12 / 3-10 is the action time and start frequency of DC braking, as graph below:

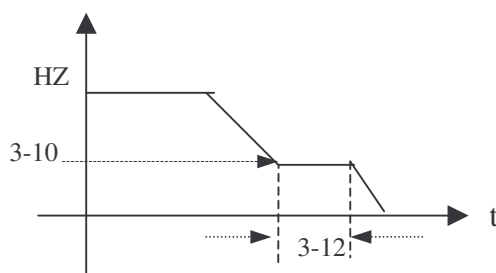

The upper setting of 3-11 will be corrected 20.0 after manual V2.3.

3-13 : Skip Frequency #1 (Hz) : 0.00 –650.00

3-14 : Skip Frequency #2 (Hz) : 0.00 –650.00

3-15 : Skip Frequency #3 (Hz) : 0.00 –650.00

3-16 : Skip Frequency Bandwidth (± Hz) : 0.00 –30.00

Example: as 3-13is set as 10.0Hz / 3-14 as 20.0 Hz / 3-15a s 30.0 Hz / 3-16 as 2.0Hz

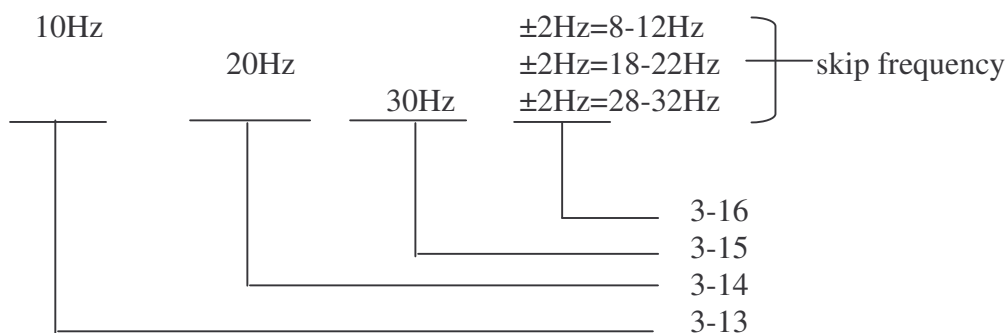

3-17: Parameter lock function**0000: Enable all Functions****0001: 6-00 - 6-08 cannot be changed****0002: All Functions Except 6-00 - 6-08 cannot be changed****0003: Disable All Function****3-18: Copy Unit****0000: Disable****0001: Inverter to Copy Unit****0002: Copy Unit to Inverter****0003: Verify**

- 1.) 3-18=0000: Inverter can not copy parameter.
- 2.) 3-18=0001: Copy the inverter parameters to module.
- 3.) 3-18=0002: Copy the module parameters to inverter.
- 4.) 3-18=0003: Copy the parameters to inverter or module to mutually verify the parameters.

※Note: The copy function is available for the models with same capacity.

3-19: Fan Running Controlling**0000: Auto (Depend on temp.)****0001: Operate while in RUN Mode****0002: Always Run****0003: Always Stop**

- 1.) 3-19=0000: The fan run as the inverter senses temperature rises. Thusly, extend the service period.
- 2.) 3-19=0001: The fan runs while the inverter is running.
- 3.) 3-19=0002: The fan is continuously running regardless of the action of the inverter.
- 4.) 3-19=0003: The fan is always stopping regardless of the action of the inverter.

※Note: Depend on the hardware, the function is disable at 20HP above of 440V class. The fan is running after the inverter power on.

3-20: Energy Saving Mode Operation 0000: Disabled**0001: Controlled by MFIT at Set Frequency****3-21: Energy saving operation gain (%): 0-100**

- 1.) In terms of FAN, PUMP or other heavy inertia loads which need greater start torsion, while in operation they need not so high torsion. Consequently, to decline the output voltage to saving energy by setting 3-20 is necessary.
- 2.) 5-00 ~5-06(Multifunction input terminal) set as10 to saving energy.
- 3.) 3-20=0001, If the multifunction terminal is set as 10 (energy saving control terminal), the output voltage will gradually decline to 'original voltage'×'3-21' preset value as the terminal' is ON. The output voltage will rise to original voltage as the terminal is OFF.

※Note: 1.The declining and rising speeds of voltage for energy saving is same as the ones for SPEED SEARCH.

2. Energy saving mode is only available under V/F mode. (0-00 = 0002)。

3-22: Carrier Frequency (KHz) : 2-16

3-22	Carrier Frequency	3-22	Carrier Frequency	3-22	Carrier Frequency	3-22	Carrier Frequency
2	2KHz	6	6KHz	10	10KHz	14	14KHz
3	3KHz	7	7KHz	11	11KHz	15	15KHz
4	4KHz	8	8KHz	12	12KHz	16	16KHz
5	5KHz	9	9KHz	13	13KHz		

※Note: The external electronic components maybe interfered, more serious, even the motor vibration due to cutting of the high carrier frequency waveform, although the inverter provides low noise environment in running. Thusly, it is necessary to regulate the carrier frequency.

3-23 : Center Frequency (CF) of Traverse Run(%) : 2-16

3-24 : Amplitude (%) : 0.1-20.0

3-25 : Amplitude Drop (%) : 0.0-50.0

3-26 : Acceleration Time (s) : 0.5-60.0

3-27 : Deceleration Time (s) : 0.5-60.0

3-28 : Deviated traverse (X upper deviation) (%) : 0.0-20.0

3-29 : Deviated traverse (Y lower deviation) (%) : 0.0-20.0

Traverse Run is defined as adding a triangle wave to the basic operation frequency of inverter output frequency at the preset acceleration and deceleration time. The action is as the graph below:

3-23: Traverse Run Center frequency (%)

3-24: Amplitude (%)

3-25: Amplitude Drop (%)

3-26: Acceleration Time (s)

3-27: Deceleration Time (s)

3-28: Deviated traverse (X upper deviation)

3-29: Deviated traverse (Y lower deviation)

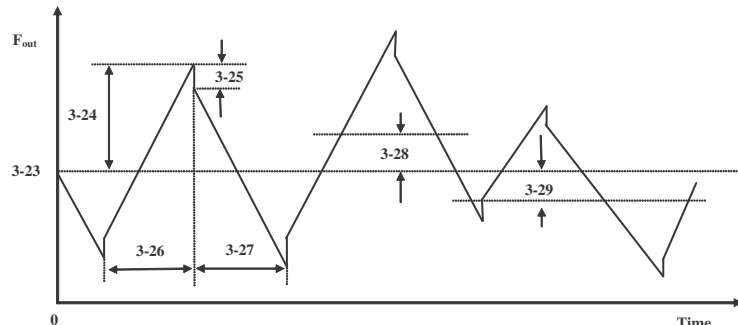

1) The traverse run is available as the run command and the terminal (5-00~5-05=0025) for such operation both ON. Inverter operating, the traverse run is ready when the inverter output frequency reaches center frequency (3-23). During acceleration to center frequency, the acceleration time is at the originally preset value (3-02/3-06). When the traverse run is OFF or the Inverter is OFF, the deceleration time is also at original preset value (3-03/3-07). However, in traverse running, the inverter is at traverse run acceleration time (3-36) and deceleration time (3-27). The action is as follow diagram:

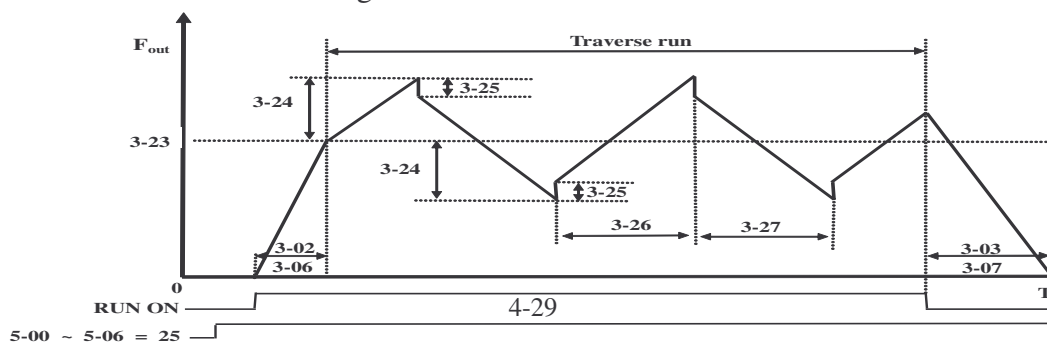

5-00 ~ 5-06 = 25

- 2) During traverse run, the center frequency could be controlled by the multifunction input terminals. However, the X up deviation and Y low D deviation can not be input at the same time. If they are input at the same time, the inverter will maintain the original center frequency. The motion is as the graph below:

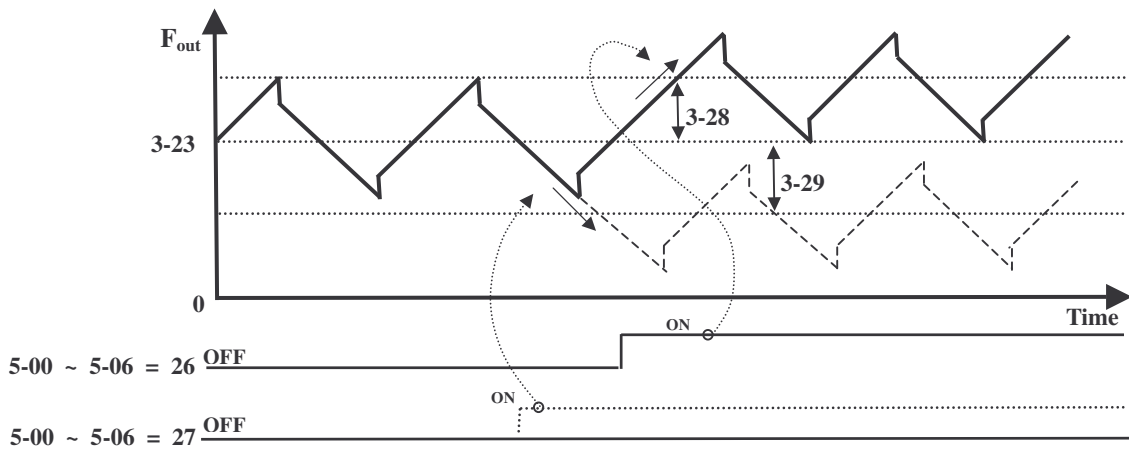

- 3) The stall prevention is idle in the acceleration and deceleration time of traverse run. Whereas, it is valid during first acceleration to center frequency process when the Function of traverse run is OFF or the inverter is in deceleration time after the STOP command is received.
- 4) The frequency range of traverse run is restricted by the inverter upper and lower frequency limit. That is: if the (center frequency + Amplitude) is larger than Upper Limit, it will operate at upper frequency limit. And if (center frequency - Amplitude) is less than Lower Limit, vice versa.
- 5) During traverse run, all the preset values can't be modified such as (center frequency, amplitude, amplitude drop, acceleration time, deceleration time, traverse run upper deviation and lower deviation). The modified acceleration and deceleration time is priority to the original one, but not traverse run acceleration and deceleration time. The motion is as graph below:
- 6) The stall prevention protection is unavailable during traverse run acceleration and deceleration time. Thusly, it is must take into consideration to comply the actual system capacity with the proper inverter capacity when designing equipment.
- 7) Center frequency = 3-23*max. frequency(3-00)
 Amplitude = 3-24*center frequency
 Acceleration / Deceleration time = amplitude acceleration / deceleration time
 Amplitude Drop = 3-25*amplitude
 Deviated traverse (X upper deviation) = 3-28*traverse run center
 Deviated traverse (Y lower deviation) = 3-29* traverse run center
 If change the max. frequency of 3-00, reset 3-23~3-29 value is necessary.

Parameter Group 4 - Digital Display Operation Mode

4-00: Motor Current Display Selection:	0000: Disable Motor Current Display 0001: Enable Motor Current Display
---	---

4-01: Motor Voltage Display Selection:	0000: Disable Motor Voltage Display 0001: Enable Motor Voltage Display
---	---

4-02: DC Bus Voltage Display Selection:	0000: Disable Bus Voltage Display 0001: Enable Bus Voltage Display
--	---

4-03: PLC Status Display Selection:	0000:Disable PLC Status Display 0001:Enable PLC Status Display
--	---

The function is available for LCD operation keypad, but not for LED one.

4-04: Custom Units (Line Speed) Value :	0-9999
--	---------------

The max preset line value of 4-04 is equal to the rated frequency (0-05) of the motor. For instance, given line speed 1800 is equal to display 900 when output is 30Hz while the operation frequency is 60Hz.

4-05 : Custom Units (Line Speed) Display Mode
0000:Drive Output Frequency is Displayed
0001:Line Speed is Displayed in Integer (xxxx)
0002:Line Speed is Displayed with One Decimal Place (xxx.x)
0003:Line Speed is Displayed with Two Decimal Places (xx.xx)
0004:Line Speed is Displayed with Three Decimal Places (x.xxx)

The preset frequency is displayed as the inverter stops while the operation line speed is displayed as the inverter is running.

4-06: PID Feedback Display	0000:Disabled 0001:Enable
-----------------------------------	--

Keypad displays PID feedback value :

Parameter 5-05=20 (That is, S6 is set as the PID feedback analog terminal, refer to PID), 11-0=1(PID is enabled), and 4-06=1(Display S6 as PID analog feedback value 0~100, the formula as follow:)

If feedback signal is 0~10V, (12-6=0000), keypad display value = $(S6/10V)*100$

If feedback Signal is 4~20mA, (12-6=0001), keypad display value = $(S6/20mA)*100$

※Note: Please press DSP Key to switch between the output frequency and PID feedback value.

※Note: The inverter displays XXXF as Running, while XXXr as Stop.

Parameter Group 5-Multifunction Input Terminals (MFIT)

Multifunction input terminals (TM2 S1-S6/AIN) controlling :

5-00~06	0000: Forward/Stop Command *¹ 0001: Reverse/Stop Command *² 0002: Preset Speed # 1 (6-02) 0003: Preset Speed # 2 (6-03) 0004: Preset Speed # 3 (6-05) *³ 0005: Jog 0006: Acc/Dec time # 2 0007: Emergency Stop Contact A 0008: Base Block 0009: Speed Search Stop 0010: Energy Saving 0011: Control Signal Selection 0012: Communication Control Signal Selection 0013: Acc/Dec Disabled 0014: Up Command 0015: Down Command 0016: Principal/Auxiliary Speed 0017: PID Function Disabled 0018: Reset 0019: Encoder Input Terminal (Terminal S5) 0020: PID Feedback Signal A12 (Terminal S6) 0021: AI2 Bias Signal 1 Input (Terminal S6) 0022: AI2 Bias Signal 2 Input (Terminal S6) 0023: Analog Input (Terminal AIN) 0024: PLC Application 0025: Traverse Run 0026: Traverse Run Upper Deviation 0027: Traverse Run Lower Deviation 0028: Power Source Detect for KEB Function 0029: Emergency Stop Contact B
----------------	--

A. The terminals S1-AIN on terminal block (TM2) are multifunction input terminals. The above 30 functions can be set in these terminals.

B. Function Description for 5-00~06:

1. 5-00~06=0/1(Forward/Reverse/Stop)

As forward command is ON, the inverter runs while stops as OFF. The 5-00 factory set is forward.

As reverse command is ON, the inverter runs while stops as OFF. The 5-01factory set is reverse.

2. 5-00~06=2-4(Preset speed 1~3)

External multifunction input terminals are ON, the inverter is operation at the preset time, and the duration is determined by the time of the terminal ON. The corresponding frequency parameter is illustrated below:

3. 5-00~06=5(Jog)

To select Jog operation as ON the external input terminals. Now, the inverter operates at the Jog acceleration and deceleration time. The corresponding frequency parameter is illustrated below:

The priority order of frequency: Jog Speed→Preset Speed→Keypad frequency or external frequency signal

Multifunction terminal3 Preset value=04	Multifunction terminal 2 Preset value =03	Multifunction terminal 1 Preset value =02	Jog Command terminal Preset value =05	Output frequency preset value
0	0	0	0	6-00
X	X	X	1	6-01
0	0	1	0	6-02
0	1	0	0	6-03
0	1	1	0	6-04
1	0	0	0	6-05
1	0	1	0	6-06
1	1	0	0	6-07
1	1	1	0	6-08

4. 5-00~06=6 (toggle acceleration and deceleration time)

On the external input terminal, to select the acceleration 1/ deceleration 1/ S curve 1 or acceleration 2/ deceleration 2/ S curve 2.

5. 5-00~06=7 /29 : External Emergency Stop Contact A or B.

The inverter will decelerate to stop and Flash E.S as the emergency stop signal received regardless of 1-05 setting. After such signal released, OFF the operation switch then ON or Press Operation Key, the inverter will restart from the start frequency. If the emergency signal was released before the inverter stop completely, the inverter still carries out emergency stop. The 8-02/03 determines the action of the error terminal. As 8-02/0=0: the error terminal does not act when the external emergency signal input. While 8-02/03=9, the error terminal does act when emergency signal input.

6. 5-00~06=8 : Base Block

The inverter stop output as receiving STOP command, and the motor Free-Run stops.

7. 5-00~06=9 : Speed Search Stop

When starting, the inverter detects the present speed of the motor firstly, then, the inverter accelerates from the present speed to preset speed.

8. 5-00~06=10 : Energy-saving operation

In terms of FAN, PUMP or other heavy inertia loads which need greater start torque, while in operation they need not so high torsion. Thusly, to decline the output voltage is to saving energy.

The output voltage gradually declines as the multifunction terminal is ON. It will gradually increase (to the original voltage) as the Multifunction terminal is OFF.

※Note : The acceleration and deceleration speed of energy saving operation is the same as the speed of SPEED SEARCH.

9. 5-00~06=11 : Switch of the control signal

External switch terminal is OFF : 1-00/01 determines the operation signal and frequency signal.

External switch terminal is ON : Keypad controls the operation signal and frequency signal but not

controlled by 1-00/01.

10. 5-00~06=12 : Switch of the inverter controlling in communication

External switch terminal is OFF : in communication, the master (PC or PLC) can control the inverter operation and frequency signal and allowably modify the parameters, and the operation signals from Keypad and TM2 are idle. Furthermore, the keypad can only display the voltage, current and frequency, the parameters are readable and not writable, and Emergency Stop is valid.

External switch terminal is ON : in communication, the inverter is controlled by the keypad regardless of the setting of 1-00/1-06 and master. Under such circumstance, the master still can read and write the inverter parameters.

11. 5-00~06=13 : Disable acceleration and deceleration

The acceleration and deceleration action is unavailable till the forbid acceleration and deceleration signals are released. The action is illustrated in the graph below:

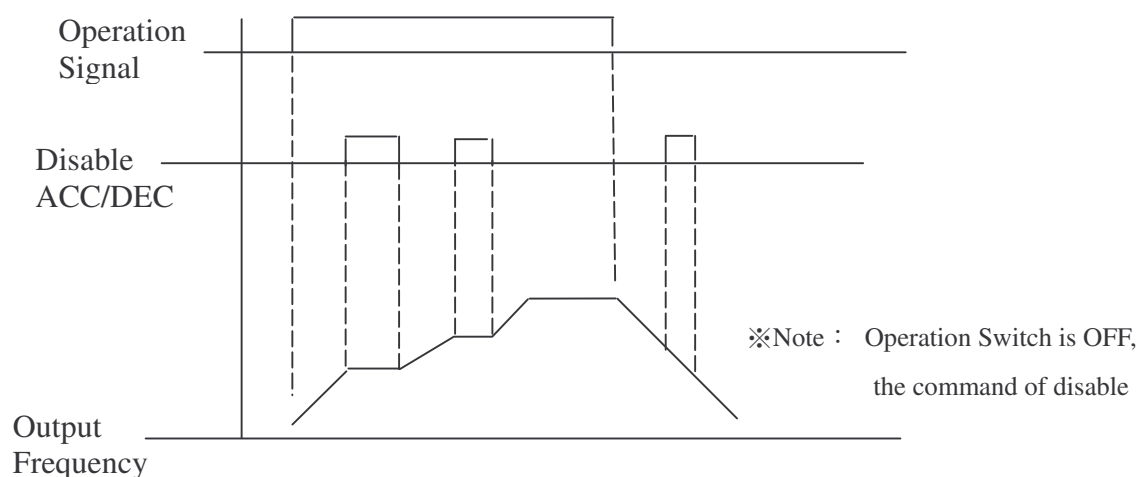

12. 5-00~06=14,15 : UP / DOWN Function (Actual ACC/DEC time is base on the setting) :

- (1) Please set 1-06 = 3 if you want to use the UP/DOWN Function, and the other frequency signals are useless.
- (2) Set 5-08 = 0 and 5-09 = 0, the inverter accelerates to the preset value of 6-00 when the operation terminal is ON. Then, it maintains the certain speed. As the inverter receives the UP/DOWN command, it will accelerate / decelerate till the command is released. The inverter runs at the certain speed. The inverter will ramp stop or Free-Run stop which is determined by the 1-05 as long as the inverter receives the STOP command. And the frequency of Stopping will be stored in 6-00. The UP/DOWN KEY is invalid as the inverter stops. It is necessary to use the Keypad to modify the preset parameter.
- (3) Set 5-08 = 1, the inverter will operate from 0Hz when the operation terminal is ON. The action of UP/DOWN is as above description. The inverter will ramp stop or free-run stop which determined by 1-05 setting when as it receiving the Stop Command and back to 0Hz. The next operation will start at 0 Hz.
- (4) That UP/Down Signal Simultaneously act are invalid

(5) 5-09 ≠ 0, the inverter will accelerate to the setting of 6-00 and maintain at the speed. When the UP/Down terminal is On, setting frequency is present value 6-00 ± 5-09, and the inverter will accelerate/ decelerate to frequency 6-00. The upper frequency limit and lower frequency limit also restrict the operation. If the signal of UP/ DOWN is maintained over 2 seconds, the inverter will begin to accelerate/ decelerate. If 5-09=0, the operation is the same, till the UP/ DOWN signal stops. Please refer to the time diagram of 5-09.

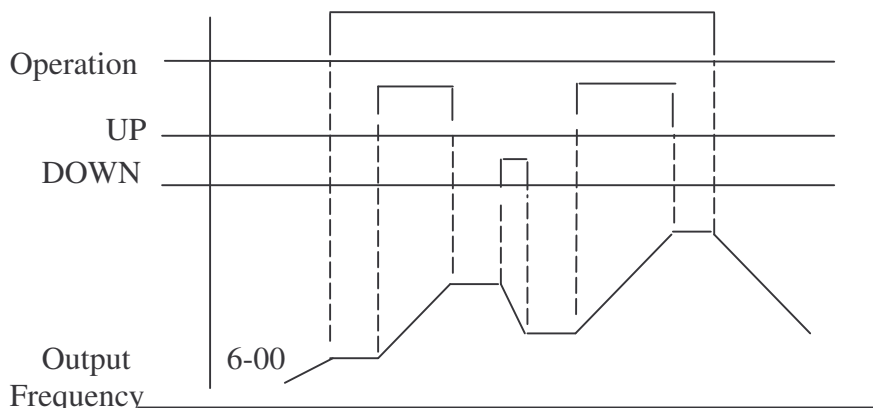

13. 5-00~06=16 Principal/Auxiliary speed toggle

Multifunction terminal = OFF, the frequency is set by the VR (Master Speed) on the Keypad. Whereas, Multifunction terminal = ON, the frequency is set by the analog signal terminal (Auxiliary Speed) on the TM2 on terminal Block.

14. 5-00~06=17(PID Function Disable)

The PID Function Disable is ON. PID is not controlled by 11-0, while OFF, it is controlled by 11-0.

15. 5-00~06=18(Reset Command)

The Reset command is same as Reset Key on the panel is ON. The command is OFF, and the inverter does not response. The factory set of 5-05 is Reset command.

16. 5-04=19 (Encoder Input terminal)

The multifunction terminal S5 is set 19 means it is the input terminal for PLC program Encoder.

17. 5-05=20 (PID feedback input terminal)

The multifunction terminal S6=20 means the PID feedback input terminal and 0~10V (0~ 20 mA) or 2~10V (4~20mA) is available by the setting of 11-0.

18. 5-05=21 /22(Bias signal 1/2 input)

To regulate the Offset of the Keypad VR or AIN analog input, only the signal of 0~10V (0~ 20 mA) or 2~10V (4~20mA) is available.

5-05=21 Function

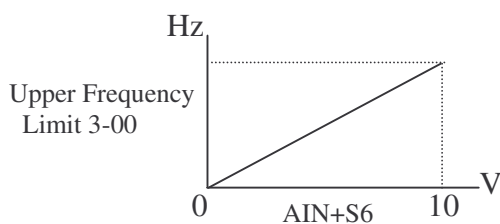

5-05=22Function * The value is 0 when AIN+(S6-5V) < 0

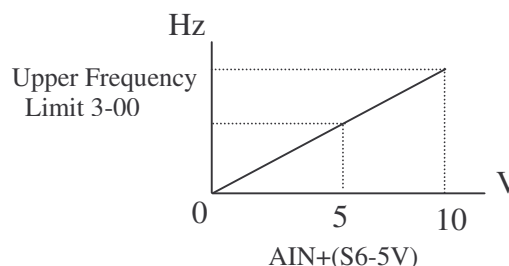

19. 5-06=23 (Analog input AIN)

The multifunction terminal AIN = 23. The action is provided for setting the frequency.

20. 5-00~06=24 (PLC Application)

The multifunction terminal S1-AIN=24, which means the terminal is for PLC application.

The terminal is provided for the PLC program input.

21. 5-00~06=25 (Traverse Run); 5-00~06=26(Upper Deviation Traverse); 5-00~06=27(Lower deviation Traverse).

The motion description refers to 3-23~3-29 for detail description.

22. 5-00~06=28 (Power Source Detect for KEB Function)

Please refer to the description of 2-08

Digital /Analog input signal scan times:**5-07: Multifunction terminal S1 ~ S6 and AIN signal confirm the scan times (mSec X 4) , 1~100 times**

1. TM2 terminal used as scanning, if there are same signals continuously input for N times (Namely, Scan times), the inverter will treat the signal as normal. During performing the signal, if the scan times are less than N, the signal will be as noise.
2. Each scan period is 4ms.
3. The user can specify the scan times interval duration according to the noise environment. If the noise is serious, upper modify the value of 5-07, but the response speed will be slow down.
4. Note: If the S6 and AIN is for digital signal, the voltage level for digital signal above 8V is treated as ON, below 2V is OFF.

Stop Mode Using MFIT:**5-08:**

0000: When Up/Down is used, the preset frequency is hold as the inverter stops, and the UP/Down is idle.

0001: When Up/Down is used, the preset frequency is reset to 0 Hz as the inverter stops.

0002: When Up/Down is used, the preset frequency is hold as the inverter stops, and the UP/Down is available.

- (1) Set 5-08=0, the inverter will accelerate to the speed of 6-00 as receiving the Run command and run at such certain speed. The inverter begins to accelerate (decelerate) as the UP (Down) terminal is energized. The inverter will hold the speed as the UP/DOWN command released. When the Run Signal releases, the inverter will ramp stop or stop output (determined by the 1-05). It will store the frequency when the operation signal disappeared. UP/DOWN keys are idle when the inverter is stop. The keypad is available for you modify the preset frequency (6-00). If 5-08=0002, the UP/Down is available as the inverter stops.
- (2) Set 5-08=1, as the Run terminal is energized, the inverter operates from 0 Hz, the Function of UP/DOWN is same as the above description. When the Run Signal released, the inverter will ramp stop or stop output (determined by 1-05) .And back to 0 Hz. The following operation will always begin from 0 Hz.

Step of Up/Down Function (Hz):**5-09 : Up/Down (Hz) 0.00 – 5.00**

There are two modes covered below:

- (1) 5-09 = 0.00, the function is disable. The operation is just as the original one. As UP terminal is ON, the frequency increases while the DOWN terminal is ON, the frequency decreases. (Refer to the following graph).

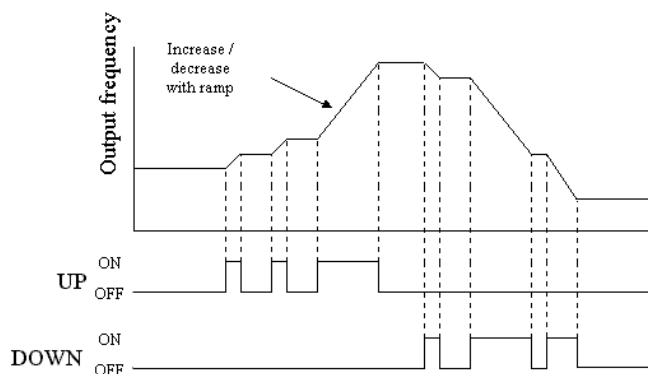

- (2) 5-09 = 0.01 to 5.00, UP/ DOWN terminal ON, that equivalent to increase/ decrease the frequency of 5-09. If the pressing is over 2second, revive the original UP/DOWN mode (Please refer to the following diagram)

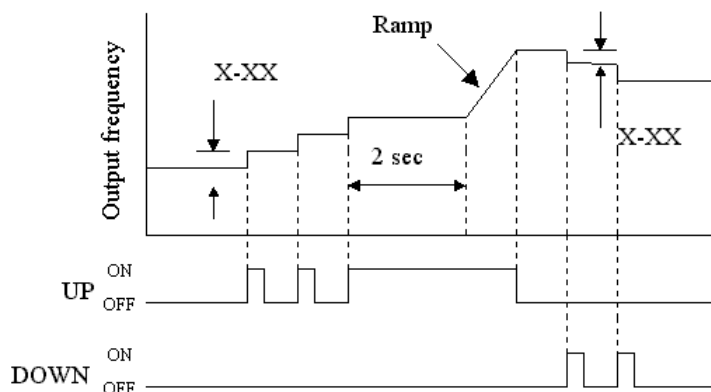
**Encoder Impulse Ratio :****5-10 Impulse input frequency time ratio**

When frequency source 1-06 be setting as 0005, the impulse signal frequency will be according to this parameter to decide to the real inside frequency of inverter.

The inside calculate formula : $\text{Frequency} = S5(\text{impulse frequency}) * 5-10(\text{times ratio})$

For example, when S5 impulse is 1KZ(1000), and 5-10 be setting as 1.50 times. The inverter frequency command is $1000 * 1.5 = 1500 = 15.00\text{HZ}$. The frequency accuracy of S5 is by base of 100, 1K(1000) present 10.00 HZ.

Reference Source 2 :**5-11 Auxiliary frequency source can be selected**

When frequency source command setting as impulse command , (1-06= 5)

If master speed operating(5-00~5-06 setting to 16 and the terminal is OFF), frequency running as impulse frequency.

If auxiliary speed operating (5-00~5-06 setting to 16 and the terminal is ON), frequency should be decided by 5-11 setting.

Ex. The action process refer to below:

5-11= 0, frequency refer to 6-00.

5-11= 1, frequency refer to the VR analog signal on the Keypad.

5-11= 2, frequency refer to the VR analog signal on TM2.

5-11= 3, frequency refer to the frequency value which is calculated by Up/Down on TM2.

5-11= 4, frequency refer to the input communication frequency.

Parameter Group 6- Jog and Preset (MFIT) Speed Setting on Keypad

Jog and Preset (MFIT) Speed Setting on Keypad :

6-00~08: Set Jog and preset speed by Keypad

A. 5-00~06=2-4(preset speed 1~3)

The external multifunction terminal = ON, the inverter operates at preset speed. The operation time of the 8 stages is base on the ON time of the terminal. Please refer to the corresponding parameters list:

B. 5-00~06=5(Jog terminal)

The external multifunction terminal = ON, the inverter operates in Jog acceleration time/ Jog decelerate time/ON

Function Code No.	LCD Display	Description	Range/Code
6-00	(Keypad Freq)	Keypad Frequency (Hz)	0.00 - 650.00
6-01	(Jog Freq)	Jog Frequency (Hz)	0.00 - 650.00
6-02	(Preset Speed #1)	Preset Speed # 1 (Hz)	0.00 - 650.00
6-03	(Preset Speed #2)	Preset Speed # 2 (Hz)	0.00 - 650.00
6-04	(Preset Speed #3)	Preset Speed # 3 (Hz)	0.00 - 650.00
6-05	(Preset Speed #4)	Preset Speed # 4 (Hz)	0.00 - 650.00
6-06	(Preset Speed #5)	Preset Speed # 5 (Hz)	0.00 - 650.00
6-07	(Preset Speed #6)	Preset Speed # 6 (Hz)	0.00 - 650.00
6-08	(Preset Speed #7)	Preset Speed # 7 (Hz)	0.00 - 650.00

Priority in reading the frequency: Jog > Preset speed > Keypad frequency or external frequency signal

Multifunction terminal3 Preset value=04	Multifunction terminal 2 Preset value =03	Multifunction terminal 1 Preset value =02	Jog Command terminal Preset value =05	Output frequency preset value
0	0	0	0	6-00
X	X	X	1	6-01
0	0	1	0	6-02
0	1	0	0	6-03
0	1	1	0	6-04
1	0	0	0	6-05
1	0	1	0	6-06
1	1	0	0	6-07
1	1	1	0	6-08

Parameter Group 7 - Analog input signal operation mode

Analog Input Signal Operation Mode:

7-00:AIN Gain(%) 0 - 200

7-01:AIN Bias(%) 0 - 100

7-02:AIN Bias Selection: 0000:positive 0001:Negative

7-03:AIN Slope: 0000:positive 0001:Negative

7-04: AIN signal verification Scan Time (AIN, AI2) 1-100 (× 4mSec)

7-05: AI2 Gain (%) (S6) 0 - 200

1. 7-02 = 0 : 0V(0mA) corresponding to Lower Frequency Limit. , 10V (20mA) corresponding to Upper Frequency Limit.
2. 7-02 = 1 : 10V(20mA) corresponding to Lower Frequency Limit , 0V (0mA) corresponding to Upper Frequency Limit.

3. 12-6 = 0 : 0~10V(0~20mA)

$$F = I * (3-00) / 20 \quad I \geq 0 ; \text{ SW2} = I \quad \text{or} \quad F = V * (3-00) / 10 \quad V \geq 0 ; \text{ SW2} = V$$

= 1 : 2~10V(4~20mA)

$$F = (I-4) * (3-00) / 16 \quad I \geq 4 ; \text{ SW2} = I$$

$$F = 0 \quad I < 4$$

$$F = (V-2) * (3-00) / 8 \quad V \geq 2 ; \text{ SW2} = V \quad \text{or}$$

$$F = 0 \quad V < 2$$

The setting of figure 1:

	7-00	7-01	7-02	7-03	7-05
A	100%	50%	0	0	100%
B	100%	0%	0	0	100%

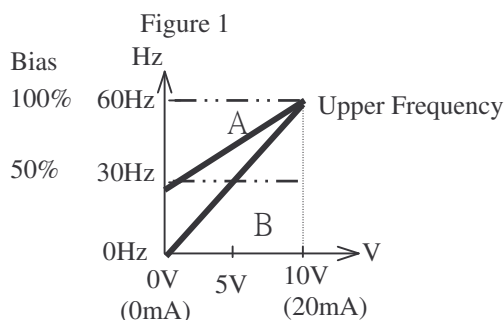

The setting of figure2:

	7-00	7-01	7-02	7-03	7-05
C	100%	50%	0	1	100%
D	100%	0%	0	1	100%

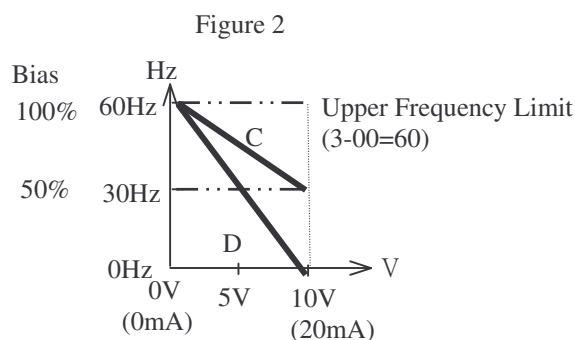

The setting of figure 3:

	7-00	7-01	7-02	7-03	7-05
E	100%	20%	1	0	100%

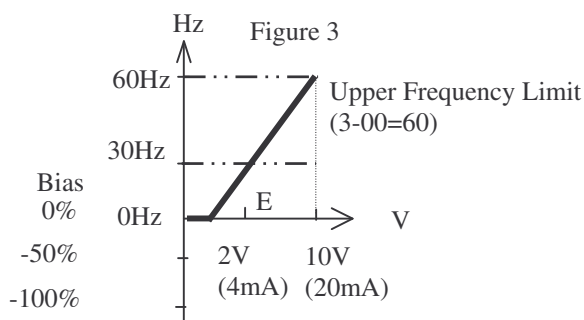

The setting of figure 4:

	7-00	7-01	7-02	7-03	7-05
F	100%	50%	1	1	100%

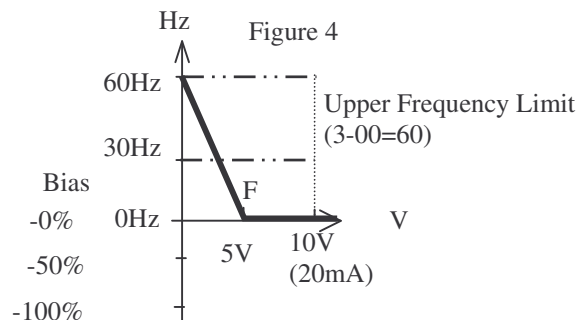

3. The inverter reads the average value of A/D signals once per (7-04×4ms). Users can determine scan intervals according to noise in the environment. Increase 7-04 in noisy environment, but the respond time will increase accordingly.

Parameter Group 8 - Multifunction output terminal and output signal operation mode

Multifunction analog output control:

8-00 : Analog Output Voltage Mode :

- 0000: Output frequency**
- 0001: Frequency Setting**
- 0002: Output voltage**
- 0003: DC Bus Voltage**
- 0004: Motor current**
- 0005: FEEDBACK Signal of PID**

8-01 : Analog Output Gain = 0 ~ 200%

The multifunction analog output terminal of the terminal block (TM2), is 0~10Vdc analog output. The output type is determined by the 8-01. The function of 8-01 is: when there is tolerance for the external voltage meter and peripheral equipment, please regulate 8-00.

The FEEDBACK value of PID (That is the input voltage and current of S6) outputs analog value from FM+ terminal. (decide to parameter 4-06) The value is corresponding to the input signal 0~10V(0 ~ 20 mA) or 2~10V (4~20mA).

※Note: The max output voltage is 10V due to the circuit, even the output voltage should be higher than 10V.

Multifunction output terminals control:

8-02 : RELAY1(R1C , R1B , R1A terminal on TM2)

8-03 : RELAY2(R2C , R2A terminal on TM2)

- 0000: Run**
- 0001: Frequency Reached (Target Frequency) (Set Frequency \pm 8-05)**
- 0002: Set Frequency (8-04 \pm 8-05)**
- 0003: Frequency Threshold Level (> 8-04) - Frequency Reached**
- 0004: Frequency Threshold Level (< 8-04) - Frequency Reached**
- 0005: Over torque Threshold Level**
- 0006: Fault**
- 0007: Auto-restart**
- 0008: Momentary AC Power Loss**
- 0009: Rapid Stop Mode**
- 0010: Coast-to-Stop Mode**
- 0011: Motor Overload Protection**
- 0012: Drive Overload Protection**
- 0013: PID Feedback Signal Break**
- 0014: PLC Operation**
- 0015: Power On**

8-04 : Frequency Reached Output Setting =0 ~ 650Hz

8-05 : Frequency Output Detection Range =0 ~ 30Hz

8-02/03= 01 :

The preset frequency is reached ($\pm 8-05$)

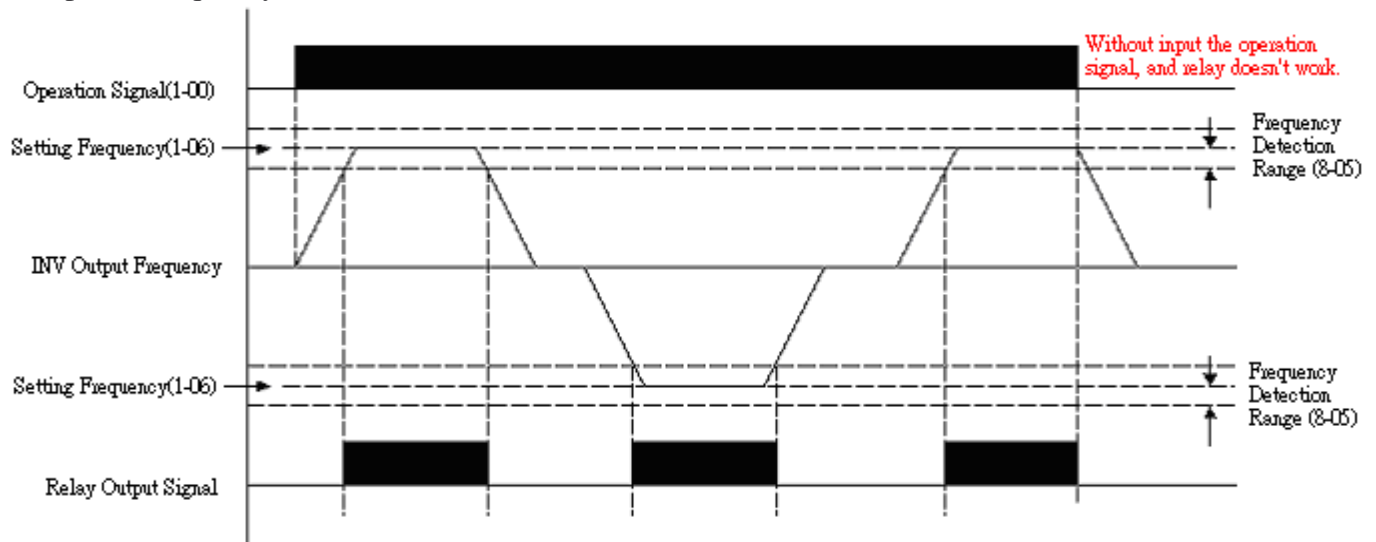

(Multifunction output terminal (8-02 / 8-03) =1)

8-02/3= 02 :

Arbitrary frequency consistency $F_{out} = 8-04 \pm 8-05$

Operation Frequency Reached Arbitrary Frequency (8-04+ / 8-05)

Operation conditions :

- A. Input Frequency-Frequency Command(1-06) < Frequency Threshold Level(8-05)
- B. Input Frequency-Detecting Level (8-04) < Frequency Threshold Level(8-05)

Without input the operation signal or command frequency no consistency, and relay doesn't work.

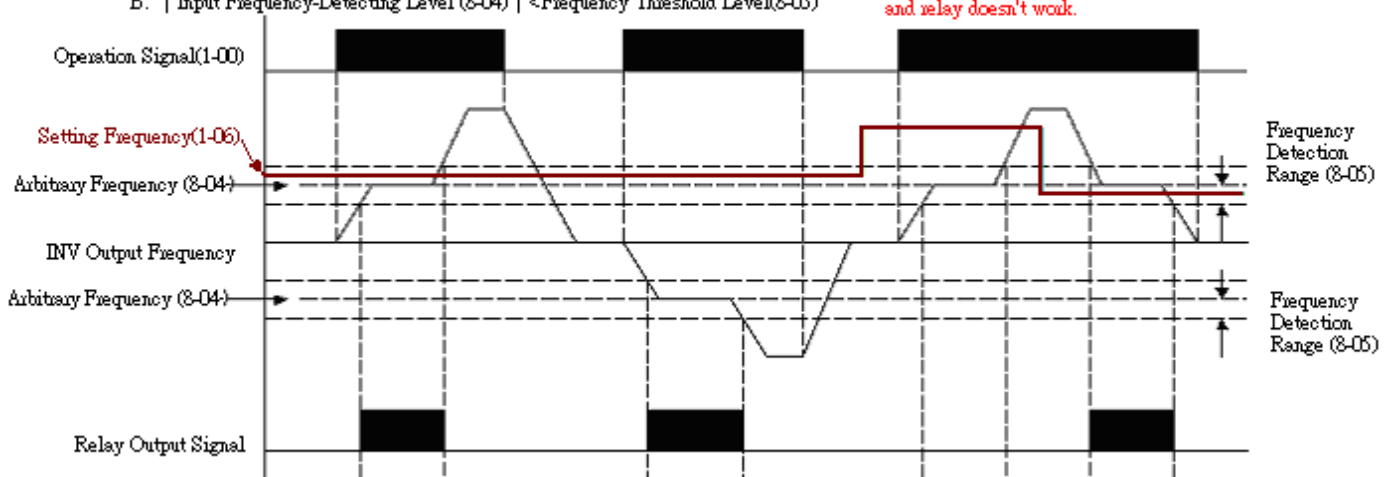

(Multifunction output terminal (8-02 / 8-03) =2)

8-02/3 = 03 : frequent detection $F_{out} > 8-04$

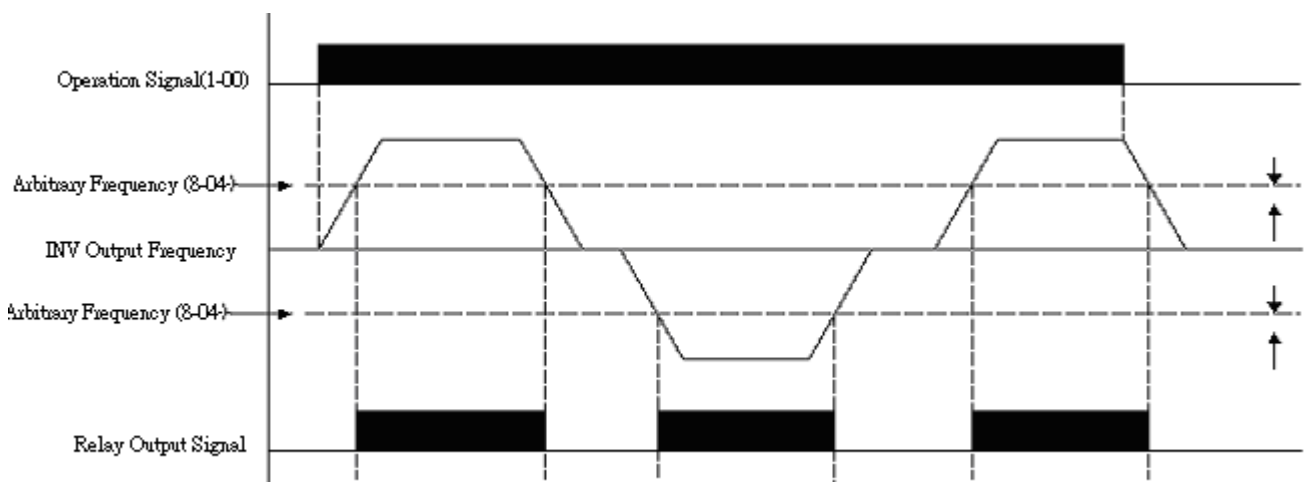

(Multifunction output terminal (8-02 / 8-03) =3)

8-02/3 = 04 : frequent detection $F_{out} < 8-04$

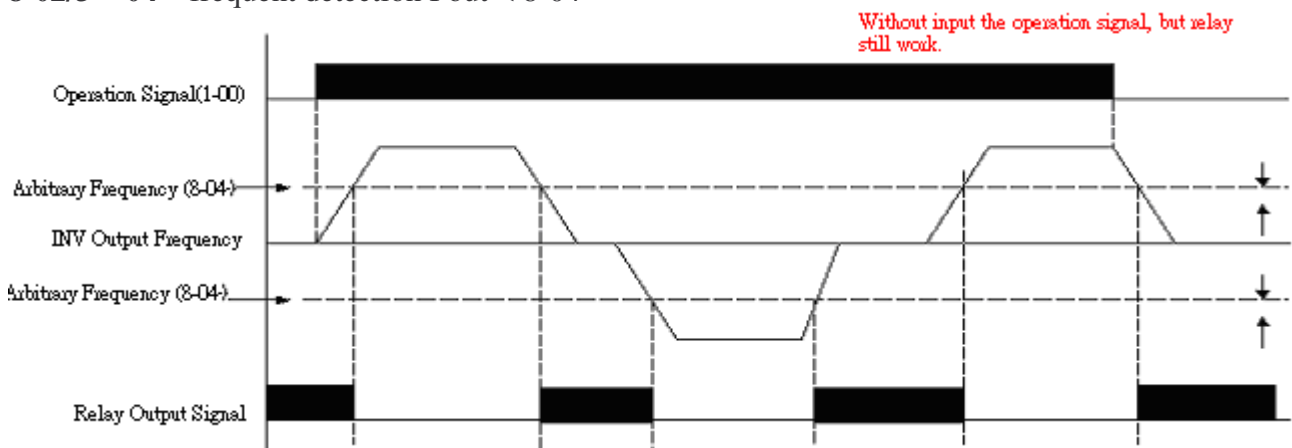

8-02/3= 05 : over torque detection

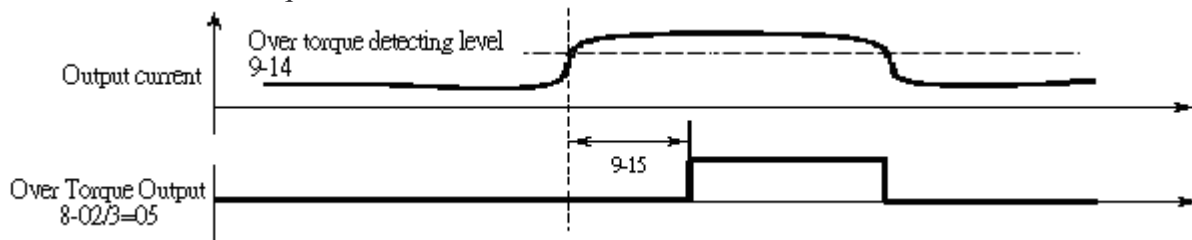

Parameter Group 9 – Drive and Load Protection Modes

- 9-00 : Trip Prevention Selection During Acceleration:**
0000 : Enable Trip Prevention During Acceleration
0001 : Disable Trip Prevention During Acceleration
- 9-01 : Trip Prevention Level During Acceleration: 50% ~ 300%**
- 9-02 : Trip Prevention Selection During Deceleration:**
0000 : Enable Trip Prevention During Deceleration
0001 : Disable Trip Prevention During Deceleration
- 9-03 : Trip Prevention Level During Deceleration: 50% ~ 300%**
- 9-04 : Trip Prevention Selection in Run Mode:**
0000 : Enable Trip Prevention in Run Mode
0001 : Disable Trip Prevention in Run Mode
- 9-05 : Trip Prevention Level in Run Mode: 50% ~ 300%**
- 9-06 : Trip Prevention Deceleration Time Selection in Run Mode:**
0000: Trip Prevention Deceleration Time Set by 3-03
0001: Trip Prevention Deceleration Time Set by 9-07
- 9-07 : Deceleration Time in Trip Prevention Mode (sec): 0.1 ~ 3600.0**

1. In acceleration, the inverter will delay the acceleration time if the time is too short resulting in the over current in order to prevent the inverter trips.
2. In deceleration, the inverter will delay the acceleration time if the time is too short resulting in the over voltage of DC VUS in order to prevent the inverter trips with 'OV' displayed.
3. Some mechanical characteristics (such as press) or unusual breakdown (seize due to insufficient lubrication, uneven operation, impurities of processed materials, etc.) will cause the inverter to trip, thus inconvenience users. When the operating torque of the inverter exceeds the setting of 9-05, the inverter will lower the output frequency following the deceleration time set by 9-06, and return to the normal operation frequency after the torque get steady.

- 9-08 : Electronic Motor Overload Protection Operation Mode:**
0000 : Enable Electronic Motor Overload Protection
0001 : Disable Electronic Motor Overload Protection
- 9-09 : Motor Type Selection:**
0000 : Electronic Motor Overload Protection Set for Non-Inverter Duty Motor
0001 : Electronic Motor Overload Protection Set for Inverter Duty Motor
- 9-10 : Motor Overload Protection Curve Selection:**
0000 : Constant Torque (OL=103%)(150%,1 minute)
0001 : Variable Torque (OL=113%)(123%,1 minute)
- 9-11 : Operation After Overload Protection is Activated:**
0000 : Coast-to-Stop After Overload Protection is Activated
0001 : Drive Will not Trip when Overload Protection is Activated (OL1)

Description of the thermal relay function:

1. 9-10 = 0000 : protect the general mechanical load, the load is less than 103% rated current, the motor continue to run. The load is larger than 150% rated current, the motor will run for 1 minute.(Refer to following curve(1).
 = 0001 : protect HVAC load(FAN、PUMP...so on) : the load is less than 113% rated current, the motor continue to run. The load is larger than 123% rated current, the motor will

run for 1 minute.

2. The heat sinking function will decline when the motor run at low speed. So the thermal relay action level will decline at the same time.(The curve 1 will change to curve 2).
3. 9-09 = 0000 : set 0-05 as the rated frequency of the serve motor.
 9-11 = 0000 : the inverter coast to stop as the thermal relay acts and flash OL1. Press the ‘reset’ or the external reset terminal to continue to run
 = 0001 : the inverter continues to run as the thermal relay acts and flash OL1. Till the current decline to 103% or 113%(determined by 9-10), OL1 will disappear.

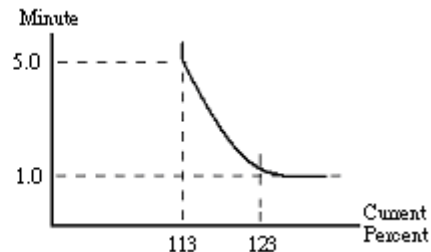
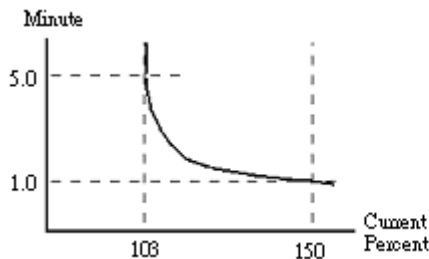

Electronic Motor Overload OL1 protection current and frequency

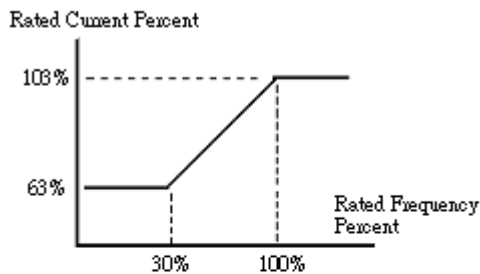

Non-Inverter Duty Motor OL1 Protection Curve
 OL=103% Start, 150%/1 Min.

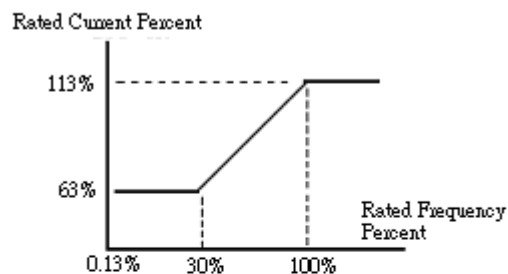

Non-Inverter Duty Motor OL1 Protection Curve
 OL=113% Start, 123%/1 Min.

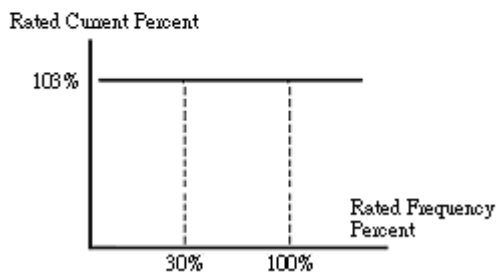

Inverter Duty Motor OL1 Protection Curve
 OL=103% Start, 150%/1 Min.

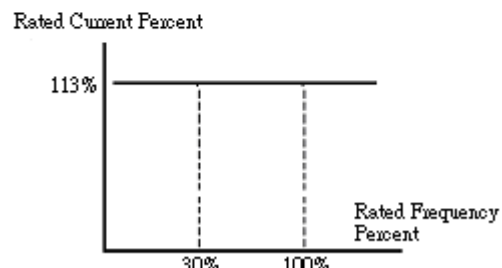

Inverter Duty Motor OL1 Protection Curve
 OL=113% Start, 123%/1 Min.

9-12 : Over Torque Detection Selection:

- = 0000 : Disable Over Torque Operation
- = 0001 : Enable Over Torque Operation Only if at Set Frequency
- = 0002 : Enable Over Torque Operation while the Drive is in Run Mode

9-13 : Operation After Over Torque Detection is Activated:

- = 0000 : Drive will Continue to Operate After Over Torque is Activated
- = 0001 : Coast-to-Stop After Over Torque is Activated

9-14 : Over Torque Threshold Level (%) : 30-200%

9-15 : Over Torque Activation Delay Time (s) : 0.0-25.0

The over torque is defined as: the output torque is inside parameter 9-15, the voltage level(the inverter rated torque is 100%) is over 9-14 parameter.

9-13 = 0000 : If there is over torque, the inverter can continue to run and flashes OL3 till the output

torque is less than the 9-14 setting value.

= 0001 : If there is over torque, the inverter coasts to stop and flashes OL3. it is necessary to press 'RESET' or external terminal to continue to run.

Parameter8-02,03(Multifunction output terminal) = 05, the output terminal is output over torque signal.

※Note: Over torque output signal will be output as the parameter 9-12=0001or 0002 when the level and time are over the range.

Parameter Group 10 – Volts /Hz Pattern Operation Mode

V/F PATTERN Selection

10-0 : V/F PATTERN Selection	= 0 – 18
10-1 : Torque boost gain(V/F pattern modulation)%	= 0.0 – 30.0%
10-2 : Motor no load current(Amps AC)	-----
10-3 : Motor rated slip compensation(%)	= 0.0 – 100.0%
10-4 : Max output frequency(HZ)	= 0.20 – 650.0Hz
10-5 : Max output frequency voltage ratio(%)	= 0.0 – 100.0%
10-6 : Medium frequency(HZ)	= 0.10 –650.0Hz
10-7 : Medium output frequency voltage ratio (%)	= 0.0 – 100.0%
10-8 : Min output frequency(HZ)	= 0.10 –650.0Hz
10-9 : Min output frequency voltage ratio (%)	= 0.0 – 100.0%

1. 10-0=18, set the V/F pattern freely complying with 10-4~10-9 (Refer to following diagram)

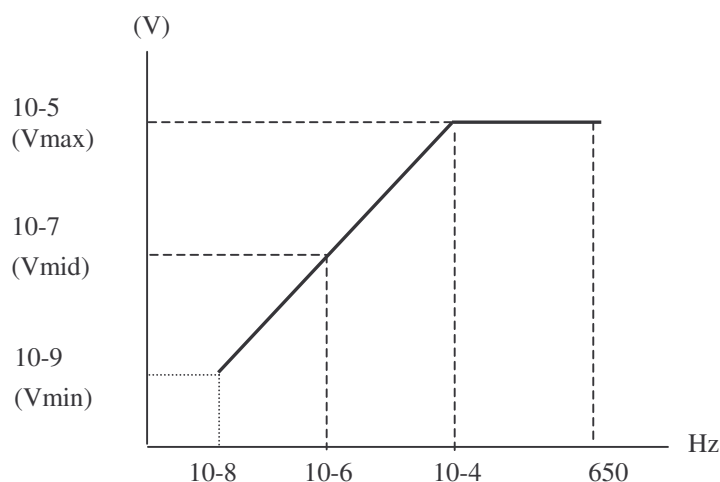

2. 10-0 = 0 – 17 V / F Pattern (Refer to following list).

type	Function	10-0	V/F pattern	type	Function	10-0	V/F pattern		
50 Hz	General Use	0		60 Hz	General Use	9			
		High start torque	1				High start torque	10	
			2					11	
	3				12				
	Decreasing torque	4			Decreasing torque	13			
		5				14			
	Constant torque	6			Constant torque	15			
		7				16			
		8				17			

10-0	B	C
0 / 9	50.0%	1.0%
1 / 10	60.0%	1.0%
2 / 11	65.0%	1.0%
3 / 12	70.0%	1.0%
4 / 13	40.0%	1.0%
5 / 14	35.0%	1.0%
6 / 15	45.0%	1.0%
7 / 16	55.0%	1.0%
8 / 17	65.0%	1.0%

3. The inverter will output the value that B, C voltage (refer to 10-0) plus 10-1 V/F pattern setting. And the start torque will be raised.

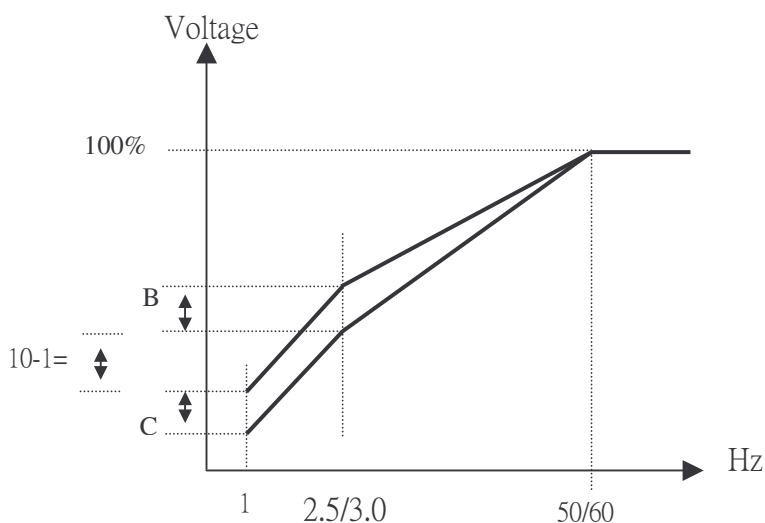

※Note: 10-1=0, Torque boost function is invalid

4. When the induction motor is in running, there must be slip due to the load. It is necessary to boost to improve the precision of the speed.

$$\text{Slip frequency boost} = \frac{\text{Output Current}-(10-2)}{(0-02)-(10-2)} \times (10-3) \quad \text{Note : } 0-02=\text{motor rated current}$$

10-2=motor no load current

$$10-3 \text{ rough value} = \frac{\text{Motor synchronization speed} - \text{Rated speed}}{\text{Motor synchronization speed}}$$

↑
Marked on the motor nameplate

$$\text{Motor synchronization speed (RPM)} = \frac{120}{\text{Motor Poles}} \times \text{Motor rated frequency (50Hz or 60Hz)}$$

eg: 4 Poles · 60Hz induction motor synchronization speed = $\frac{120}{4} \times 60 = 1800 \text{ RPM}$

※Note: Motor no load current(10-2) differs with the inverter capacities (15-0) (Refer to 0-02 note) , It should be regulated according to the actual condition.

Parameter group 11 - PID operation mode

11-0 : PID Operation Selection

0000: PID disable

0001: PID enable (Deviation is D-controlled)

0002: PID Feedback D-controlled

0003: PID D Reverse characteristic controlled

0004: PID Feedback D characteristic controlled

0005: PID, Frequency command + D controlled

0006: PID, Frequency command + Feedback D controlled

0007: PID, Frequency Command + D reverse Characteristic controlled.

0008: PID, Frequency Command + Feedback D reverse Characteristic controlled.

11-0 =1, D is the deviation of (target value – detected value) in the unit time (11-4).

=2, D is the deviation of the detected values in unit time (11-4).

=3, D is the deviation of (target value – detected value) in the unit time (11-4). If the deviation is positive, the output frequency decreases, vice versa.

=4, D is the deviation of detected value in unit time (11-4). When the deviation is positive, the frequency decreases, vice versa.

=5, D is equal to the deviation of (target value – detected value) in unit time (11-4) +Frequency command.

=6, D is equal to the deviation of detected values in unit time + Frequency command.

=7, D is equal to the deviation of (target value – detected value) in unit time +Frequency command. If the deviation is positive, the output frequency decreases, vice versa.

=8, D is equal to the deviation of detected values in unit time + Frequency command. When the deviation is positive, the frequency decreases, vice versa.

11-1 : Feedback Calibration Gain(%) : 0.00 - 10.00

11-1 is the calibration gain. Deviation = (target value – detected value) × 11-1

11-2 : Proportion Gain(%) : 0.00 - 10.00

11-2 : Proportion gain for P control.

11-3 : Integrate Time (s) : 0.0 - 100.0

11-3 : Integrate time for I control

11-4 : Differential Time (s) : 0.00 - 10.00

11-4 : Differential time for D control

11-5: PID Offset : 0000 : Positive Direction

0001 :Negative Direction

11-6: PID Offset Adjust (%) : -109% ~ +109%

11-5/11-6 : PID the calculated result pluses 11-6 (the sign of 11-6 is determined by 11-5).

11-7 : Output Lag Filter Time (s) : 0.0 - 2.5

11-7 : update time for output frequency.

※Note: PID Function is available for controlling the output flow, external fan flow and temperature.

The controlling flow is as follow:

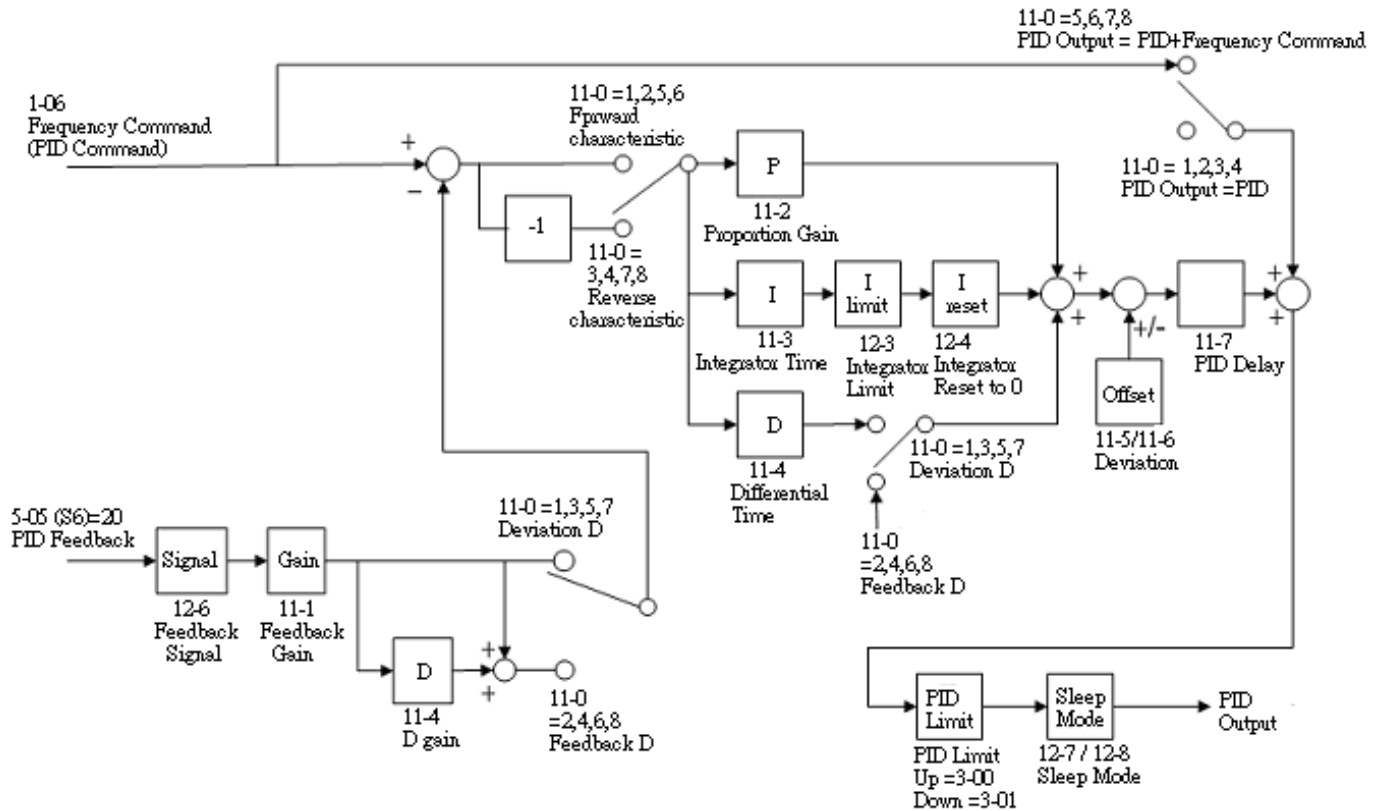

1. Performing PID control, set 5-05=20, AI2 (S6) on TM2 as PID feedback signal.
2. The target value of above diagram is the 1-06 input frequency.
3. There are two ways to see the PID feedback signal, one is using the Keypad switch display (4-06 must be setting as 1), the other is using analog output FM+ (8-00 must be setting as 5).

Parameter Group 12 - PID "Limits" and "Out of Range" Mode

12-0 : Feedback Loss Detection Mode: 0000:Disable

0001:Enable – Drive Continues to Operate After Feedback Loss

0002:Enable – Drive “STOPS” After Feedback Loss

12-0= 0 : Disable; 12-0= 1 : detect to run and display PDER ; 12-0= 2 : detect to stop and display PDER。

12-1 : Feedback Loss Detection Mode (%) : 0 - 100

12-1 is the level for signal loss. Deviation = Command value – Feedback value. While the deviation is larger than the loss level, the feedback signal is lost.

12-2 : Feedback Loss Detection Delay Time (s) : 0.0 -25.5

12-2 : the action lay time as the feedback signal lost.

12-3 : Integrate Limit Value (%) : 0 - 109

12-3 : the Limiter to prevent PID saturating.

12-4 : Integrator Reset to 0 when Feedback Signal Equals the Intended Value:

0000:Disable

0001:1 second

0030: 30 seconds

12-4=0 : As PID feedback value reaches the command value, the integrator will not be reset to 0.

12-4=1~30 : As PID feedback value reaches the target value, reset to 0 in 1~30 seconds and inverter stops output. The inverter will output again as the feedback value differs from the target value.

12-5 : Allowable Integration Error Margin (Unit Value) (1 Unit = 1/8192) : 0 - 100

12-5=0 ~ 100% unit value : restart the tolerance after the integrator reset to 0.

12-6 : PID Feedback Signal : 0000: 0~10V or 0~20mA

0001: 2~10V or 4~20mA

12-6 : Feedback signal selection, 12-6=0 : 0~10V or 0~20mA (signal V or I decide to SW2)

12-6=1 : 2~10V or 4~20mA(signal V or I decide to SW2)

12-7, 12-8 : PID Sleep Mode

PID SLEEP MODE:

11-0=1(PID Enable)

5-05=20(PID FEEDBACK Enable)

1-06=PID setting frequency source (Target Value)

12-7 Set the frequency for sleep start, Unit: HZ

12-8 Set the Time for sleep delay, Unit: sec

When PID output frequency is less than the frequency for sleep start and the reaches the time of sleep delay, the inverter will decelerate to 0 and enter PID sleep mode.

When PID output frequency is larger than the frequency for sleep start the inverter will be awaked and enter PID awake mode. The time diagram is as follow:

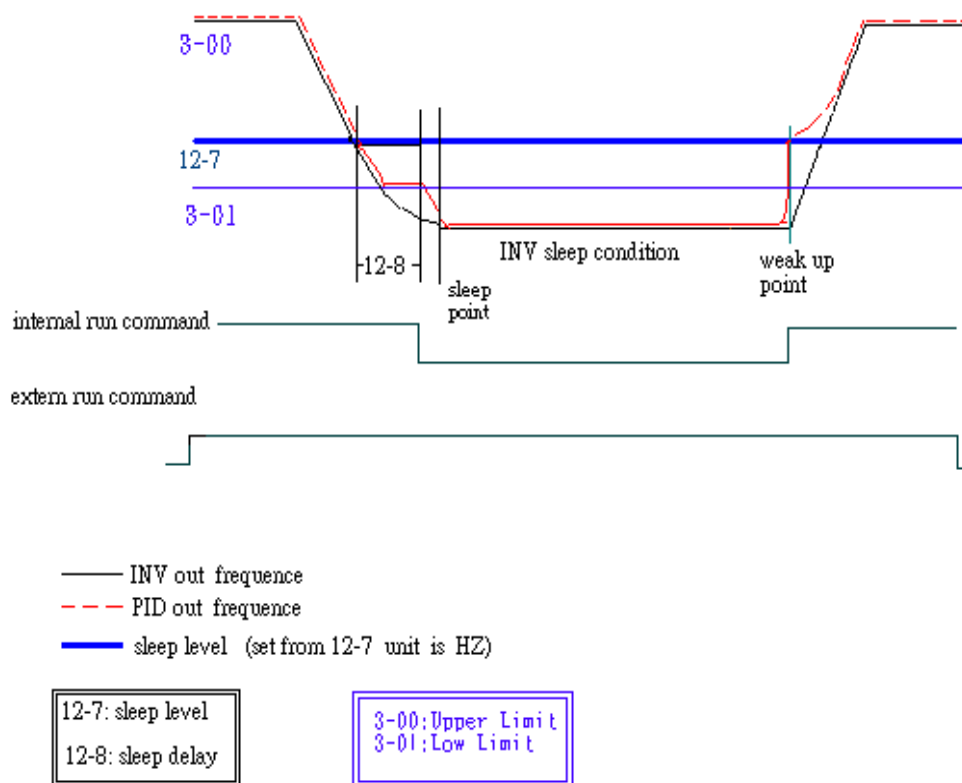

Parameter Group 13 - Communication mode

13-0 : Assigned Communication Station Number : 1 - 254

13-0: to set the communication station codes which are suitable for driving more than one inverters situations.

13-1 : Baud Rate setting (bps) :

- 0000: 4800
- 0001: 9600
- 0002: 19200
- 0003: 38400

13-2 : Stop Bit Selection :

- 0000: 1 stop bit
- 0001: 2 stop bit

13-3 : Parity Selection :

- 0000 : no parity
- 0001 : even parity
- 0002 : odd parity

13-4 : Data Format Selection :

- 0000 :8 bit data
- 0001 :7 bit data

1.RS-485 Communication :

(1)1 vs 1 Controlling : to control one inverter by a PC or PLC or controller.(set 13-0 = 1~254)

(2) 1 vs more Controlling : to control more than one inverters by PC or PLC or Controller (The max number of inverter could be 254. set 13-0 = 1~254), when the inverter receives the communication station code = 0, the communication controlling is acceptable regardless the setting value of 13-0.

2. RS-232 communication: (RS232 interface is required)

1 vs 1 controlling: to control one inverter by a PC or PLC or controller. (Set 13-0 = 1~254)

※Note:

- The BAUD RATE (13-1) of PC (or PLC or Controller) and the one of the inverter should be set as the same. Communication format (13-2/13-3/13-4) should be set as the same.
- The inverter will confirm the parameter efficient as PC modifies the parameter of the inverter.
- Please refer to the VAT200 Communication PROTOCOL.

Parameter Group 14 - Auto Tuning

14-0 : Stator Resistance(Ohms) Gain

14-1 : Rotator Resistance(Ohms) Gain

14-2 : Equivalent Inductance(mH) Gain

14-3 : Magnetized Current(Amps AC) Gain

14-4 : Ferrit Loss Conduction (gm) Gain

- If 0-00=0 or 1(vector mode) is selected, as power ON, set 0-06=1, the motor will run as the inverter performs auto tuning. As the motor stop, it means that auto tuning finished. The inverter will write the internal parameter of the motor to 14-0~ 14-4, and auto reset the 0-06 as 0.
- Auto tuning must be carried out as long as the motor changed. If the internal parameters is known already, they can be input to 14-0~14-4 directly.
- 0-06=1 to perform auto tuning, after finished, 0-06 auto reset to 0, the Keypad displays END.
- The parameter group only affect the current vector.

Parameter Group 15 - Operation Status and Function Reset

15-0 : Drive Horsepower Code

15-0	Inverter Model
2P5	U20_N00K4
201	U20_N00K7
202	U20_N01K5
203	U20_N02K2
205	U203N04K0
208	U203N05K5
210	U203N07K5

15-0	Inverter Model
401	U203X00K7
402	U203X01K5
403	U203X02K2
405	U203X04K0
408	U203X05K5
410	U203X07K5
415	U203X11K0
420	U203X15K0
425	U203X18K5
430	U203X22K0
440	U203X30K0
450	U203X37K0
460	U203X45K0
475	U203X55K0

15-1 : Software Version**15-2 : Fault Jog (Latest 3 times)**

1. When the inverter doesn't work normally, the former fault log stored in 2.xxxx will be transferred to 3.xxxx, then, the one in 1.xxxx to 2.xxxx. The present fault will be stored in the blank 1.xxxx. Thusly, the fault stored in 3.xxxx is the earliest one of the three, while the one 1.xxxx is the latest.
2. Enter 15-2, the fault 1.xxxx will be displayed firstly, press ▲, you can read 2.xxxx→3.xxx→1.xxx, whereas ▼, the order is 3.xxx→2.xxx→1.xxx→3.xxx.
3. Enter 15-2, the three fault log will be cleared as the reset key is pressed. The log content will be changed to 1.--- , 2.--- , 3.---
4. E.g. if the fault log content is '1.OCC' which indicates the latest fault is OC-C, and so on.

15-3 : Accumulated Operation Time 1 (Hours): 0 – 9999**15-4 : Accumulated Operation Time 2 (Hours X 10000): 0 - 27****15-5 : Accumulated Operation Time Mode: 0000: Power on time****0001: Operation time**

1. When the operation time is to 9999 as the operation duration 1 is set. The next hour will be carried to operation duration 2. Meanwhile, the recorded value will be cleared to 0000, and the record value of operation duration 2 will be 01.
2. Description of operation time selection:

Preset value	Description
0	Power on, count the accumulated time.
1	Inverter operation, count the accumulated operation time

15-6 : Reset the factory setting: 1110: Reset the 50Hz factory setting**1111: Reset the 60Hz factory setting****1112: Reset PLC program**

As 15-6 is set as 1111, the parameter will be reset to factory setting. The max output voltage will comply with the voltage and frequency (0-01/0-05) on the nameplate of the motor. The output frequency is 60Hz if the upper frequency limit is not set.

※Note:

Motor parameters (14-0~14-4) will be modified under V/F control mode when reset factory setting. On the contrary, motor parameters (14-0~14-4) will not be modified under vector control mode when reset factory setting.

4.5 Specification Description on Built-in PLC Function

7300CV has Built-in simple PLC function, user can download Ladder Diagram from PC (Windows base software) or PDA (WinCE base software) very friendly.

4.5.1 Basic Instruction

				P			NO / NC
Input Instruction					I	i	I1~I7 / i1~i7
Output Instruction	Q	Q	Q	Q	Q	q	Q1~Q2 / q1~q2
Auxiliary Instruction	M	M	M	M	M	m	M1~MF / m1~mF
Special Register							V1~V7
Counter Instruction	C				C	c	C1~C4 / c1~c4
Timer Instruction	T				T	t	T1~T8 / t1~t8
Analog Comparing Instruction	G				G	g	G1~G4 / g1~g4
Encoder Comparing Instruction	H				H	h	H1~H4 / h1~h4
Operation Instruction	F				F	f	F1~F8 / f1~f8

Description for Special Register

V1: Setting Frequency	Range: 0.1~650.0Hz
V2: Operation Frequency	Range: 0.1~650.0Hz
V3: AIN Input value	Range: 0~1000
V4: S6 Input Value	Range: 0~1000
V5: Keypad VR Input Value	Range: 0~1000
V6: Operation Current	Range: 0.1~999.9A
V7: Torque Value	Range: 0.1~200.0%

	Upper differential	Lower differential	Other Instruction Symbol
Differential Instruction	D	d	
SET Instruction			
RESET Instruction			
P Instruction			P

Open circuit (On status)	“ ”	
Short circuit (Off status)	“ -- ”	

Connection symbol	Description
—	Connecting left and right Components
⊥	Connecting left, right and upper Components
⊕	Connecting left, right, upper and lower Components
⊓	Connecting left, right and lower Components

4.5.2 Function of Basic Instruction

- Function D (d) Command

Sample 1: I1-D —[Q1

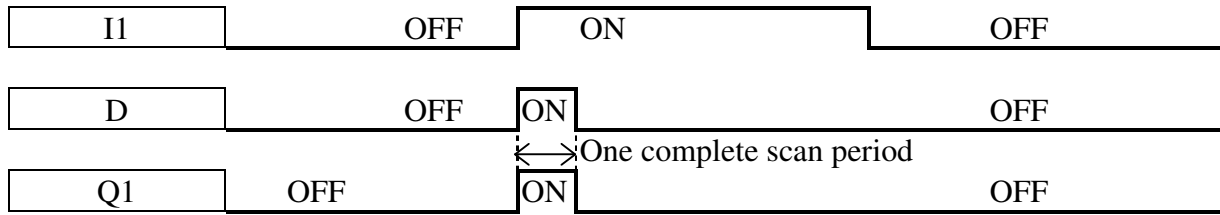

Sample 2: i1-d —[Q1

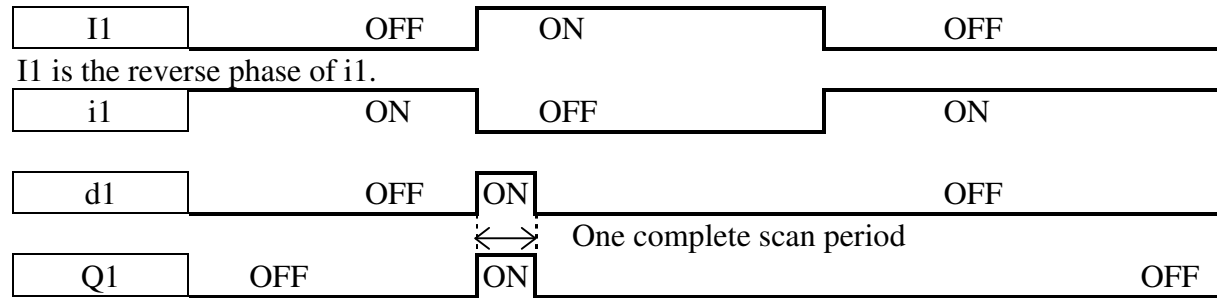

- NORMAL (- [) Output

I1 — [Q1

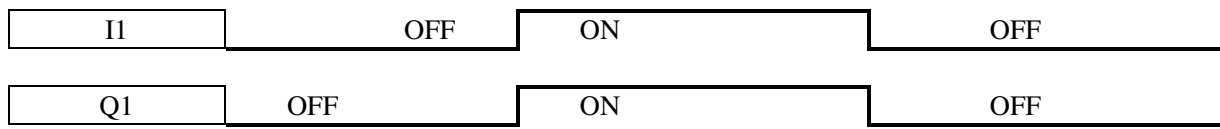

- ⊙ SET (▲) Output

I1 — ▲Q1

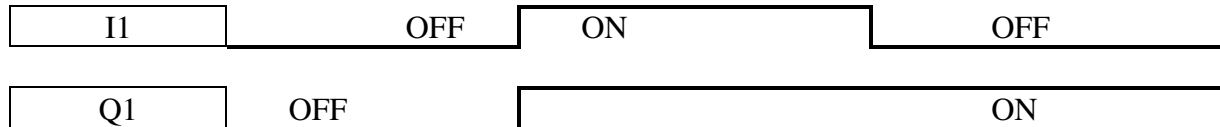

- RESET (▼) Output

I1 — ▼Q1



- P Output

i1 — PQ1

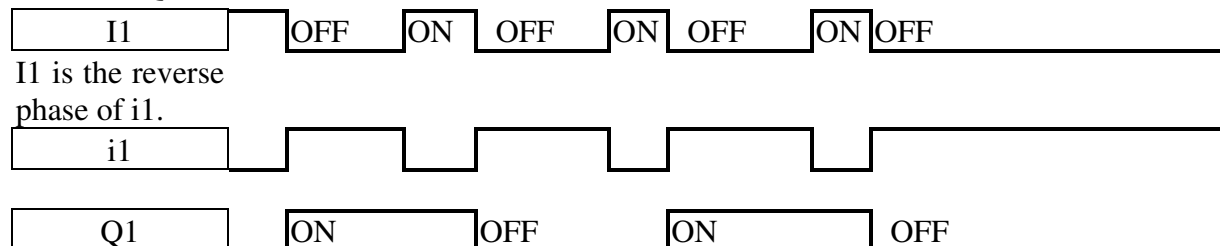

Sample:

Input under the Ladder Program Mode

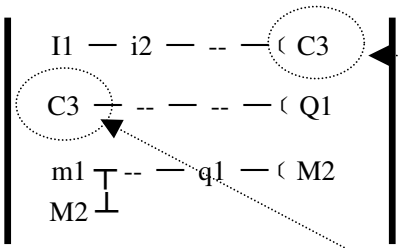

The ON/OFF of C3 input count pulse is controlled by I1 and i2.

Input under the Function Program Mode

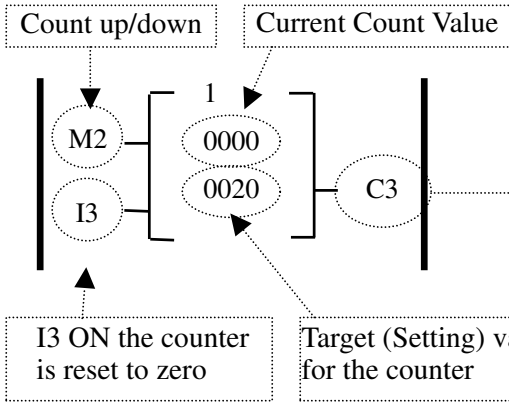

When the target value is reached, C3 =ON.
The input point C3 in the ladder program should be ON.

(2) Counter Mode 2

① = 2

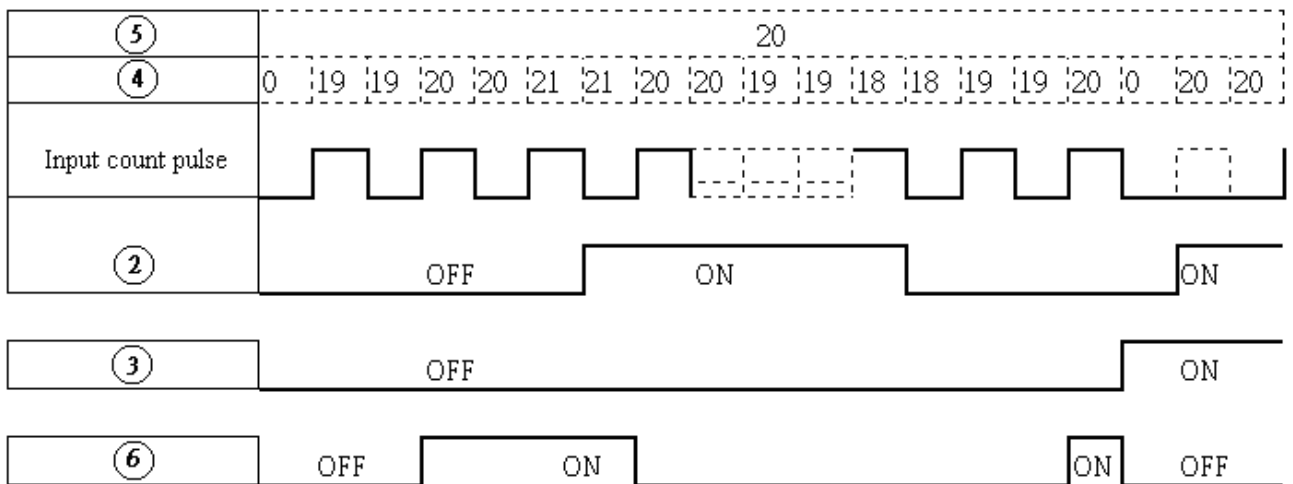

※Note:

Under this Mode, the counting preset value appeared will be greater than 20, unlike the Mode 1 in which the value is locked at 20.

- (3) The counter Mode 3 is similar to the counter Mode 1 except that the former can memory the recorded value after the power is cut off and continued counting when the power is turned on at the next time.
- (4) The counter Mode 4 is similar to the counter Mode 2 except that the former can memory the recorded value after the power is cut off and continued counting when the power is turned on at the next time.

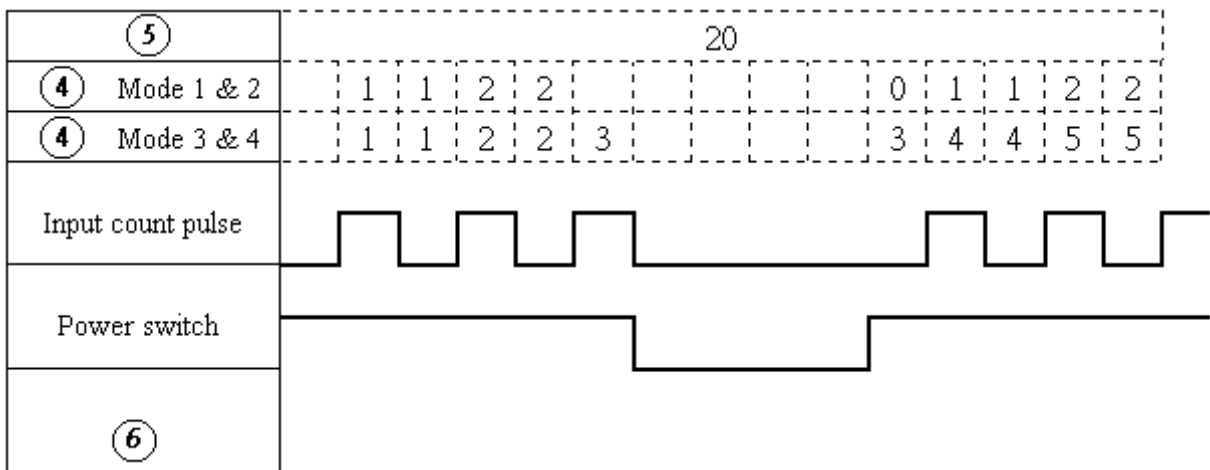

□ Timer

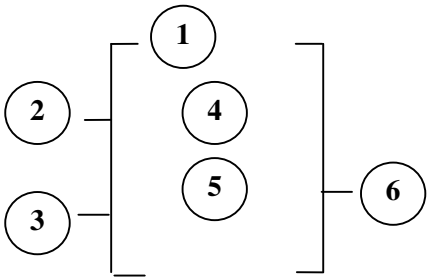

Symbol	Description
①	Timing Mode (1-7)
②	Timing unit 1: 0.0 – 999.9 sec 2: 0 – 9999 sec 3: 0 – 9999 min
③	Use (I1 ~ f8) to RESET the timing value. ON: the counter is reset to zero and ⑥ OFF OFF: the counter continues to count
④	Preset Timing Value
⑤	Target (setting) Timing Values
⑥	The code of the Timer (T1 ~T8 total: 8 groups).

(1) Timer Mode 1 (ON-Delay A Mode)

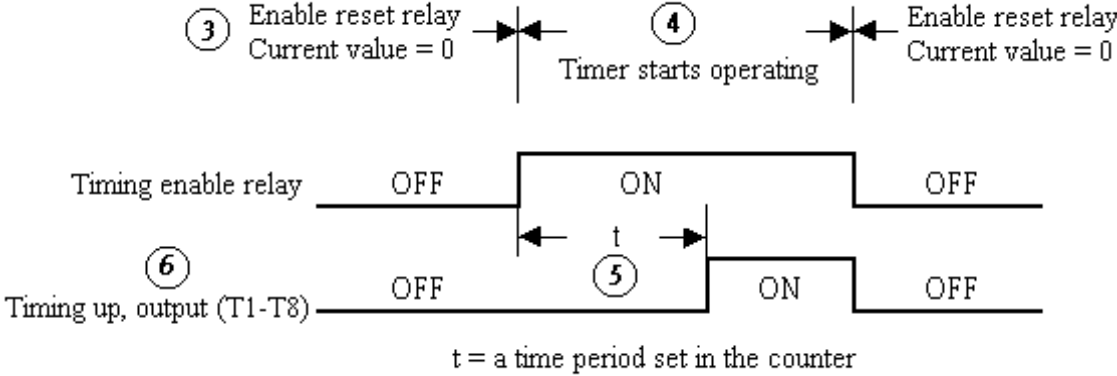

Sample:

Input under the Ladder Program Mode

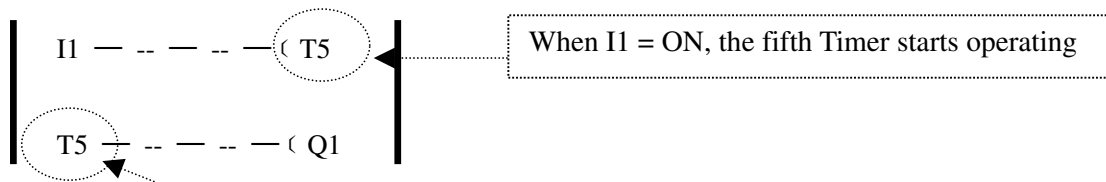

Input under the Function Program Mode

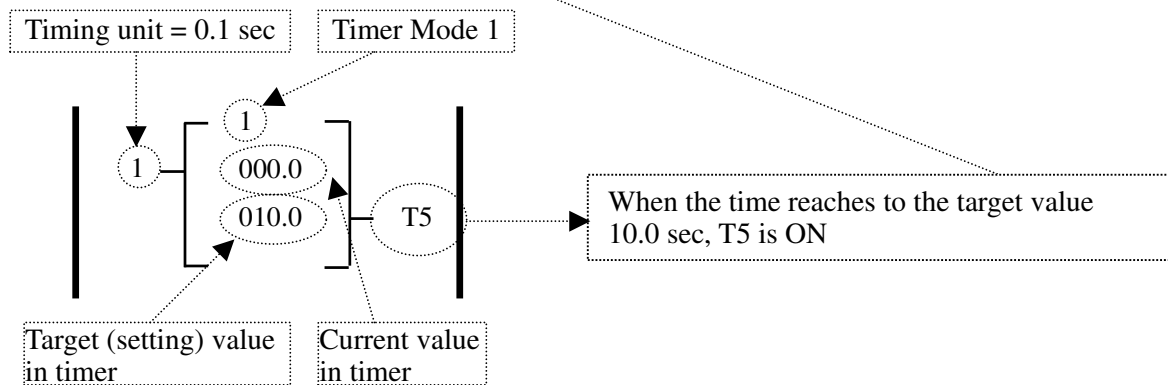

(2) Timer Mode 2 (ON-Delay B Mode)

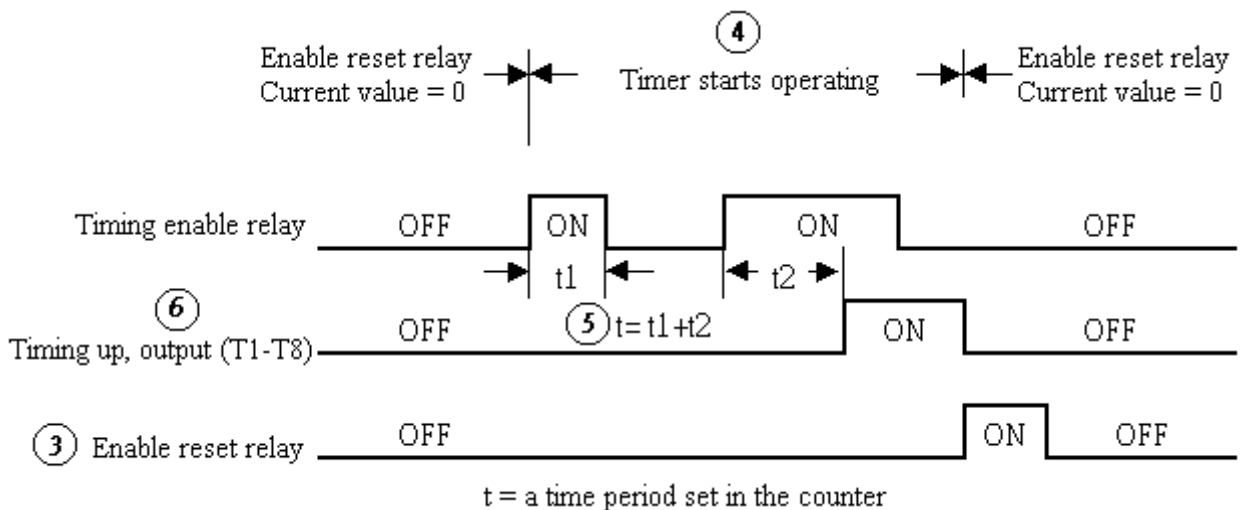

(3) Timer Mode 3 (OFF-Delay A Mode)

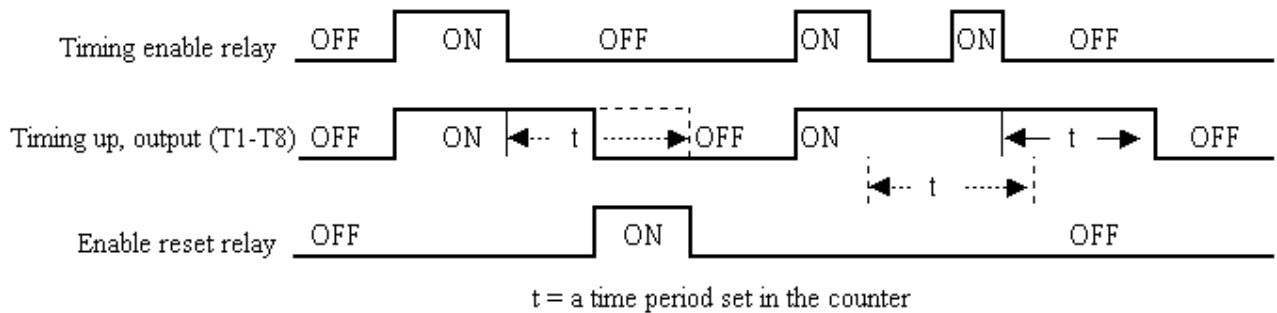
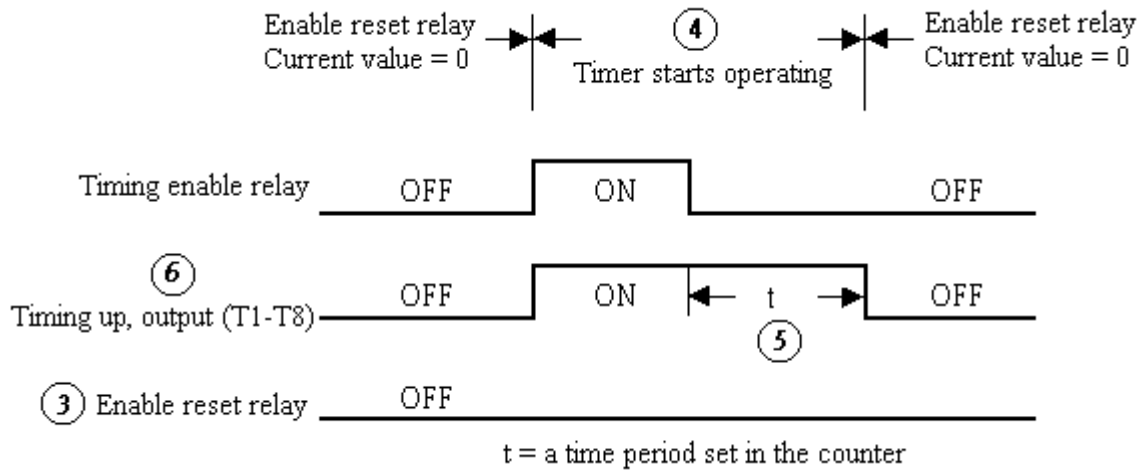

(4) Timer Mode 4 (OFF-Delay B Mode)

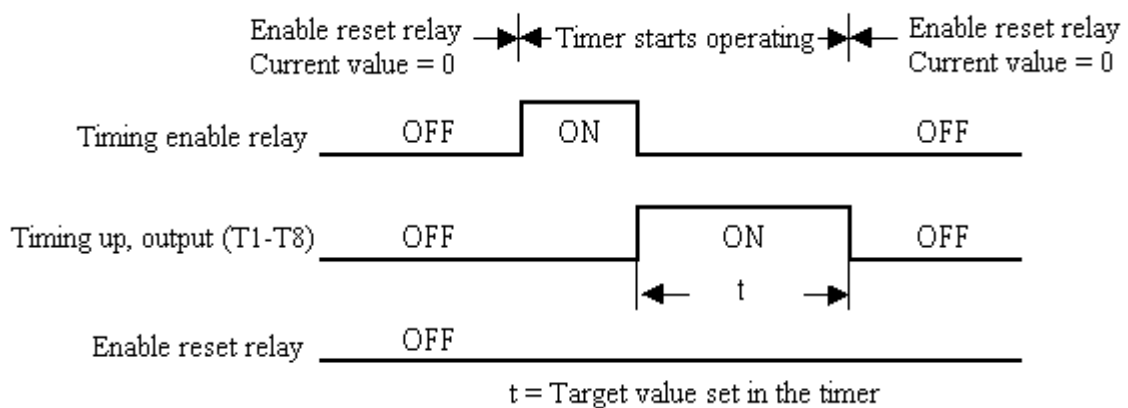

(5) Timer Mode 5 (Flash A Mode)

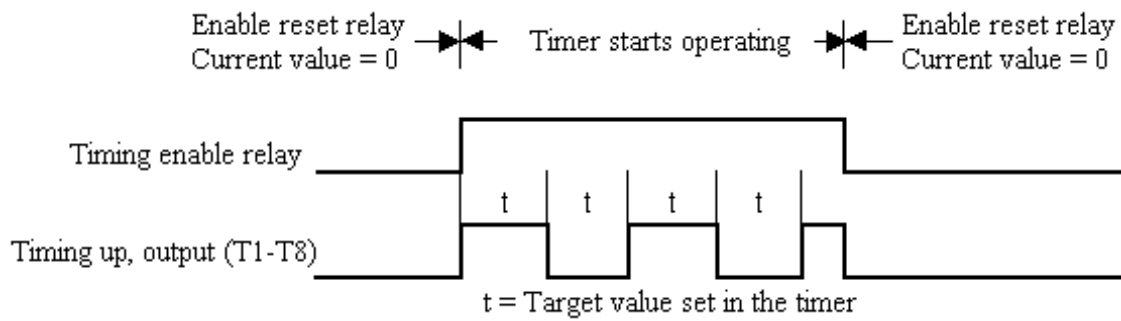

(6) Timer Mode 6 (Flash B Mode)

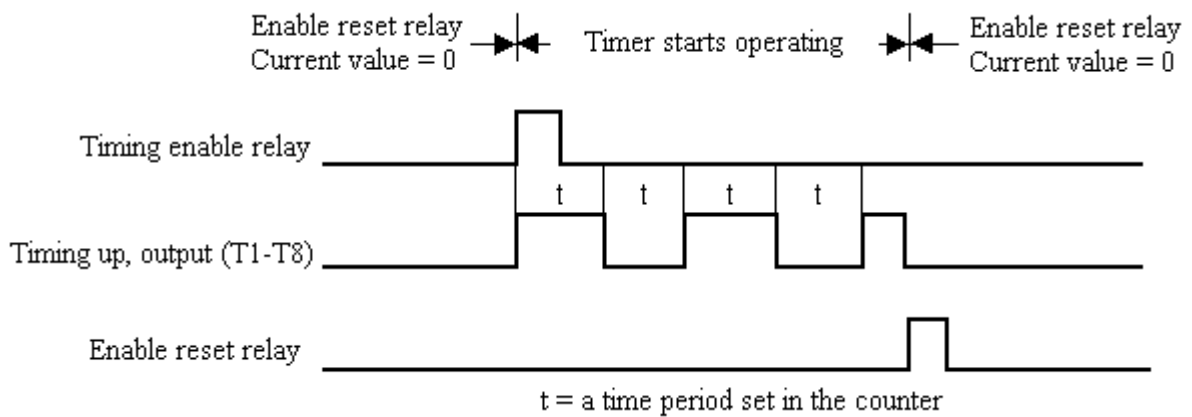

(7) Timer Mode 7 (Flash C Mode)

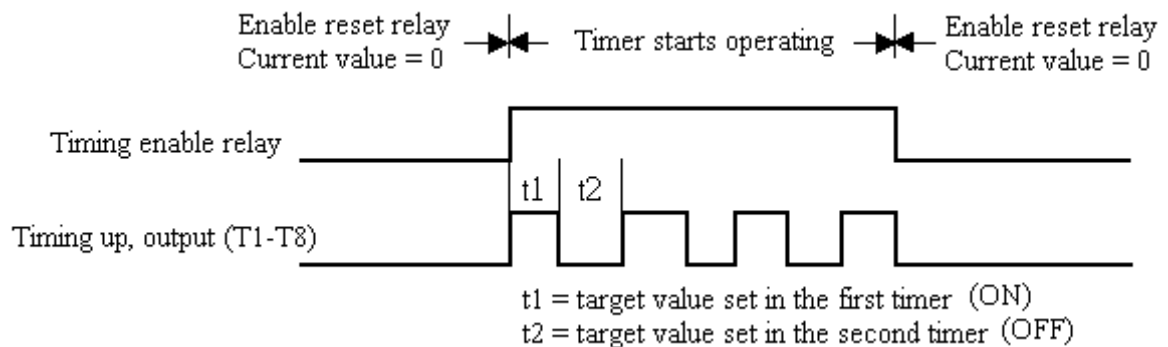

□ Analog comparator

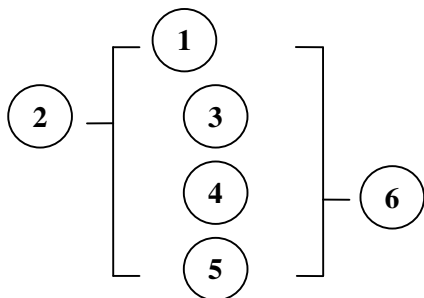

Symbol	Description
①	Analog comparison mode (1-3)
②	Selection of the input comparison value
③	Analog input value
④	Setting reference comparison value (upper limit)
⑤	Setting reference comparison value (lower limit)
⑥	Output terminals of analog comparator (G1-G4)

□ Analog Comparison Mode (1-3)

- (1) Analog comparator mode 1 (③ ≤ ⑤, ⑥ ON)
- (2) Analog comparator mode 2 (③ ≥ ④, ⑥ ON)
- (3) Analog comparator mode 3 (⑤ ≤ ③ ≤ ④, ⑥ ON)

Selection of the input comparison value (V1-V7)

- (1) The input comparison value =V1: Setting Frequency
- (2) The input comparison value =V2: Operation Frequency
- (3) The input comparison value =V3: AIN Input Value
- (4) The input comparison value =V4: AI2 Input Value
- (5) The input comparison value =V5: Keypad VR input Value
- (6) The input comparison value =V6: Operation Current
- (7) The input comparison value =V7: Torque Value

□ Encoder input Comparing Instruction

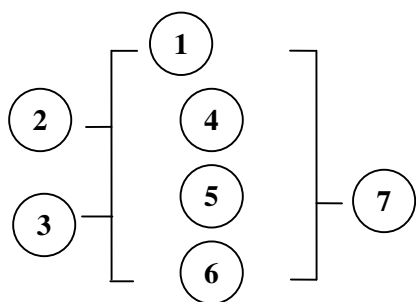

Symbol	Description
①	Encoder control mode (1-2)
②	Use (I1 ~ f8) to set counting up or counting down OFF: counting up (0, 1, 2, 3, 4...) ON: counting down (...3, 2, 1, 0)
③	Use (I1~f8) to Reset counting value.
④	A1, Encoder Input Value/Encoder dividing ratio(Ⓔ)
⑤	A2, Setting comparing value
⑥	C, Encoder dividing ratio
⑦	Encoder comparing output terminal, H1~H4

(1) Control Mode 1

Encoder Comparing Function: A1/C□A2 Comparing Output

(2) Control Mode 2

Encoder Comparing Function: A1/C□A2 Comparing Output

※Comparison Enable/ Disable of the Encoder input value is determined by the Ladder Program ON/OFF.

□ Running Instruction

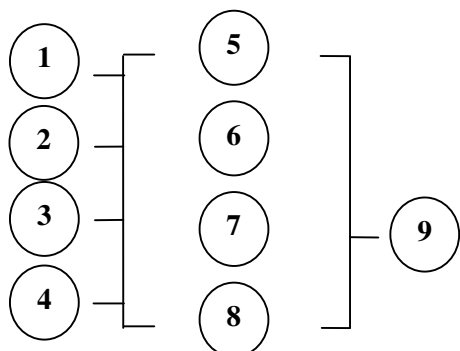

Symbol	Description
①	Running mode could be set via I1~f8 OFF: (FWD) ON: (REV)
②	Segment Speed could be set via I1~f8 OFF: Operating at the frequency set on ⑦ ON: Operating at the frequency set on ⑧
③	Select constant or V3, V5 for Setting Frequency
④	Select constant or V3, V5 for Preset Speed
⑤	Acceleration Time
⑥	Deceleration Time
⑦	Setting Frequency (Could be a constant or V3, V5)
⑧	Segment Speed (Could be a constant or V3, V5)
⑨	Instruction code of operation (F1~F8, Total: 8 Groups)

Sample:

Input under the Ladder Program Mode

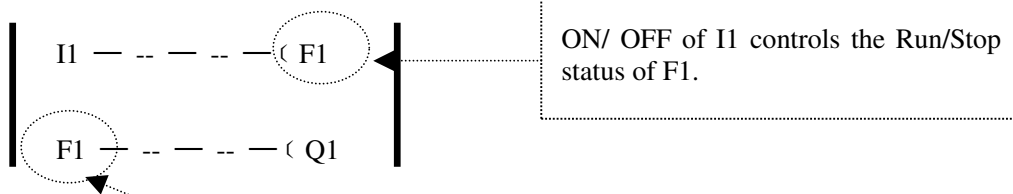

Input under the Function Program Mode

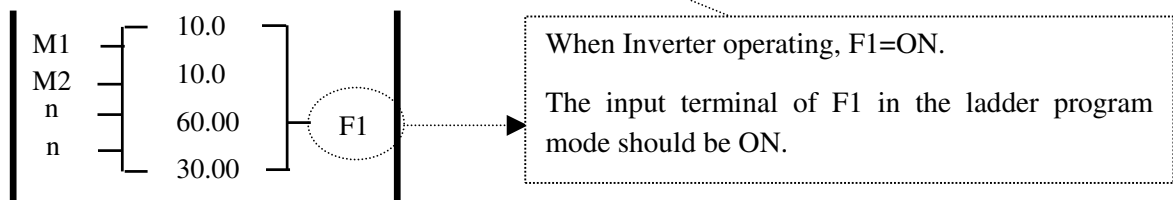

Chapter 5 Troubleshooting and maintenance

5.1. Error display and remedy

5.1.1. Errors which can not be recovered manually

Display	Error	Cause	Remedy
CPF	Program problem	External noise interference	Connect a parallel RC burst absorber across the magnetizing coil of the magnetic contactor that causes interference
EPR	EEPROM problem	Faulty EEPROM	Replace EEPROM
@ -OV-	Voltage too high during stop	Detection circuit malfunction	Send the inverter back for repairing
@ -LV-	Voltage too low during stop	<ol style="list-style-type: none"> 1. Power voltage too low 2. Restraining resistor or fuse burnt out. 3. Detection circuit malfunctions 	<ol style="list-style-type: none"> 1. Check if the power voltage was correct or not 2. Replace the restraining resistor or the fuse 3. Send the inverter back for repairing
@ -OH-	The inverter is overheated during stop	<ol style="list-style-type: none"> 1. Detection circuit malfunctions 2. Ambient temperature too high or bad ventilation 	<ol style="list-style-type: none"> 1. Send the inverter back for repairing 2. Improve ventilation conditions
CTER	Current Sensor detecting error	Current sensor error or circuit malfunctions	Send the inverter back for repairing

※ Note : “@ ” the Failure contact does not function.

Errors which can be recovered manually and automatically

Display	Error	Cause	Remedy
OC-S	Over current at start	<ol style="list-style-type: none"> 1. the motor wind and enclosure short circuit 2. the motor contacts and earth short circuit 3. the IGBT module ruined 	<ol style="list-style-type: none"> 1. inspect the motor 2. inspect the wire 3. replace the transistor module
OC-D	Over-current at deceleration	The preset deceleration time is too short.	Set a longer deceleration time
OC-A	Over-current at acceleration	<ol style="list-style-type: none"> 1. Acceleration time too short 2. The capacity of the motor higher than the capacity of the inverter 3. Short circuit between the motor coil and the shell 4. Short circuit between motor wiring and earth 5. IGBT module damaged 	<ol style="list-style-type: none"> 1. Set a longer acceleration time 2. Replace a inverter with the same capacity as that of the motor 3. Check the motor 4. Check the wiring 5. Replace the IGBT module
OC-C	Over-current at fixed speed	<ol style="list-style-type: none"> 1. Transient load change 2. Transient power change 	<ol style="list-style-type: none"> 1. Increase the capacity of the inverter 2. Rerun parameter auto tuning (0-06 = 1) 3. Reduce stator resistance (14-0) if the above remedies are helpless
OV-C	Voltage too high during operation/ deceleration	<ol style="list-style-type: none"> 1. Deceleration time setting too short or large load inertia 2. Power voltage varies widely 	<ol style="list-style-type: none"> 1. Set a longer deceleration time 2. Add a brake resistor or brake module 3. Add a reactor at the power input side 4. Increase inverter capacity
Err4	Illegal interrupt of CPU	Outside noise interference	Send back to repair if it happens many times
OVSP	Over speed during operating	<ol style="list-style-type: none"> 1. Motor load too big or Inverter capacity too small 2. Motor parameter error (vector mode) 3. The gain is too big during vector mode operating 4. The Current detect circuit fault 	<ol style="list-style-type: none"> 1. Increase acceleration / deceleration time (3-02/3-03) 2. Input correct motor Parameter 3. Change stator Resistance gain and Rotator resistance gain (14-0/14-1), suggest that decrease 50~100, until 0 4. Send back to GE

Errors which can be recovered manually

Display	Error	Cause	Remedy
OC	Over-current during stop	<ol style="list-style-type: none"> 1. Detection circuit malfunctions 2. Bad connection for CT signal cable 	<ol style="list-style-type: none"> 1. Check the noise between Power line and motor line 2. Send the inverter back for repairing
OL1	Motor overload	<ol style="list-style-type: none"> 1. Heavy load 2. Inappropriate settings of 0-02, 9-08~11 	<ol style="list-style-type: none"> 1. Increase the motor capacity 2. set 0-02, 9-08~11 properly
OL2	Inverter overload	Heavy Load	Increase the inverter capacity
OL3	Over torque	<ol style="list-style-type: none"> 1. Heavy Load 2. Insufficient settings of 9-14, 9-15 	<ol style="list-style-type: none"> 1. Increase the inverter capacity 2. set 9-14, 9-15 properly
LV-C	Voltage too low during operation	<ol style="list-style-type: none"> 1. Power voltage too low 2. Power voltage varies widely 	<ol style="list-style-type: none"> 1. Improve power quality or increase the value of 2-01 2. Set a longer acceleration time 3. Increase inverter capacitor 4. Add a reactor at the power input side
OH-C	Heatsink temperature too High during operation	<ol style="list-style-type: none"> 1. Heavy load 2. Ambient temperature too high or bad ventilation 	<ol style="list-style-type: none"> 1. Check if there are any problems with the load 2. Increase inverter capacity 3. Improve ventilation conditions

5.1.2 Special conditions

Display	Error	Description
STP0	Zero speed stop	Happened when preset frequency <0.1Hz
STP1	Fail to start directly	<ol style="list-style-type: none"> 1. If the inverter is set as external terminal control mode (1-00=1) and direct start is disabled (2-04=0001), the inverter cannot be started and will flash STP1 when operation switch turned to ON after applying power (refer to descriptions of 2-04). 2. Direct start is possible when 2-04=0001.
STP2	Keypad emergency stop	<ol style="list-style-type: none"> 1. If the inverter is set as external control mode (1-00=0001) and Stop key is enabled (1-03=0000), the inverter will stop according to the setting of 1-05 when Stop key is pressed. STP2 flashes after stop. Turn the operation switch to OFF and then ON again to restart the inverter. 2. If the inverter is in communication mode and Stop key is enabled (1-03=0000), the inverter will stop in the way set by 1-05 when Stop key is pressed during operation and then flashes STP2. The PC has to send a Stop command then a Run command to the inverter for it to be restarted. 3. Stop key cannot perform emergency stop when 1-03=0001
E.S.	External emergency stop	The inverter will ramp stop and then flash E.S., when input external emergency stop signal via the multifunctional input terminal (refer to descriptions of 5-00~5-06).
b.b.	External base block	The inverter stops immediately and then flashes b.b., when external base block is input through the multifunctional input terminal (refer to descriptions of 5-00~5-06).
ATER	Auto-tuning faults	<ol style="list-style-type: none"> 1. Motor data error resulting in for auto-tuning failure 2. Stop the inverter emergently during Auto-tuning
PDER	PID feedback loss	PID feedback loss detect

5.1.3 Operation errors

Display	Error	Cause	Remedy
LOC	Parameter and frequency reverse already locked	1.Attempt to modify frequency /parameter while 3-17>0000 2.Attempt to reverse while 1-02=0001	1.Set 3-17=0000 2. Set 1-02=0000
Err1	Key operation error	1.Press ▲ or ▼ while 1-06>0 or running at preset speed. 2.Attempt to modify the parameter can not be modified during operation (refer to the parameter list).	1.The ▲ or ▼ is available for modifying the parameter only when 1-06=0 2.Modify the parameter while STOP
Err2	Parameter setting error	1. 3-01 in the range of 3-13 ± 3-16 or 3-14 ± 3-16 or 3-15 ± 3-16 2. 3-00 ≤ 3-01 3.The setting error as performing Auto tuning(e.g. 1-00 ≠ 0, 1-06 ≠ 0)	1.Modify 3-13~3-15 or 3-16 2. 3-00 > 3-01 Set 1-00=0, 1-06=0 during Auto tuning
Err5	Modification of parameter is not available in communication	1.Issue a control command during communication disabled 2.Modify the function 13-1~13-4 during communication	1.Issue enable command before communication 2.Set the very parameter of the function before communication
Err6	Communication failed	1.Wiring error 2.Communication parameter setting error. 3.Sum-check error 4.Incorrect communication protocol	1.Check hardware and wiring 2.Check Function 13-1~13-4
Err7	Parameter conflict	1.Attempt to modify the function 15-0 or 15-7 2.Voltage and current detection circuit is abnormal	If Reset inverter is not available, please send the inverter back for repair
Err8	Factory setting error	When PLC is Running, Perform factory setting	Please perform factory setting before PLC stops.
EPr1	Parameter setting error copy unit failed	1.Set 3-18=1.2 without connecting copy unit. 2. Copy unit failed.	1.Modify 3-18 2.Replace copy unit
EPr2	Parameter not match	Copy the parameter to inverter to verify the parameter is not match.	1.Rewrite again 2.Replace copy unit

5.2 General troubleshooting

Status	Checking point	Remedy
Motor can not run	Is power applied to L1(L), L2, and L3(N) terminals (is the charging indicator lit)?	<ul style="list-style-type: none"> • Is the power applied? • Turn the power OFF and then ON again. • Make sure the power voltage is correct. • Make sure screws are secured firmly.
	Are there voltage across the output terminal T1, T2, and T3?	<ul style="list-style-type: none"> • Turn the power OFF and then ON again.
	Is overload causing the motor blocked?	<ul style="list-style-type: none"> • Reduce the load to let the motor running.
	Are there any abnormalities in the inverter?	<ul style="list-style-type: none"> • See error descriptions to check wiring and correct if necessary.
	Is forward or reverse running command issued?	
	Has analog frequency signal been input?	<ul style="list-style-type: none"> • Is analog frequency input signal wiring correct? • Is voltage of frequency input correct?
	Is operation mode setting correct?	<ul style="list-style-type: none"> • Operate operations through the digital panel.
Motor runs inversely	Are wiring for output terminals T1, T2, and T3 correct?	<ul style="list-style-type: none"> • Wiring must match U, V, and W terminals of the motor.
	Are wiring for forward and reverse signals correct?	<ul style="list-style-type: none"> • Check wiring are correct if necessary.
The motor speed can not be regulated.	Are wiring for analog frequency inputs correct?	<ul style="list-style-type: none"> • Check wiring are correct if necessary.
	Is the setting of operation mode correct?	<ul style="list-style-type: none"> • Check the operation mode of the operator.
	Is the load too heavy?	<ul style="list-style-type: none"> • Reduce the load.
Motor running speed too high or too low	Are specifications of the motor (poles, voltage...) correct?	<ul style="list-style-type: none"> • Confirm the motor's specifications.
	Is the gear ratio correct?	<ul style="list-style-type: none"> • Confirm the gear ratio.
	Is the setting of the highest output frequency correct?	<ul style="list-style-type: none"> • Confirm the highest output frequency.
Motor speed varies unusually	Is the load too heavy?	<ul style="list-style-type: none"> • Reduce the load.
	Does the load vary largely?	<ul style="list-style-type: none"> • Minimize the variation of the load. • Increase capacities of the inverter and the motor.
	Is the input power lack of phase?	<ul style="list-style-type: none"> • Add an AC reactor at the power input side if using single-phase power. • Check wiring if using three-phase power.

5.3 Quick troubleshooting of VAT200

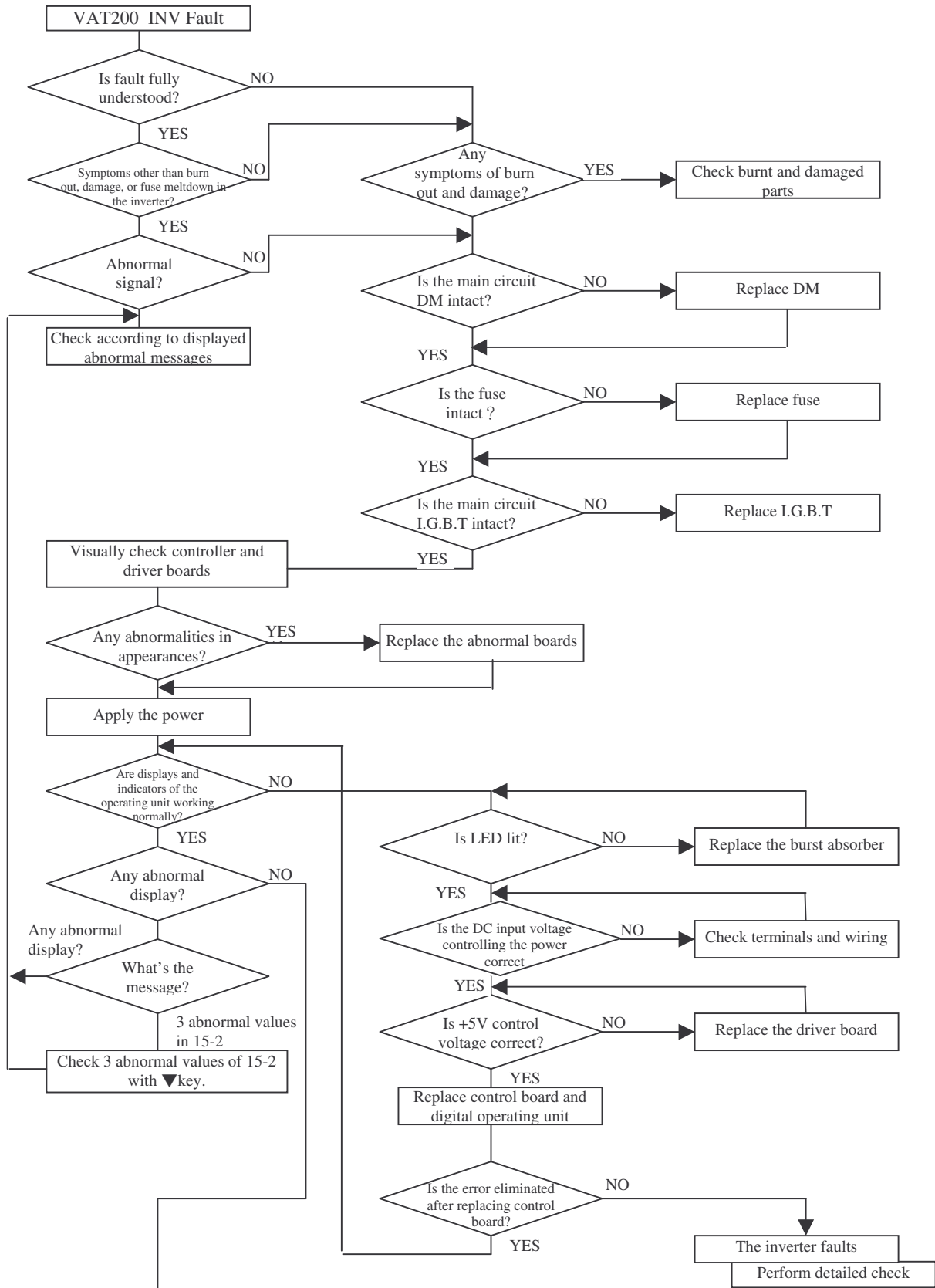

*to next page

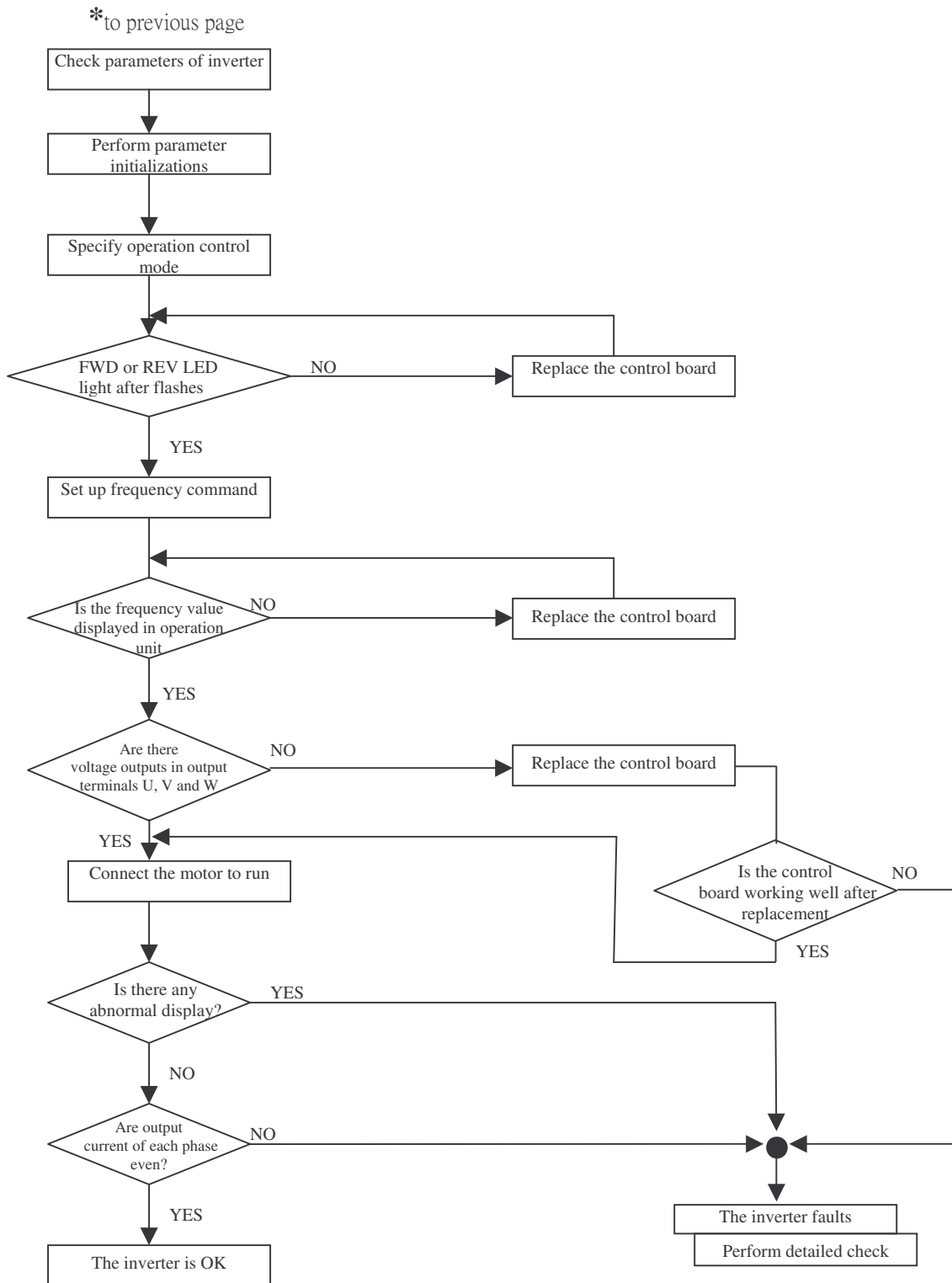

Troubleshooting for OC, OL error displays

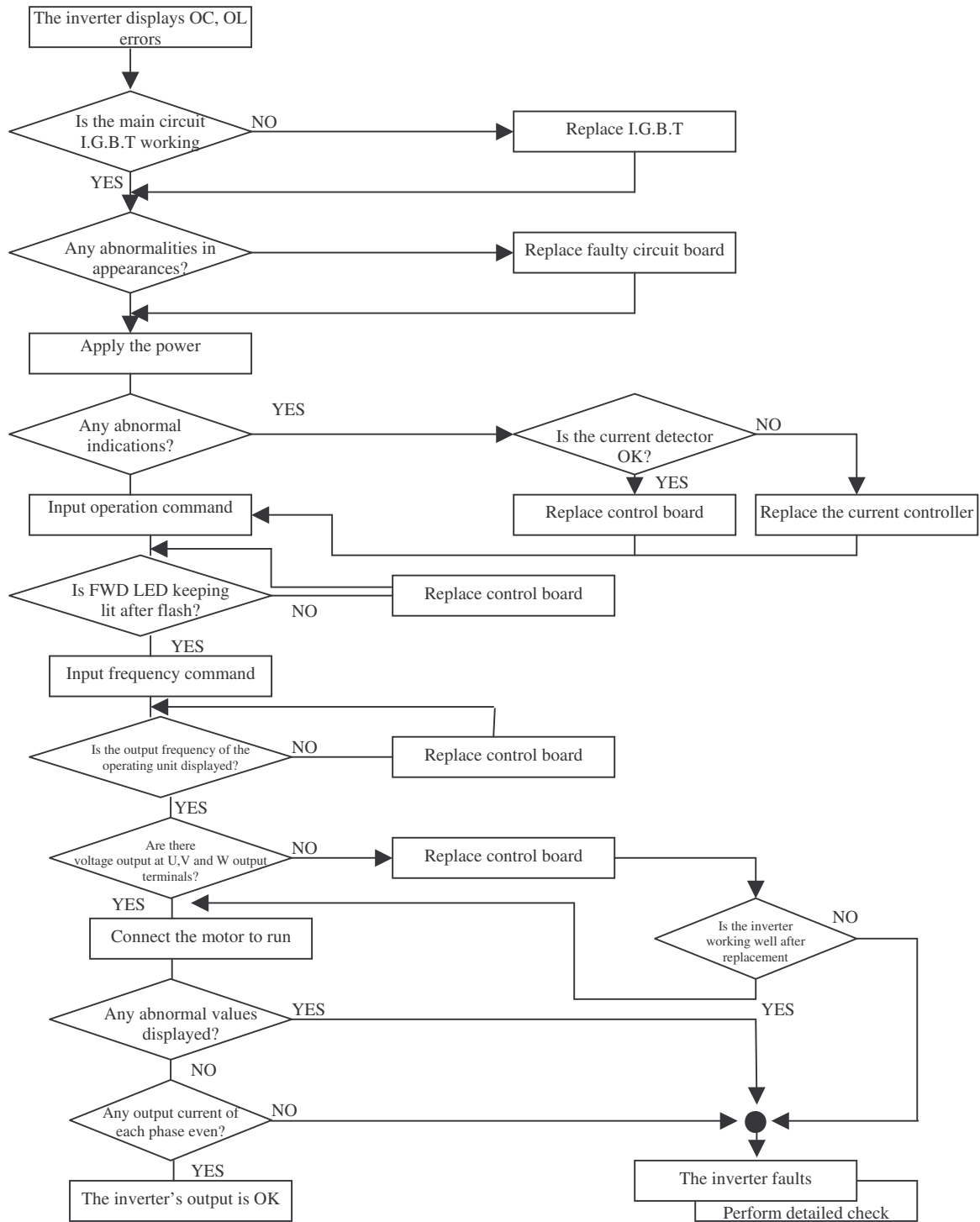

Troubleshooting for OV, LV error

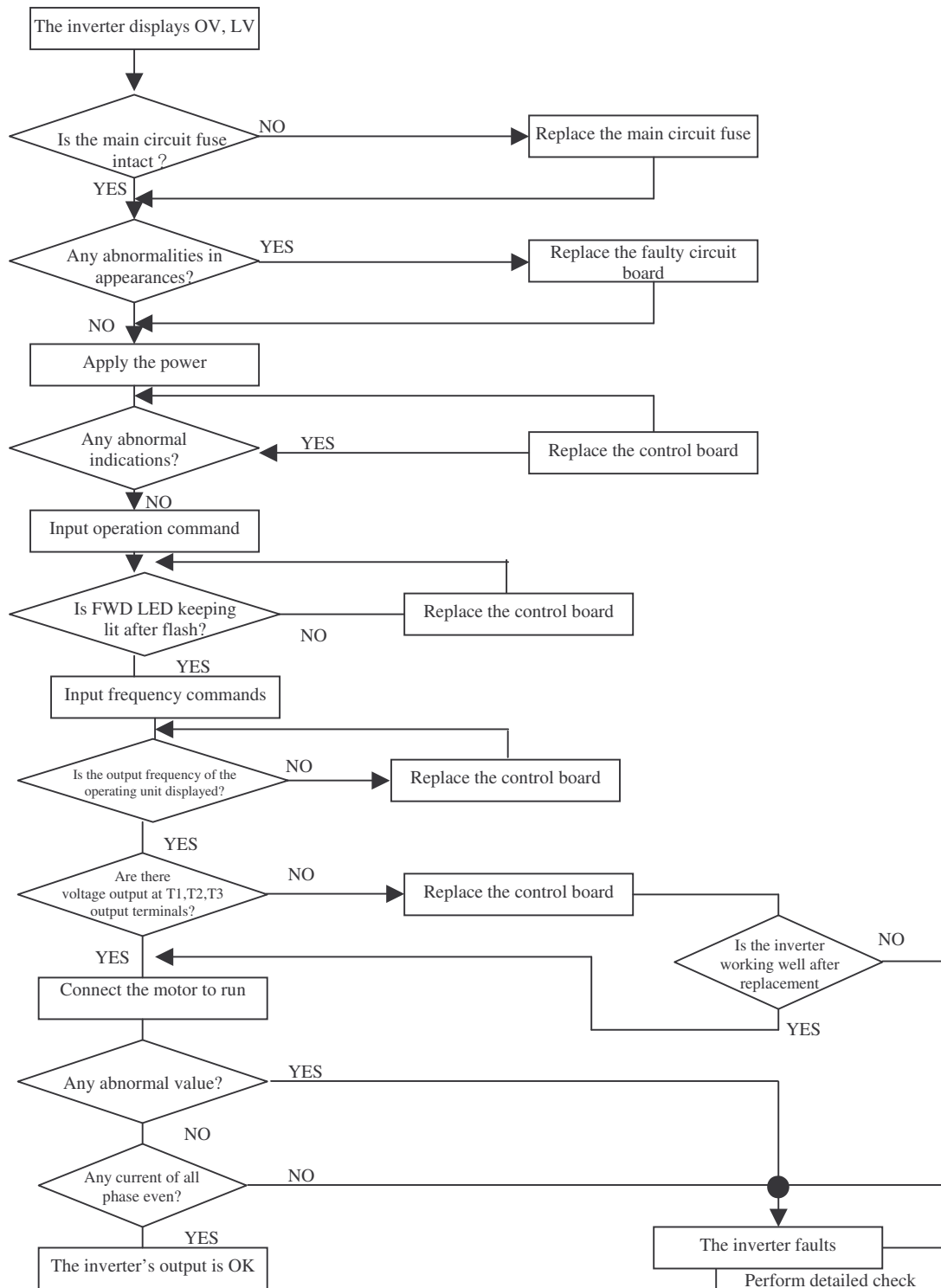

The motor can not run

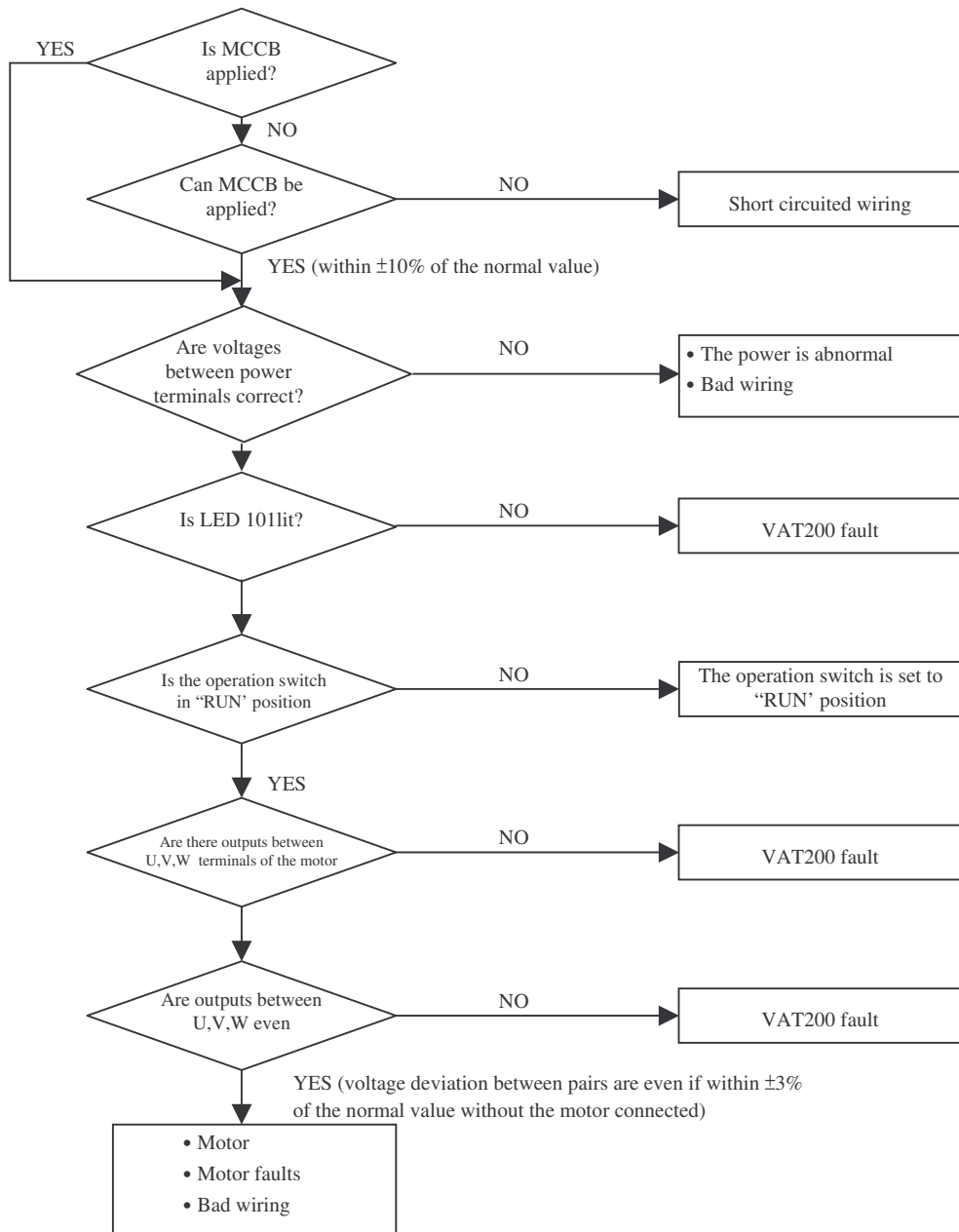

The motor is overheated

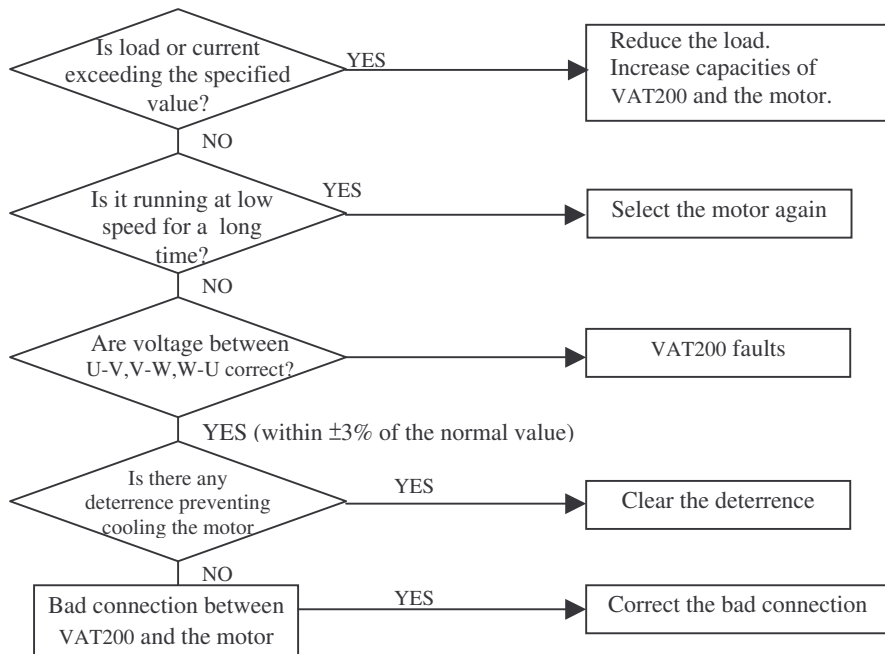

Motor runs unevenly

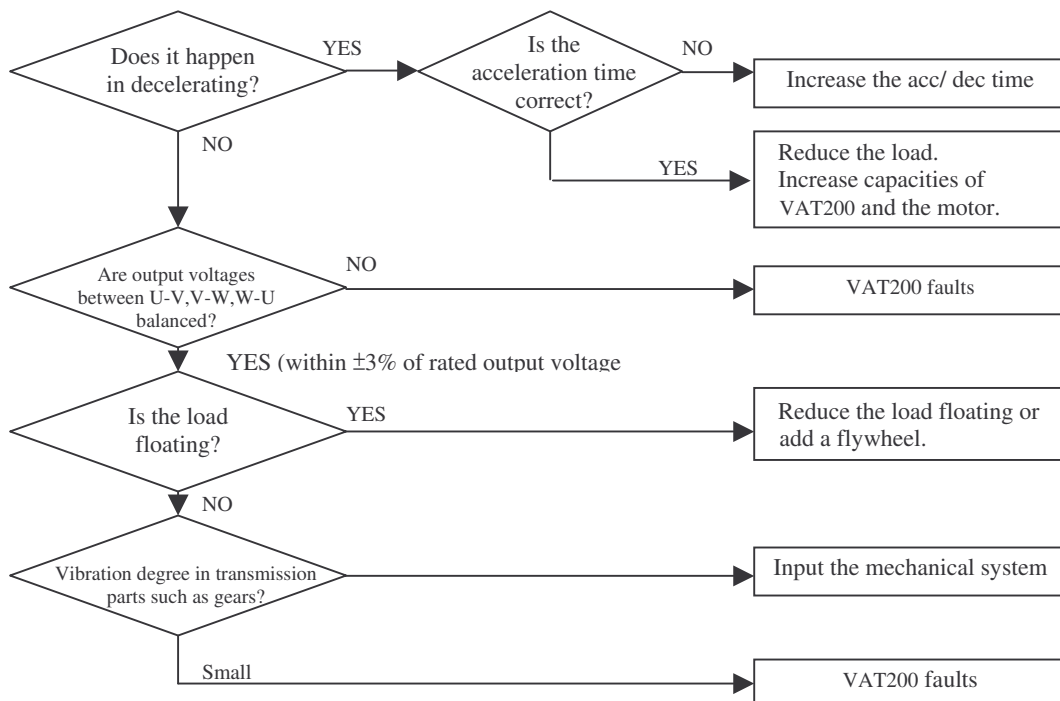

5.4 Routine inspection and period inspection

To ensure stable and safe operations, check and maintain the inverter regularly and periodically.

The table below lists the items to be check to ensure stable and safe operations.

Check these items 5 minutes after the “Charge” indicator goes out to prevent service persons from being hurt by residual electric power.

Items	Details	Checking period		Methods	Criteria	Remedies
		Daily	1Year			
Circumstances around the machine	Confirm the temperature and humidity around the machine	<input type="radio"/>		Measure with thermometer and hygrometer according to installation notices.	Temperature: -10 – 40°C Humidity: Below 95% RH	Improve the circumstances
	Are there inflammables piled up around?	<input type="radio"/>		Visual check	No foreign matters	
Installation and grounding of the inverter	Any unusual vibration from the machine	<input type="radio"/>		Visual, hearing	No foreign matters	Secure screws
	Is the grounding resistance correct?		<input type="radio"/>	Measure the resistance with a multi-tester	200V series: below 100Ω 400V series: below 10Ω	Improve the grounding
Input power voltage	Is the voltage of the main circuit correct?	<input type="radio"/>		Measure the voltage with a multi-tester	Voltage must conform with the specifications	Improve input voltage
External terminals and internal mounting screws of the inverter	Are secure parts loose?		<input type="radio"/>	Visual check Check with a screwdriver	No abnormalities	Secure or send back for repair
	Is the terminal base damaged?		<input type="radio"/>			
	Obvious rust stains		<input type="radio"/>			
Internal wiring of the inverter	Deformed or crooked		<input type="radio"/>	Visual check	No abnormalities	Replace or send back for repair
	Any damage of the wrapping of the conducting wire		<input type="radio"/>			
Heat sink	Heap of dust or mingled trifles	<input type="radio"/>		Visual check	No abnormalities	Clean up heaped dust
Printed circuit board	Heap of conductive metal or oil sludge		<input type="radio"/>	Visual check	No abnormalities	Clean up or replace the circuit board
	Discolored, overheated, or burned parts		<input type="radio"/>			
Cooling fan	Unusual vibration and noise		<input type="radio"/>	Visual or hearing check	No abnormalities	Replace the cooling fan
	Heap of dust or mingled trifles	<input type="radio"/>		Visual check		Clean up
Power component	Heap of dust or mingled trifles		<input type="radio"/>	Visual check	No abnormalities	Clean up
	Check resistance between each terminals		<input type="radio"/>	Measure with a multi-tester	No short circuit or broken circuit in three-phase output	Replace power component or inverter
Capacitor	Any unusual odor or leakage	<input type="radio"/>		Visual check	No abnormalities	Replace capacitor or inverter
	Any inflation or protrusion	<input type="radio"/>				

5.5 Maintenance and Inspection

Inverter doesn't need daily inspection and maintenance.

To ensure long-term reliability, follow the instructions below to perform regular inspection. Turn the power off and wait for the charge indicator (LED101) to go out before inspection to avoid potential shock hazard possibly caused by charges resides in high-capacity capacitors.

- (1) Clean up the accumulation of muck inside the inverter.
- (2) Check if there are any loose terminal screws and securing screws. Tighten all loose screws.
- (3) Insulation tests
 - (a) Disconnect all leads connecting VAT200 with external circuit when performing insulation tests against external circuit.
 - (b) Internal insulation test should be performed against the main circuit of the VAT200 body only. Use a high resistance DC 500V meter with insulating resistance higher than $5M\Omega$.

Caution! Do not perform this test against the control circuit.

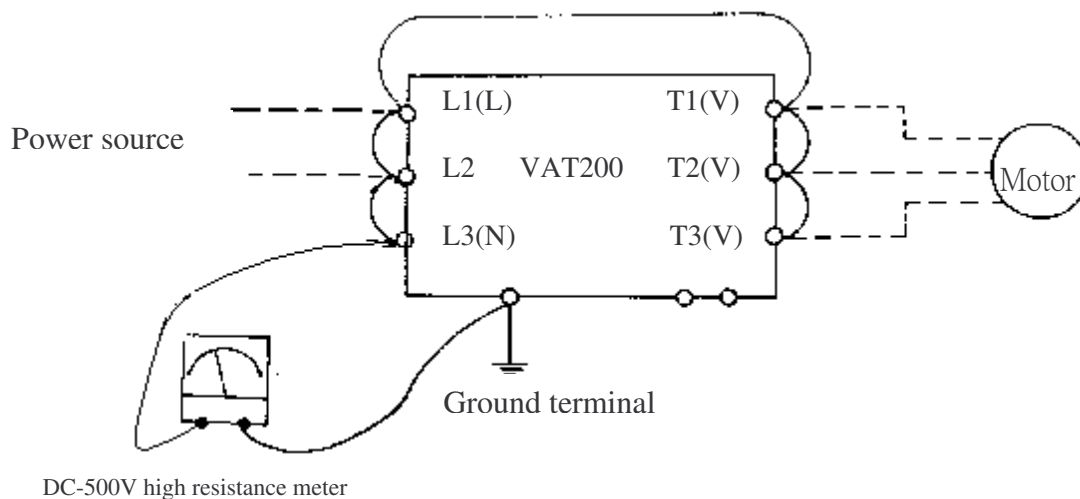

Chapter 6 Peripherals Components

6.1-6.2 Reactor specification at Input side and at DC Side

VAT200 Model	AC Input Reactor	DC Reactor	VAT200 Model	AC Input Reactor	DC Reactor
	Cat. Number	Cat. Number		Cat. Number	Cat. Number
U201N00K4	ACR8A2H5	DCR4A5H7	U203X00K7	ACR3A8H1	DCR3A15H2
U201N00K7	ACR12A2H5	DCR6A3H9	U203X01K5	ACR4A5H1	DCR4A9H2
U201N01K5	ACR18A1H3	DCR9A2H4	U203X02K2	ACR6A3H4	DCR6A6H8
U201N02K2	ACR22A0H84	DCR12A1H7	U203X04K0	ACR10A2H	DCR9A4H0
U203N00K4	ACR4A2H5	DCR4A5H7	U203X05K5	ACR14A1H4	DCR18A2H9
U203N00K7	ACR6A2H5	DCR6A3H9	U203X07K5	ACR18A1H1	DCR25A2H1
U203N01K5	ACR9A1H3	DCR9A2H4	U203X11K0	ACR27A0H75	DCR32A1H6
U203N02K2	ACR12A0H84	DCR12A1H7	U203X15K0	ACR35A0H58	-
U203N04K0	ACR18A0H56	DCR18A1H0	U203X18K5	ACR38A0H58	-
U203N05K5	ACR27A0H37	DCR32A0H78	U203X22K0	ACR45A0H45	-
U203N07K5	ACR35A0H27	DCR45A0H55	U203X30K0	ACR70A0H29	-
			U203X37K0	ACR90A0H22	-
			U203X45K0	ACR115A0H18	-
			U203X55K0	ACR160A0H14	-

6.3 Braking unit and braking resistor

VAT200 series braking current calculation

GE Drive	Motor KW	External Braking Unit (s)	GE Encapsulate Braking Resistor			GE Tubular Braking Resistor		
			CatNumber	ED%	Dim. (mm)	CatNumber	ED%	Dim. (mm)
U20_N00K4	0,4	-	ERN00K7	10	251*28*60	TLR200P200	10%	210*60*65
U20_N00K7	0,75	-	ERN00K7	10	251*28*60	TLR200P200	10%	210*60*65
U20_N01K5	1,5	-	ERN01K5	10	251*28*60	TLR100P200	10%	210*60*65
U20_N02K2	2,2	-	ERN02K2	10	274*34*78	TLR75P200	10%	210*60*65
U20_N04K0	4	-	ERN04K0	10	395*34*78	TLR44P600	10%	465*60*95
U20_N05K5	5,5	-	ERN05K5	10	400*40*100	TLR29P600	10%	465*60*95
U20_N07K5	7,5	-	ERN07K5	10	400*40*100	TLR22P600	10%	465*60*95
U203X00K7	0,75	-	ERX00K7	10	251*40*20	TLR750P200	10%	210*60*65
U203X01K5	1,5	-	ERX01K5	10	251*28*60	TLR400P200	10%	210*60*65
U203X02K2	2,2	-	ERX02K2	10	274*34*78	TLR240P200	10%	210*60*65
U203X04K0	4	-	ERX04K0	10	395*34*78	TLR175P600	10%	465*60*95
U203X05K5	5,5	-	ERX05K5	10	470*50*100	TLR118P600	10%	465*60*95
U203X07K5	7,5	-	ERX07K5	10	535*50*110	TLR86P600	10%	465*60*95
U203X11K0	11	-	-	-	-	TLR43P1000	10%	465*70*100
U203X15K0	15	-	-	-	-	TLR43P1000	10%	465*70*100
U203X18K5	18,5	U200ABU430	-	-	-	TLR35P1500	10%	460*140*100
U203X22K0	22	U200ABU430	-	-	-	TLR29P1800	10%	460*140*100
U203X30K0	30	U200ABU430	-	-	-	TLR22P2500	10%	460*140*180
U203X37K0	37	2x U200ABU430	-	-	-	2xTLR35P1500	10%	2x (460*140*100)
U203X45K0	45	2x U200ABU430	-	-	-	2xTLR29P1800	10%	2x (460*140*100)
U203X55K0	55	2 x U200ABU430	-	-	-	2xTLR22P2500	10%	2x (460*140*180)

- For Detailed information ask your supplier
- For drives 18.5KW and above, please add external Braking Unit: for 400V series: U200ABU430
- For drives 37KW and above need to use two Braking units. Each must be fitted with corresponding braking resistor

6.4 Digital operator and extension cable

A. Remote Cable Kit

Inverter Model	Extension Cable Kit	Cable Length (Meter)
All models	U200AW05	0.5
	U200AW10	1.0
	U200AW20	2.0
	U200AW30	3.0
	U200AW50	5.0

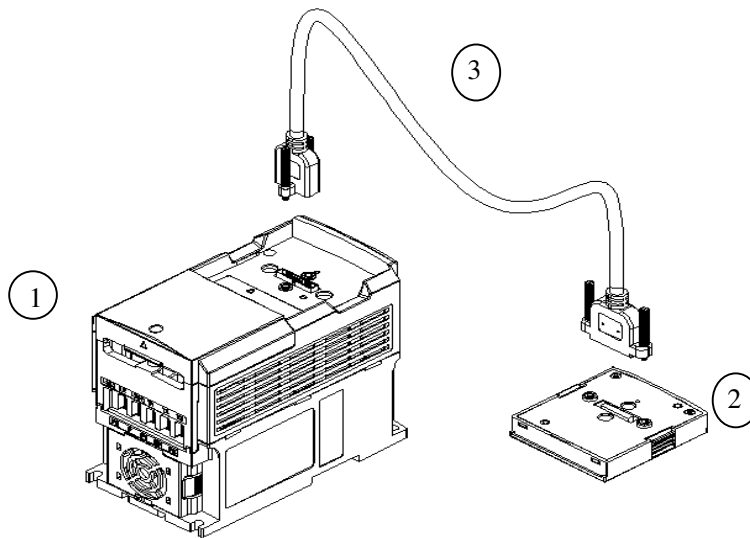

B. Content

- ① Inverter
- ② LED (U200ALEDK) or LCD (U200ALCDK) Keypad
- ③ REMOTE Cable for Keypad

C. Operation procedure:

Warning: Turn OFF the power supply. The following procedures should be performed after there is no display on the keypad.

1. Remove the keypad from the Inverter.
2. Please refer to Diagram before mounting the keypad to your machine or Panel.
3. Connect the inverter and the keypad with the remote cable in accordance with the above Diagram.

Supply the power to operate ONLY after all elements are securely fixed.

LED Keypad(U200ALEDK)Mounting Dimensions Unit : mm

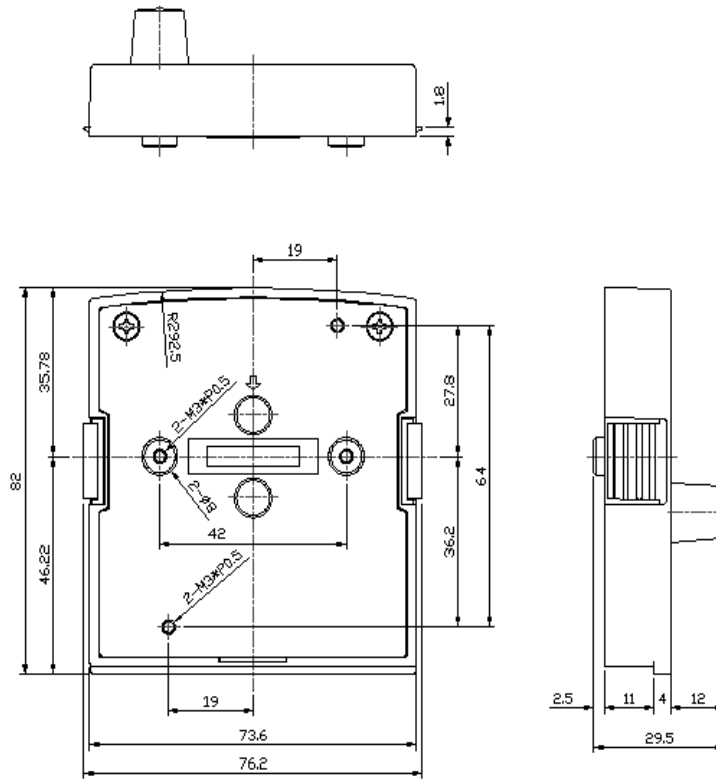

LCD Keypad(U200ALCDK)Mounting Dimensions Unit : mm

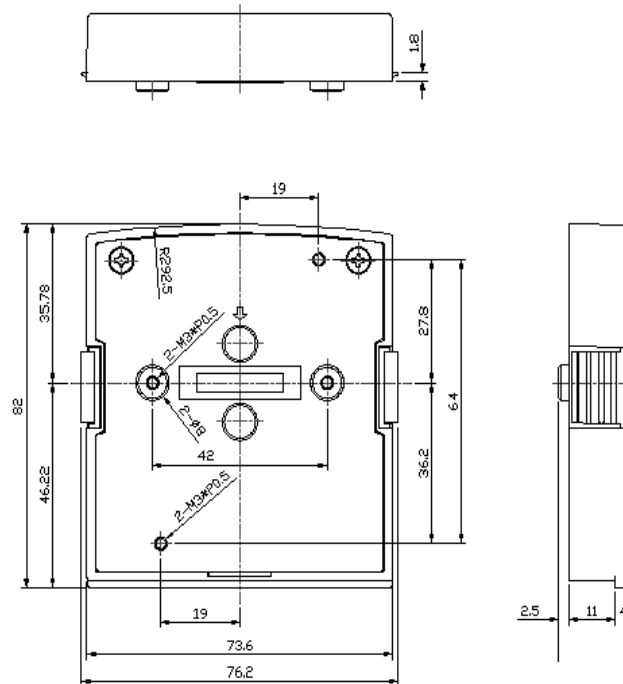

6.5 EMC Filter

The inverter adopts rapid switching components to improve the efficiency of the motor and to reduce the motor noise. Using the EMC Filter allows the EMI (Electromagnetic Interference) and RFI (Radio Frequency interference) to be controlled within certain range.

EMC Directives

The inverter with optional filter complies with the EMC directives 89/336/EEC, limiting the environmental EMI and RFI. Independent tests have demonstrated compliance to the following standards when the optional filters are used.

EMI radio standard、EMS immunity standard

EN 61800-3 1996/A11: 2000 : First Environment Unrestricted Distribution (Class B).

EN 61800-3 1996/A11: 2000 : First Environment Restricted Distribution

Filter Selection

Inverter Model	Rating (INPUT)	Filter Model	
		First Environment Restricted Distribution	First Environment Unrestricted Distribution
U201N00K4FS	1 φ 170 ~264V	Built in	U200F611TA1
U201N00K7FS	1 φ 170~264V	Built in	U200F611TA1
U201N01K5FS	1 φ 170~264V	Built in	U200F627TA2
U201N02K2FS	1 φ 170 ~264V	Built in	U200F627TA2
U201N00K4SS	1 φ 170 ~264V	U200F611TA1	--
U201N00K7SS	1 φ 170~264V	U200F611TA1	--
U201N01K5SS	1 φ 170~264V	U200F627TA2	--
U201N02K2SS	1 φ 170 ~264V	U200F627TA2	--
U203N00K4SS	3 φ 170 ~264V	U200F709TA1	--
U203N00K7SS	3 φ 170 ~264V	U200F709TA1	--
U203N01K5SS	3 φ 170 ~264V	U200F709TA1	--
U203N02K2SS	3 φ 170 ~264V	U200F719TA2	--
U203N04K0SS	3 φ 170 ~264V	U200F719TA2	--
U203N05K5SS	3 φ 170 ~264V	U200F739TA3	--
U203N07K5SS	3 φ 170 ~264V	U200F739TA3	--
U203X00K7FS	3 φ 323~528 V	Built in	U200F905TA1
U203X01K5FS	3 φ 323~528 V	Built in	U200F905TA1
U203X02K2FS	3 φ 323~528 V	Built in	U200F910TA2
U203X04K0FS	3 φ 323~528 V	Built in	U200F910TA2
U203X05K5FS	3 φ 323~528 V	Built in	U200F928TA3
U203X07K5FS	3 φ 323~528 V	Built in	U200F928TA3
U203X11K0FS	3 φ 323~528 V	Built in	U200F928TA3
U203X00K7SS	3 φ 323~528 V	U200F905TA1	--
U203X01K5SS	3 φ 323~528 V	U200F905TA1	--
U203X02K2SS	3 φ 323~528 V	U200F910TA2	--
U203X04K0SS	3 φ 323~528 V	U200F910TA2	--
U203X05K5SS	3 φ 323~528 V	U200F928TA3	--
U203X07K5SS	3 φ 323~528 V	U200F928TA3	--
U203X11K0SS	3 φ 323~528 V	U200F928TA3	--
U203X15K0SS	3 φ 323~528 V	U200F34048S-MA	--
U203X18K5SS	3 φ 323~528 V	U200F370A	--
U203X22K0SS	3 φ 323~528 V	U200F370A	--
U203X30K0SS	3 φ 323~528 V	U200F3100A	--
U203X37K0SS	3 φ 323~528 V	U200F3100A	--
U203X45K0SS	3 φ 323~528 V	U200F3150A	--
U203X55K0SS	3 φ 323~528 V	U200F3180A	--

VAT200 External Filter Size

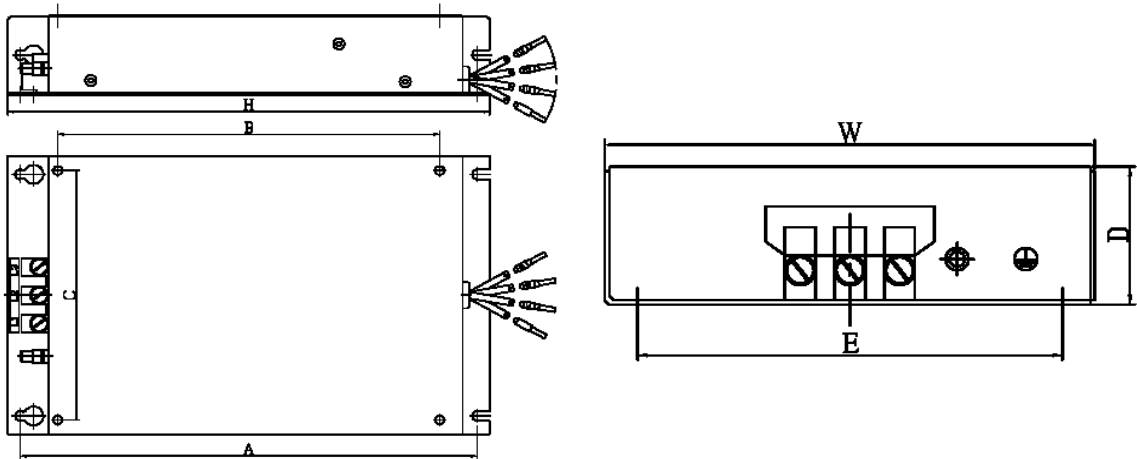

MODEL \ SIZE	Inverter Mounting Dimensions (C*B)	External Filter Size (W*H*D)	External Filter Mounting Dimensions(E*A)
U200F611TA1 U200F709TA1 U200F905TA1	78 * 150	91 * 192 * 28	74 * 181
U200F627TA2 U200F719TA2 U200F910TA2	114.6 * 170.5	128 * 215 * 37	111 * 204
U200F739TA3 U200F928TA3	173 * 244	188 * 289 * 42	165 * 278

Model	Dimensions (mm)						
	W	W1	H	H1	D	d	M
U200F370A	93	79	312	298	190	7	M6
U200F3100A	93	79	312	298	190	7	M6
U200F3150A	126	112	312	298	224	7	M6
U200F3180A	126	112	312	298	224	7	M6

U200F34048S-MA :

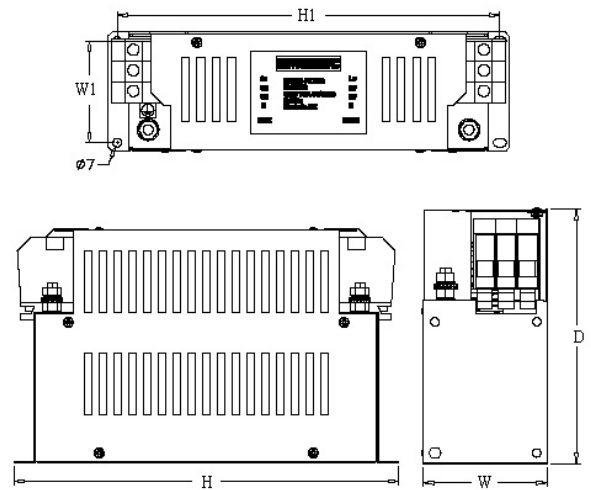
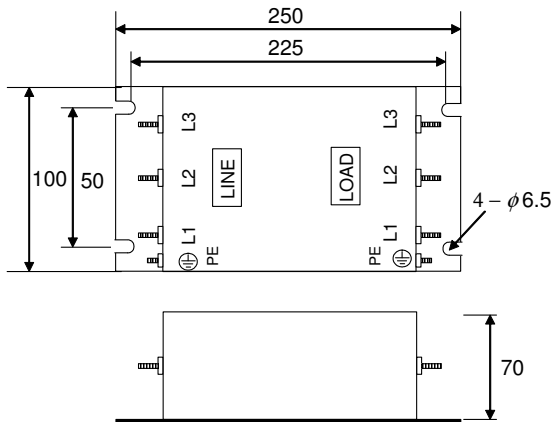

6.6 Interface Card

6.6.1 RS-485 Interface Card (Model : U200ARS-485)

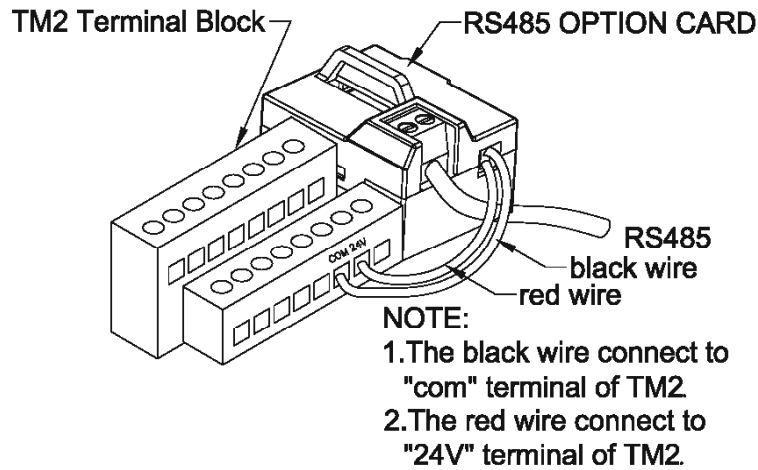

U200ARS-485 Wiring Diagram:

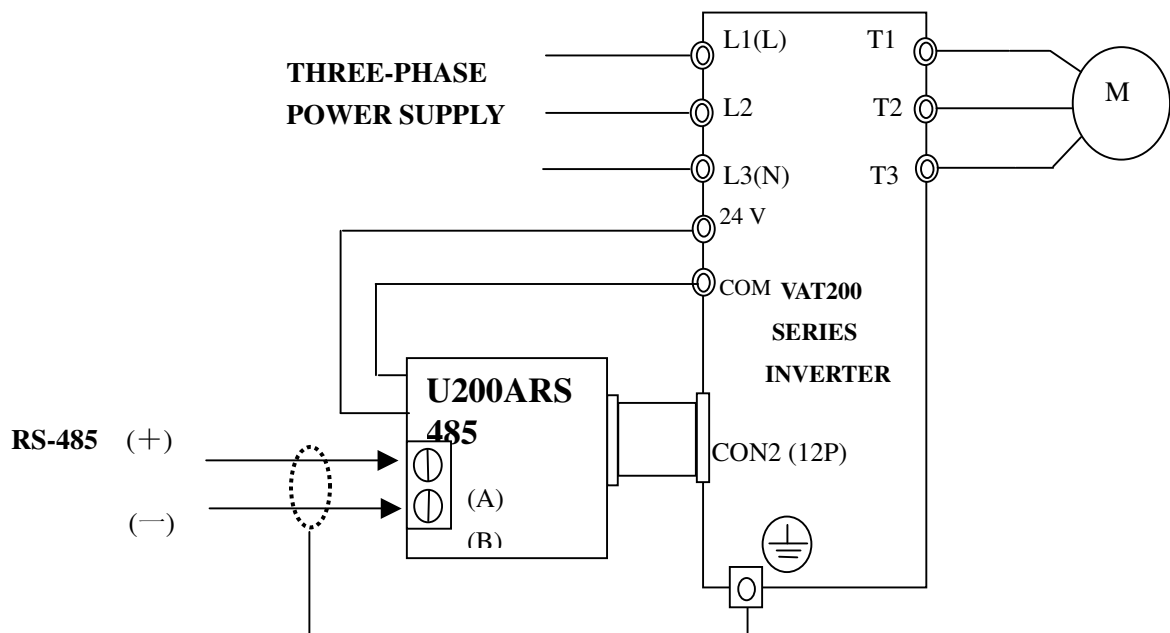

※**Note:**

Please put on the cover of inverter to avoid the Interface Card disturbed by outside static electricity.

Please using isolated RS232 / RS485 converter to link PC and interface card to avoid damage equipment.

6.6.2 RS-232 Interface Card (Model : U200ARS-232)

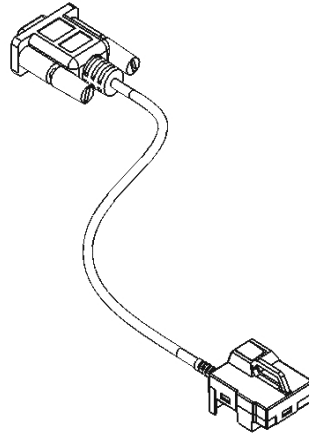

U200ARS-232Wiring Diagram:

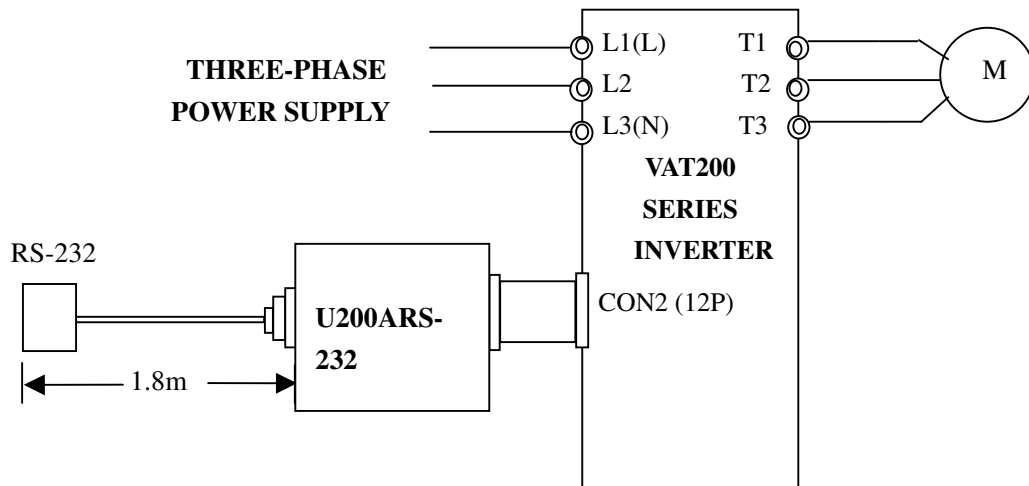

6.6.3 Program Copy Unit (Model: U200AMP)

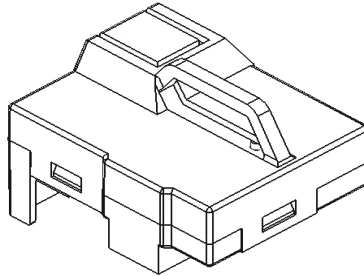

U200AMP Wiring Diagram

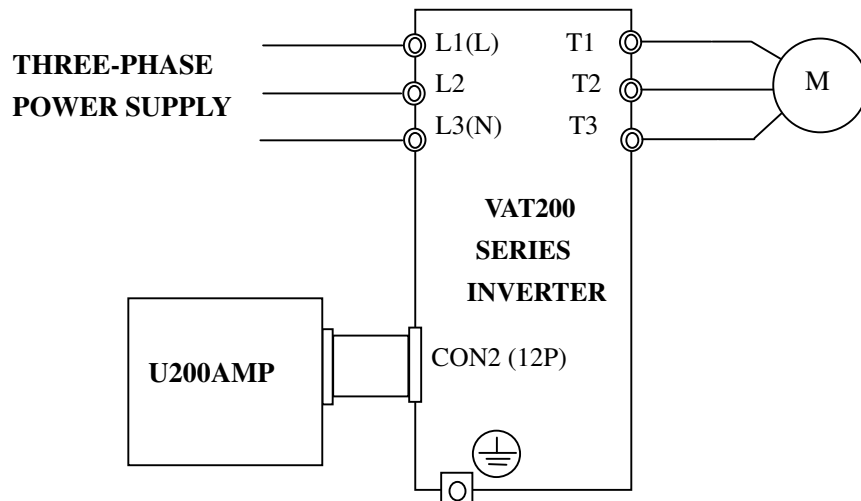

6.6.4 PDA Link

- ①. HP iPAQ Pocket PC h2210. (PDA)
- ②. PDA wire (U200ARSPDA).
- ③. RS-232 Interface Card (U200ARS232).
- ④. Inverter

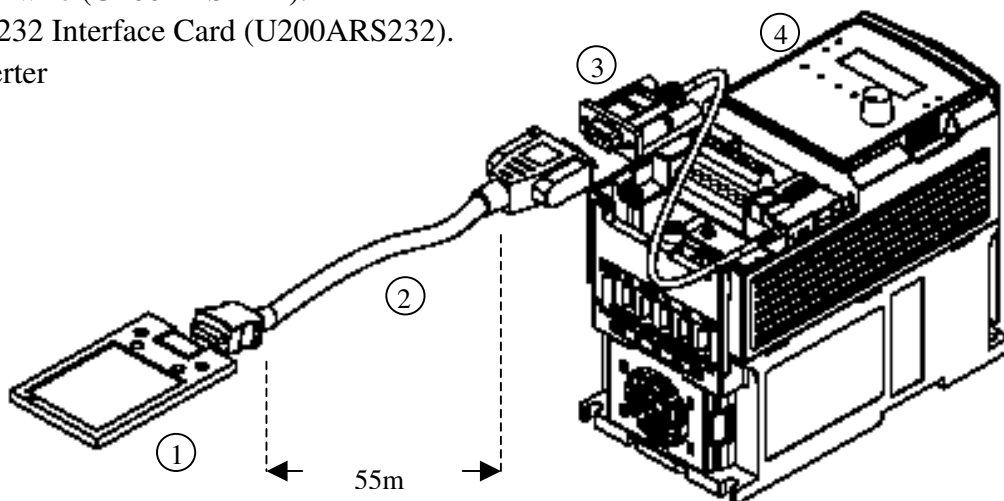

Appendix 1: VAT200 Motor Internal Parameter List

Factory Setting of the Motor Internal Parameters :

Parameter Model	14-0 (stator Resistance)	14-1 (Rotor Resistance)	14-2 (Equivalent Inductance)	14-3 (Magnetization Current)	14-4 (iron Loss Conductance)		
U20_ N00K4	200	200	800	7200	0		
U20_ N00K7 U20_ X00K7	380	300					
U20_ N01K5 U20_ X01K5	300	280					
U20_ N02K2 U20_ X 02K2	280	240					
U20_ N04K0 U20_ X 04K0	260	200					
U20_ N05K5 U20_ X 05K5	240	160					
U20_ N07K5 U20_ X07K5	220	150					
U20_ X11K0	200	140					
U20_ X15K0 U20_ X18K5 U20_ X22K0 U20_ X30K0 U20_ X37K0 U20_ X45K0 U20_ X55K0	180	130				4100	205

※Note :

1. The above motor internal parameters are idle under V/F Control Mode. These parameters are usable under vector control mode.
2. The motor parameters (14-0~14-4) are not be modified when factory setting under vector mode. The internal parameters will be maintained at the ones after auto tuning (refer to Auto Tuning and Description on motor Internal Parameter).
- 3: The motor parameters (14-0~14-4) will be modified to factory setting completely under whatever operation mode.

Appendix 2: VAT200 parameter setting list

Customer				Inverter Model			
Using Site				Contact Phone			
Address							
Parameter Code	Setting Content	Parameter Code	Setting Content	Parameter Code	Setting Content	Parameter Code	Setting Content
0-00		3-14		6-06		10-7	
0-01		3-15		6-07		10-8	
0-02		3-16		6-08		10-9	
0-03		3-17		7-00		11-0	
0-04		3-18		7-01		11-1	
0-05		3-19		7-02		11-2	
0-06		3-20		7-03		11-3	
0-07		3-21		7-04		11-4	
0-08		3-22		7-05		11-5	
1-00		3-23		8-00		11-6	
1-01		3-24		8-01		11-7	
1-02		3-25		8-02		12-0	
1-03		3-26		8-03		12-1	
1-04		3-27		8-04		12-2	
1-05		3-28		8-05		12-3	
1-06		3-29		9-00		12-4	
1-07		4-00		9-01		12-5	
2-00		4-01		9-02		12-6	
2-01		4-02		9-03		13-0	
2-02		4-03		9-04		13-1	
2-03		4-04		9-05		13-2	
2-04		4-05		9-06		13-3	
2-05		5-00		9-07		13-4	
2-06		5-01		9-08		14-0	
3-00		5-02		9-09		14-1	
3-01		5-03		9-10		14-2	
3-02		5-04		9-11		14-3	
3-03		5-05		9-12		14-4	
3-04		5-06		9-13		15-0	
3-05		5-07		9-14		15-1	
3-06		5-08		9-15		15-2	
3-07		5-09		10-0		15-3	
3-08		6-00		10-1		15-4	
3-09		6-01		10-2		15-5	
3-10		6-02		10-3		15-6	
3-11		6-03		10-4			
3-12		6-04		10-5			
3-13		6-05		10-6			

GE POWER CONTROLS
Hornhouse Lane
Knowsley Industrial Park
Liverpool L33 7YQ

GE POWER CONTROLS IBERICA
Marqués de Comillas 1
E-08225 Terrassa

GE CONSUMER & INDUSTRIAL GmbH
Sachsenring 83
D-50677 Köln

GE POWER CONTROLS FRANCE
7, Rue Nicolas Robert BP32
ZI La Garenne
F-93601 Aulnay sous Bois Cédex

GE POWER CONTROLS ITALIA
Via Tortona 35
I-20144 Milano

GE POWER CONTROLS BELGIUM
Nieuwevaart 51
B-9000 Gent



GE imagination at work